

# EPSON

## **Industrial Robot: SCARA Robots LS-C series Manual**

Original instructions

© Seiko Epson Corporation 2024-2026

Rev.3  
ENM263R8423F

# Table of Contents

- 1. FOREWORD ..... 10**
- 1.1 Introduction ..... 11
- 1.2 Trademarks ..... 11
- 1.3 Terms of Use ..... 11
- 1.4 Manufacturer ..... 11
- 1.5 Contact Information ..... 11
- 1.6 Disposal ..... 12
- 1.7 Before Reading this Manual ..... 12
  - 1.7.1 Structure of the Control System ..... 12
  - 1.7.2 Turning ON/OFF Controller ..... 12
  - 1.7.3 Shape of Motors ..... 12
  - 1.7.4 Setting by Using Software ..... 12
  - 1.7.5 Figures in this Manual ..... 13
  - 1.7.6 Pictures in this Manual ..... 13
- 1.8 The Manuals of This Product ..... 13
- 2. LS4-C, LS8-C Manipulator ..... 15**
- 2.1 Safety ..... 16
  - 2.1.1 Conventions ..... 16
  - 2.1.2 Design and Installation Safety ..... 16
    - 2.1.2.1 Strength of the Ball Screw Spline ..... 17
  - 2.1.3 Operation Safety ..... 18
  - 2.1.4 Emergency Stop ..... 19
  - 2.1.5 Safeguard ..... 20
  - 2.1.6 Emergency Movement without Drive Power ..... 21
  - 2.1.7 ACCELS Setting for CP Motions ..... 22
  - 2.1.8 Warning Labels ..... 23
  - 2.1.9 Response for Emergency or Malfunction ..... 25
    - 2.1.9.1 Collision ..... 25
    - 2.1.9.2 Getting body caught in Manipulator ..... 25
- 2.2 Specification ..... 27
  - 2.2.1 Model number ..... 27

---

2.2.2 Part Names and Outer Dimensions .....	28
2.2.2.1 LS4-C .....	28
2.2.2.2 LS8-C .....	33
2.2.3 Specification table .....	39
2.2.4 How to Set the Model .....	39
2.3 Environment and Installation .....	39
2.3.1 Environment .....	39
2.3.2 Base Table .....	41
2.3.3 Mounting Dimensions .....	42
2.3.4 Unpacking and Transportation .....	43
2.3.5 Installation Procedure .....	44
2.3.5.1 Standard Environment Specification .....	44
2.3.5.2 Cleanroom Environment Specification .....	45
2.3.6 Connecting the Cables .....	46
2.3.7 Installed wire for customer use .....	48
2.3.8 Relocation and Storage .....	50
2.3.8.1 Precautions for Relocation and Storage .....	50
2.3.8.2 Relocation .....	52
2.4 Setting of End Effectors .....	54
2.4.1 Attaching and End Effector .....	54
2.4.2 Attaching Cameras and Valves .....	56
2.4.3 Weight and Inertia Settings .....	57
2.4.3.1 Weight Setting .....	57
2.4.3.2 Load on the Shaft .....	58
2.4.3.3 Load on the Arm .....	58
2.4.3.4 Automatic speed setting by Weight .....	59
2.4.3.5 Automatic acceleration/deceleration setting by Weight .....	61
2.4.3.6 Inertia Setting .....	63
2.4.3.7 Moment of Inertia and the Inertia Setting .....	64
2.4.3.8 Moment of inertia of load on the shaft .....	64
2.4.3.9 Automatic acceleration/deceleration setting of Joint #4 by Inertia (moment of inertia) .....	64
2.4.3.10 Eccentric Quantity and the Inertia Setting .....	67
2.4.3.11 Eccentric quantity of load on the shaft .....	67
2.4.3.12 Automatic acceleration/deceleration setting by Inertia (eccentric quantity) .....	67
2.4.3.13 Calculating the Moment of Inertia .....	73

---

2.4.4 Precautions for Auto Acceleration/Deceleration of Joint #3 .....	74
2.4.4.1 Automatic acceleration/deceleration vs. Joint #3 position .....	74
2.5 Motion Range .....	80
2.5.1 Motion Range Setting by Pulse Range .....	81
2.5.1.1 Max. Pulse Range of Joint #1 .....	81
2.5.1.2 Max. Pulse Range of Joint #2 .....	82
2.5.1.3 Max. Pulse Range of Joint #3 .....	83
2.5.1.4 Max. Pulse Range of Joint #4 .....	83
2.5.2 Motion Range Setting by Mechanical Stops .....	84
2.5.2.1 Setting the Mechanical Stops of Joints #1 and #2 .....	84
2.5.2.2 Setting the Mechanical Stops of Joints #3 .....	86
2.5.3 Setting the Cartesian (Rectangular) Range in the XY Coordinate System of the Manipulator .....	88
2.5.4 Standard Motion Range .....	89
<b>3. LS20-C Manipulator .....</b>	<b>93</b>
3.1 Safety .....	94
3.1.1 Conventions .....	94
3.1.2 Design and Installation Safety .....	94
3.1.2.1 Strength of the Ball Screw Spline .....	95
3.1.3 Operation Safety .....	96
3.1.4 Emergency Stop .....	97
3.1.5 Safeguard .....	98
3.1.6 Emergency Movement without Drive Power .....	99
3.1.7 ACCELS Setting for CP Motions .....	100
3.1.8 Warning Labels .....	101
3.1.9 Response for Emergency or Malfunction .....	102
3.1.9.1 Collision .....	102
3.1.9.2 Getting body caught in Manipulator .....	102
3.2 Specification .....	104
3.2.1 Model number .....	104
3.2.2 Part Names and Outer Dimensions .....	104
3.2.2.1 Standard environment specification (LS20-C**4S) .....	105
3.2.2.2 Cleanroom Standard Environment Specification (LS20-C**4C) .....	108
3.2.3 Specification table .....	110
3.2.4 How to Set the Model .....	110

3.3 Environment and Installation .....	110
3.3.1 Environment .....	110
3.3.2 Base Table .....	112
3.3.3 Mounting Dimensions .....	113
3.3.4 Unpacking and Transportation .....	114
3.3.5 Installation Procedure .....	117
3.3.5.1 Standard environment specification .....	117
3.3.5.2 Cleanroom Environment Specification .....	118
3.3.6 Connecting the Cables .....	118
3.3.6.1 Method to Connect the Manipulator and M/C Cable .....	119
3.3.6.2 Connecting M/C Cables and Controller .....	120
3.3.7 Installed wire for customer use .....	121
3.3.8 Relocation and Storage .....	123
3.3.8.1 Precautions for Relocation and Storage .....	123
3.3.8.2 Relocation .....	125
3.4 Setting of End Effectors .....	127
3.4.1 Attaching and End Effector .....	127
3.4.2 Attaching Cameras and Valves .....	128
3.4.3 Weight and Inertia Settings .....	129
3.4.3.1 Weight Setting .....	129
3.4.3.2 Load on the Shaft .....	130
3.4.3.3 Load on the Arm .....	130
3.4.3.4 Automatic speed setting by Weight .....	131
3.4.3.5 Automatic acceleration/deceleration setting by Weight .....	132
3.4.3.6 Inertia Setting .....	132
3.4.3.6.1 Moment of Inertia and the Inertia Setting .....	132
3.4.3.6.2 Moment of inertia of load on the shaft .....	133
3.4.3.6.3 Automatic acceleration/deceleration setting of Joint #4 by Inertia (moment of inertia) .....	133
3.4.3.6.4 Eccentric Quantity and the Inertia Setting .....	133
3.4.3.6.5 Eccentric quantity of load on the shaft .....	134
3.4.3.6.6 Automatic acceleration/deceleration setting by Inertia (eccentric quantity) .....	134
3.4.3.6.7 Calculating the Moment of Inertia .....	135
3.4.3.6.8 Moment of Inertia and the Inertia Setting .....	136
3.4.3.6.9 Moment of inertia of load on the shaft .....	137
3.4.3.6.10 Automatic acceleration/deceleration setting of Joint #4 by Inertia (moment of inertia) .....	

3.4.3.6.11 Eccentric Quantity and the Inertia Setting .....	137
3.4.3.6.12 Eccentric quantity of load on the shaft .....	138
3.4.3.6.13 Automatic acceleration/deceleration setting by Inertia (eccentric quantity) .....	138
3.4.3.6.14 Calculating the Moment of Inertia .....	139
3.4.3.7 Moment of Inertia and the Inertia Setting .....	140
3.4.3.8 Moment of inertia of load on the shaft .....	141
3.4.3.9 Eccentric quantity of load on the shaft .....	141
3.4.4 Precautions for Auto Acceleration/Deceleration of Joint #3 .....	141
3.4.4.1 Automatic acceleration/deceleration vs. Joint #3 position .....	142
3.5 Motion Range .....	142
3.5.1 Motion Range Setting by Pulse Range .....	143
3.5.1.1 Max. Pulse Range of Joint #1 .....	143
3.5.1.2 Max. Pulse Range of Joint #2 .....	144
3.5.1.3 Max. Pulse Range of Joint #3 .....	144
3.5.1.4 Max. Pulse Range of Joint #4 .....	145
3.5.2 Motion Range Setting by Mechanical Stops .....	145
3.5.2.1 Setting the Mechanical Stops of Joints #1 and #2 .....	146
3.5.3 Setting the Cartesian (Rectangular) Range in the XY Coordinate System of the .....	148
3.5.4 Standard Motion Range .....	148
<b>4. LS50-C Manipulator .....</b>	<b>151</b>
4.1 Safety .....	152
4.1.1 Conventions .....	152
4.1.2 Design and Installation Safety .....	152
4.1.2.1 Strength of the Ball Screw Spline .....	153
4.1.3 Operation Safety .....	154
4.1.4 Emergency Stop .....	155
4.1.5 Safeguard .....	156
4.1.6 Emergency Movement without Drive Power .....	157
4.1.7 ACCELS Setting for CP Motions .....	158
4.1.8 Warning Labels .....	159
4.1.9 Response for Emergency or Malfunction .....	160
4.1.9.1 Collision .....	160
4.1.9.2 Getting body caught in Manipulator .....	160
4.2 Specification .....	161
4.2.1 Model number .....	161

---

4.2.2 Part Names and Outer Dimensions .....	162
4.2.3 Specification table .....	165
4.2.4 How to Set the Model .....	165
4.3 Environment and Installation .....	165
4.3.1 Environment .....	165
4.3.2 Base Table .....	167
4.3.3 Mounting Dimensions .....	168
4.3.4 Unpacking and Transportation .....	169
4.3.5 Installation Procedure .....	171
4.3.6 Connecting the Cables .....	174
4.3.6.1 Method to Connect the Manipulator and M/C Cable .....	174
4.3.6.2 Connecting M/C Cables and Controller .....	175
4.3.7 Installed wire for customer use .....	176
4.3.7.1 Electrical Wires .....	176
4.3.7.2 Pneumatic Tubes .....	177
4.3.8 Relocation and Storage .....	178
4.3.8.1 Precautions for Relocation and Storage .....	178
4.3.8.2 Relocation .....	180
4.4 Setting of End Effectors .....	181
4.4.1 Attaching and End Effector .....	181
4.4.2 Attaching Cameras and Valves .....	182
4.4.3 Weight and Inertia Settings .....	183
4.4.3.1 Weight Setting .....	184
4.4.3.2 Load on the Shaft .....	184
4.4.3.3 Load on the Arm .....	184
4.4.3.4 Automatic speed setting by Weight .....	185
4.4.3.5 Automatic acceleration/deceleration setting by Weight .....	186
4.4.3.6 Inertia Setting .....	186
4.4.3.6.1 Moment of Inertia and the Inertia Setting .....	187
4.4.3.6.2 Moment of inertia of load on the shaft .....	187
4.4.3.6.3 Automatic acceleration/deceleration setting of Joint #4 by Inertia (moment of inertia) .....	187
4.4.3.6.4 Eccentric Quantity and the Inertia Setting .....	188
4.4.3.6.5 Eccentric quantity of load on the shaft .....	188
4.4.3.6.6 Automatic acceleration/deceleration setting by Inertia (eccentric quantity) .....	189
4.4.3.6.7 Calculating the Moment of Inertia .....	189

---

4.4.4 Precautions for Auto Acceleration/Deceleration of Joint #3 ..... 191

    4.4.4.1 Automatic acceleration/deceleration vs. Joint #3 position ..... 191

4.5 Motion Range ..... 191

    4.5.1 Motion Range Setting by Pulse Range ..... 192

        4.5.1.1 Max. Pulse Range of Joint #1 ..... 192

        4.5.1.2 Max. Pulse Range of Joint #2 ..... 193

        4.5.1.3 Max. Pulse Range of Joint #3 ..... 193

        4.5.1.4 Max. Pulse Range of Joint #4 ..... 194

    4.5.2 Motion Range Setting by Mechanical Stops ..... 194

        4.5.2.1 Setting the Mechanical Stops of Joints #1 ..... 195

        4.5.2.2 Setting the Mechanical Stops of Joints #3 ..... 197

    4.5.3 Setting the Cartesian (Rectangular) Range in the XY Coordinate System of the ..... 199

    4.5.4 Standard Motion Range ..... 199

**5. Daily Inspection ..... 201**

    5.1 Daily Inspection of LS4-C and LS8-C Manipulator ..... 202

        5.1.1 Inspection ..... 202

            5.1.1.1 Schedule for Inspection ..... 202

            5.1.1.2 Inspection point ..... 203

        5.1.2 Overhaul (Parts Replacement) ..... 204

        5.1.3 Greasing ..... 204

        5.1.4 Tightening the hexagon socket head cap bolt ..... 207

    5.2 Daily Inspection of LS20-C Manipulator ..... 209

        5.2.1 Inspection ..... 209

            5.2.1.1 Schedule for Inspection ..... 209

            5.2.1.2 Inspection point ..... 210

        5.2.2 Overhaul (Parts Replacement) ..... 211

        5.2.3 Greasing ..... 211

        5.2.4 Tightening the hexagon socket head cap bolt ..... 214

    5.3 Daily Inspection of LS50-C Manipulator ..... 216

        5.3.1 Inspection ..... 216

            5.3.1.1 Schedule for Inspection ..... 216

            5.3.1.2 Inspection point ..... 217

        5.3.2 Overhaul (Parts Replacement) ..... 218

        5.3.3 Greasing ..... 218

        5.3.4 Tightening the hexagon socket head cap bolt ..... 221

<b>6. Appendix</b> .....	<b>223</b>
6.1 Appendix A: Included Items .....	224
6.1.1 LS4-C Included Items .....	224
6.1.2 LS8-C Included Items .....	224
6.1.3 LS20-C Included Items .....	224
6.1.4 LS50-C Included Items .....	224
6.2 Appendix B: Specification Table .....	225
6.2.1 LS4-C Specification Table .....	225
6.2.2 LS8-C Specification Table .....	229
6.2.3 LS20-C Specification Table .....	233
6.2.4 LS50-C Specification Table .....	237
6.3 Appendix C: Stopping time and Stopping distance in Emergency .....	241
6.3.1 Stopping Time and Stopping Distance in Emergency .....	243
6.3.2 LS8-C Stopping Time and Stopping Distance in Emergency .....	246
6.3.3 LS20-C Stopping Time and Stopping Distance in Emergency .....	255
6.3.4 LS50-C Stopping Time and Stopping Distance in Emergency .....	257
6.3.5 Supplementary Information on Stopping time and Stopping distance during an Emergency Stop .....	258
6.3.5.1 How to check the stopping time and stopping distance in the customer's environment .....	258
6.3.5.2 Introduction of commands that are useful in measuring the stopping time and stopping distance .....	259
6.4 Appendix D: Stopping time and Stopping distance when Safeguard is Opened .....	260
6.4.1 LS4-C Stopping Time and Stopping Distance when Safeguard is Opened .....	262
6.4.2 LS8-C Stopping Time and Stopping Distance when Safeguard is Opened .....	265
6.4.3 Stopping Time and Stopping Distance when Safeguard is Opened .....	274
6.4.4 LS50-C Stopping Time and Stopping Distance when Safeguard is Opened .....	276
6.4.5 Supplementary Information of the Stopping Time and Stopping Distance When Safeguard is Open .....	277
6.4.5.1 How to check the stopping time and stopping distance in the customer's environment .....	277
6.4.5.2 Introduction of commands that are useful in measuring the stopping time and stopping distance .....	278

# 1. FOREWORD

## 1.1 Introduction

Thank you for purchasing this Epson robot system. This manual provides the information necessary for correctly using the robot system.

Before using the system, please read this manual and related manuals to ensure correct use.

After reading this manual, store it in an easily accessible location for future reference.

Epson conducts rigorous testing and inspection to ensure that the performance of our robot systems meets our standards. Please note that if the Epson robot system is used outside the operating conditions described in the manual, the product will not perform up to its basic performance.

This manual describes potential hazards and problems that are foreseen. To use the Epson robot system safely and correctly, be sure to follow the safety information contained in this manual.

## 1.2 Trademarks

Microsoft, Windows, and the Windows logo are either registered trademarks or trademarks of Microsoft Corporation in the United States and/or other countries. All other company names, brand names, and product names are registered trademarks or trademarks of their respective companies.

## 1.3 Terms of Use

No part of this instruction manual may be reproduced or reprinted in any form without express written permission.

The information in this document is subject to change without notice.

Please contact us if you find any errors in this document or if you have any questions about the information in this document.

## 1.4 Manufacturer

**SEIKO EPSON CORPORATION**

## 1.5 Contact Information

Contact information details are listed in the "Supplier" section in the following manual.

Note that the contact information may vary depending on your region.

"Safety Manual - Contact Information"

The Safety Manual is also available at the following site.

URL: <https://download.epson.biz/robots/>



## 1.6 Disposal

When disposing of this product, please do so in accordance with the laws and regulations of your country.

## 1.7 Before Reading this Manual

This section describes what you should know before reading this manual.

### 1.7.1 Structure of the Control System

The LS-C series Manipulator is made up of a combination of the following Controller and software.

#### LS4-C series

- Controller: RC800-A
- Software: Epson RC+ 8.0 or later

#### LS8-C series

- Controller: RC800-A
- Software: Epson RC+ 8.0 or later

#### LS20-C series

- Controller: RC800-A
- Software: Epson RC+ 8.0 or later

#### LS50-C series

- Controller: RC800-A
- Software: Epson RC+ 8.0 or later

### 1.7.2 Turning ON/OFF Controller

When you see the instruction “Turn ON/OFF the Controller” in this manual, be sure to turn ON/OFF all the hardware components.

For the Controller composition, refer to the following.

#### Structure of the Control System

### 1.7.3 Shape of Motors

The shape of the motors used for the Manipulator that you are using may be different from the shape of the motors described in this manual because of the specifications.

### 1.7.4 Setting by Using Software

This manual contains setting procedures using the software. They are indicated by the following symbol.

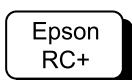

## 1.7.5 Figures in this Manual

The figures of Manipulators indicated in this manual are Standard-model Manipulators. Unless special instruction is provided, the specifications of Standard-model and Cleanroom-model are the same.

## 1.7.6 Pictures in this Manual

Pictures and illustrations of the Manipulator in this manual may differ from the Manipulator you are using depending on the shipment date and the specifications.

## 1.8 The Manuals of This Product

The following are typical manual types for this product and an outline of the descriptions.

### “Safety Manual”

This manual contains safety information for all people who handle this product. The manual also describes the process from unpacking to operation and the manual you should look at next.

Read this manual first.

- Safety precautions regarding robot system and residual risk
- Declaration of conformity
- Training
- Flow from unpacking to operation

### RC800 series Manual

This manual explains the installation of the entire robot system and the specifications and functions of the controller. The manual is primarily intended for people who design robot systems.

- The installation procedure of the robot system (specific details from unpacking to operation)
- Daily inspection of the controller
- Controller specifications and basic functions

### LS-C series Manual (This book)

This manual describes the specifications and functions of the Manipulator. The manual is primarily intended for people who design robot systems.

- Technical information, functions, specifications, etc. required for the Manipulator installation and design
- Daily inspection of the Manipulator

### Status Code/Error Code List

This manual contains a list of code numbers displayed on the controller and messages displayed in the software message area. The manual is primarily intended for people who design robot systems or do programming.

### RC800 series Service Manual

### LS-C series Service Manual

This manual describes the details of maintenance etc. It is intended for people who perform maintenance.

- Daily inspection
- Replacement and repair of maintenance parts

- The method of firmware update and controller setting backup etc.

### **Epson RC+ 8.0 User's Guide**

This manual describes general information about program development software.

### **Epson RC+ 8.0 SPEL+ Language Reference**

This manual describes the robot programming language "SPEL+".

### **Other Manual**

Manuals for each option are available.

## **2. LS4-C, LS8-C Manipulator**

This volume contains information for setup and operation of the Manipulators.

Please read this volume thoroughly before setting up and operating the Manipulators.

## 2.1 Safety

The Manipulator and its related equipment should be unpacked and transported by people who have received installation training provided by Epson and the suppliers. Also, the laws and regulations of the installation country must be followed.

Before use, please read this manual and other related manuals to ensure correct use. After reading this manual, store it in an easily accessible location for future reference.

This product is intended for transporting and assembling parts in a safely isolated area.

### 2.1.1 Conventions

The following symbols are used in this manual to indicate important safety information. Be sure to read the descriptions shown with each symbol.

#### WARNING

This symbol indicates an imminently hazardous situation which, if operation is not performed properly, will result in death or serious injury.

#### WARNING

This symbol indicates a potentially hazardous situation which, if operation is not performed properly, could result in an injury due to electric shock.

#### CAUTION

This symbol indicates a potentially hazardous situation which, if operation is not performed properly, may result in a minor or moderate injury or in property damage only.

### 2.1.2 Design and Installation Safety

This product is intended for transporting and assembling parts in a safely isolated area.

Design and installation of robot system shall be performed by personnel who has taken robot system training held by us and suppliers.

To ensure safety, a safeguard must be installed for the robot system. For details on the safeguard, refer to the following.

#### Safeguard

The following items are safety precautions for design personnel.

#### WARNING

- Personnel who design and/or construct the robot system with this product must read the “Safety Manual” to understand the safety requirements before designing and/or constructing the robot system. Designing and/or constructing the robot system without understanding the safety requirements is extremely hazardous, may

result in serious bodily injury and/or severe equipment damage to the robot system, and may cause serious safety problems.

- The Manipulator and the Controller must be used within the environmental conditions described in their respective manuals. This product has been designed and manufactured strictly for use in a normal indoor environment. Using the product in an environment that exceeds the specified environmental conditions may not only shorten the life cycle of the product but may also cause serious safety problems.
- The robot system must be used within the installation requirements described in the manuals. Using the robot system outside of the installation requirements may not only shorten the life cycle of the product but also cause serious safety problems.
- When designing or installing a robot system, wear at least the following protective gear. Working without protective gear may cause serious safety problems.
  - Work clothes suitable for work
  - Helmet
  - Safety shoes

Further precautions for installation are mentioned in the following.

**Environment and Installation**

Please read this chapter carefully to understand safe installation procedures before installing the robots and robotic equipment.

**2.1.2.1 Strength of the Ball Screw Spline**

If a load exceeding the allowable value is applied to the ball screw spline, it may not work properly due to deformation or breakage of the shaft.

If the ball screw spline is applied the load exceeding the allowable value, it is necessary to replace the ball screw spline unit. The allowable loads differ depending on distance where the load is applied to. For calculating the allowable load, see the calculation formula below.

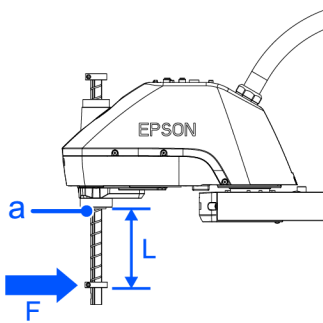

Symbol	Description
a	End of the spline nut

**Example:**

If 100 N (10.2kgf) load is applied at 100 mm from the end of the spline nut

**Allowable bending moment**

LS4-C:M=13,000 N·mm

LS8-C:M=27,000 N·mm

**Moment**

$$M=F \cdot L = 100 \cdot 100 = 10,000 \text{ N} \cdot \text{mm}$$

## 2.1.3 Operation Safety

The following items are safety precautions for qualified Operator personnel:

### WARNING

- Please carefully read the Safety Requirements in the “Safety Manual” before operating the robot system. Operating the robot system without understanding the safety requirements is extremely hazardous and may result in serious bodily injury and/or severe equipment damage to the robot system.
- Do not enter the operating area of the Manipulator while the power to the robot system is turned ON. Entering the operating area with the power ON is extremely hazardous and may cause serious safety problems as the Manipulator may move even if it seems to be stopped.
- Before operating the robot system, make sure that no one is inside the safeguarded area. The robot system can be operated in the mode for teaching even when someone is inside the safeguarded area. The motion of the Manipulator is always in restricted (low speed and low power) status to secure the safety of an operator. However, operating the robot system while someone is inside the safeguarded area is extremely hazardous and may result in serious safety problems in case that the Manipulator moves unexpectedly.
- Immediately press the Emergency Stop switch whenever the Manipulator moves abnormally while the robot system is operated.

### WARNING

- To shut off power to the robot system, disconnect the power plug from the power source or use a disconnecter. Be sure to connect the AC power cable to either a power receptacle or a disconnecter. DO NOT connect it directly to a factory power source.
- Before performing any replacement procedure, turn OFF the Controller and related equipment, and then disconnect the power plug from the power source. Performing any replacement procedure with the power ON is extremely hazardous and may result in electric shock and/or malfunction of the robot system.
- Do not connect or disconnect the motor connectors while the power to the robot system is turned ON. Connecting or disconnecting the motor connectors with the power ON is extremely hazardous and may result in serious bodily injury as the Manipulator may move abnormally. Performing any work procedure with the power turned on is extremely dangerous and may result in electric shock and/or malfunction of the robot system.

### CAUTION

- Whenever possible, only one person should operate the robot system. If it is necessary to operate the robot system with more than one person, ensure that all people involved communicate with each other as to what they are doing and take all necessary safety precautions.
- Joint #1, #2, and #4: If the joints are operated repeatedly with the operating angle less than 5 degrees, the bearings are likely to cause oil film shortage in such situation. Repeating the operation may cause the Manipulator to break faster. To prevent early breakdown, move each joint larger than 50 degrees for about once an hour.
- Joint #3: If the up-and-down motion of the hand is less than 32 mm for LS4-C and 40 mm for LS8-C, move the joint a half of the maximum stroke for about once an hour.

- Vibration (resonance) may occur continuously in low speed Manipulator motion (Speed: approx. 5 to 20%) depending on combination of Arm orientation and end effector load. Vibration arises from natural vibration frequency of the Arm and can be controlled by following measures.
  - Changing Manipulator speed
  - Changing the teach points
  - Changing the end effector load

## 2.1.4 Emergency Stop

Each robot system needs equipment that will allow the operator to immediately stop the system's operation. Install an emergency stop device by using emergency stop input from the Controller or other equipment.

Before using the emergency stop switch, be aware of the following points.

- The emergency stop switch should be used to stop the Manipulator only in case of emergencies.
- Besides pressing the emergency stop switch when an emergency occurs, to stop the Manipulator during program operation, use the Pause or STOP (program stop) statements assigned to a standard I/O.  
The Pause and STOP statements do not turn off motor energization, and so the brake is not locked.

To place the robot system in emergency stop mode in a non-emergency (normal) situation, press the emergency stop switch while the Manipulator is not operating.

Do not press the emergency stop switch unnecessarily while the Manipulator is operating normally.

It could shorten the lifespan of the following components.

- Brakes  
The brakes will be locked, which will shorten the lifespan of the brakes due to worn brake friction plates.
  - Normal brake lifespan:  
About 2 years (when the brakes are used 100 times/day)  
or about 20,000 times
- Reduction gears  
An emergency stop applies an impact to the reduction gear, which can shorten its life.

If the Manipulator is stopped by turning off the Controller while it is operating, the following problems may occur.

- Reduced life and damage to reduction gear
- Position shift at the joints

If a power outage or other unavoidable Controller power-off occurs during Manipulator operation, check the following points after power is restored.

- Damage in reduction gear
- Shifting of the joints from their proper positions

If there was any shifting, maintenance is required. For more information, please contact the supplier.

### Stopping distance of emergency stop

The Manipulator during operation cannot stop immediately after the emergency stop switch is pressed. Also, the stopping time and movement distance vary depending on the following factors.

- Hand weight, WEIGHT setting, ACCEL setting, workpiece weight, SPEED setting, movement posture, etc.

For the stopping time and movement distance of the Manipulator, refer to the following section.

## Appendix C: Stopping time and Stopping distance in Emergency

### 2.1.5 Safeguard

To maintain a safe working zone, safety barriers must be set up around the Manipulator, and safeguards must be installed at the entrance and exit of the safety barriers.

The term "safeguard" as used in this manual refers to a safety device with an interlock that allows entry into the safety barriers. Specifically, this includes safety door switches, safety barriers, light curtains, safety gates, safety floor mats, and so on. The safeguard is an input that informs the Robot Controller that an operator may be inside the safeguard area. You must assign at least one Safeguard (SG) in Safety Function Manager.

When the safeguard is opened, Protective Stop operates to change to the safeguard open state (display: SO).

- Safeguard open  
Operations are prohibited. Further robot operation is not possible until either the safeguard is closed, the latched state is released, and a command is executed, or the TEACH or TEST operation mode is turned on and the enable circuit is activated.
- Safeguard closed  
The robot can operate automatically in an unrestricted (high power) state.

#### WARNING

- If a third party accidentally releases the safeguard while an operator is working inside the safety barriers, this may result in a hazardous situation. To protect the operator working inside the safety barriers, implement measures to lock out or tag out the latch release switch.
- To protect operators working near the robot, be sure to connect a safeguard switch and make sure that it works properly.

#### Installing safety barriers

When installing safety barriers within the maximum range of the Manipulator, combine safety functions such as SLP. Carefully take into account the size of the hand and the workpieces to be held so that no interference occurs between the operating parts and the safety barriers.

#### Installing safeguards

Design the safeguards so that they satisfy the following requirements:

- When using a key switch type safety device, use a switch that forcibly opens the interlock contacts. Do not use switches that open their contacts using the spring force of the interlock.
- When using an interlock mechanism, do not disable the interlock mechanism.

#### Considering the stopping distance

During operation, the Manipulator cannot stop immediately even if the safeguard is opened. Also, the stopping time and movement distance vary depending on the following factors.

- Hand weight, WEIGHT setting, ACCEL setting, workpiece weight, SPEED setting, movement posture, etc.

For the stopping time and movement distance of the Manipulator, refer to the following section.

## Appendix D: Stopping time and Stopping distance when Safeguard is Opened

### Precautions for safeguard operation

Do not open the safeguard unnecessarily while the motor is energized. Frequent safeguard inputs will reduce the life of the relay.

- Normal relay lifespan: Approximately 20,000 times

## 2.1.6 Emergency Movement without Drive Power

When the system is placed in emergency mode, push the arm or joint of the Manipulator by hand as shown below:

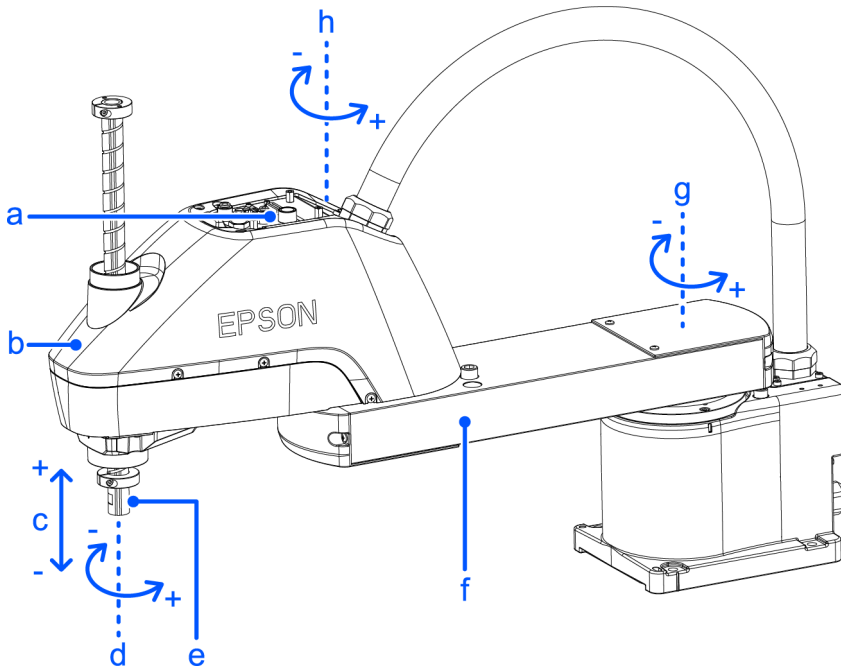

(Figure: LS8-C602S)

Symbol	Description
a	Joint #3 #4 Brake release switch
b	Arm #2
c	Joint #3 (up and down)
d	Joint #4 (rotating)
e	Shaft
f	Arm #1
g	Joint #1 (rotating)
h	Joint #2 (rotating)

- Arm #1: Push the arm by hand.
- Arm #2: Push the arm by hand.
- Joint #3: The joint cannot be moved up/down manually because the electromagnetic brake applied to the joint is operating. Move the joint up/down while pressing the brake release switch.
- Joint #4: The shaft cannot be rotated manually because the electromagnetic brake applied to the shaft is operating. Move the joint up/down while pressing the brake release switch.

### KEY POINTS

The brake release switch affects both Joints #3 and #4. When the brake release switch is pressed in emergency mode, the brake for both Joints #3 and #4 are released simultaneously. Be careful of the shaft falling and rotating due to hand weight while the brake release switch is being pressed.

## 2.1.7 ACCELS Setting for CP Motions

To make the Manipulator move in a CP motion, make the appropriate ACCELS settings in the SPEL program based on the tip load and Z-axis height.

### KEY POINTS

If the ACCELS settings are not properly configured, the following problem occurs.

- Shortened lifespan and damage to the ball screw spline
- Stop with error (Error code: 4002)

Set ACCELS as shown below based on the Z-axis height.

### Maximum ACCELS correction values by Z-axis height and tip load

#### LS4-C

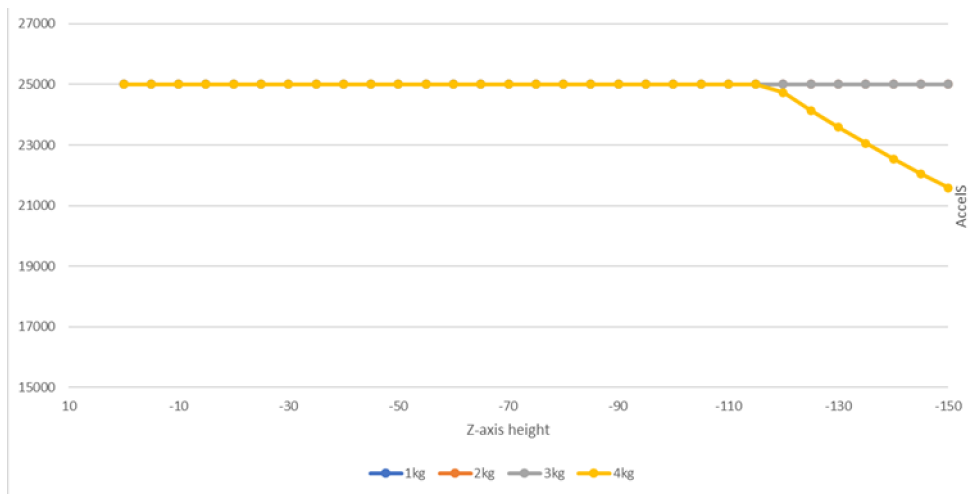

#### LS8-C

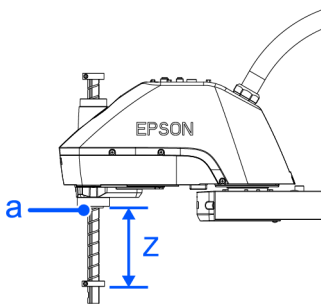
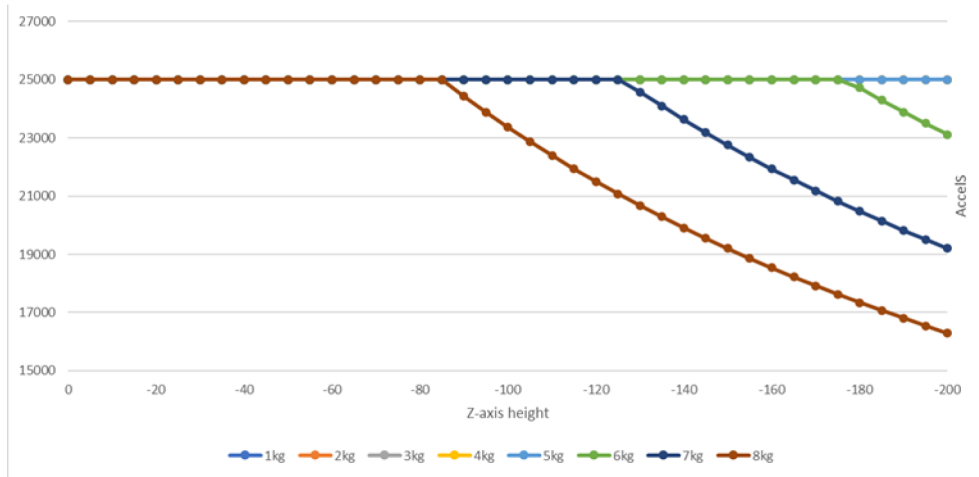

Symbol	Description
a	Z-axis height 0 (Origin position)

If the Manipulator is operated in CP motion with the wrong set values, make sure to check the following.

- Whether or not the ball screw spline shaft is deformed or bent

### 2.1.8 Warning Labels

The Manipulator has the following warning labels. Specific hazards exist in the vicinity of areas with the warning labels. Be thoroughly careful in handling. To ensure that the Manipulator is operated and maintained safely, be sure to follow the safety information and warnings indicated on the warning labels. Also, do not tear, damage, or remove these warning labels.

A



Touching any internal electrified parts while the power is turned on may cause electric shock.

**B**



The surface of the Manipulator is very hot during and after operation which can cause for you to get burnt.

**1**

This indicates the product name, model name, serial number, information of supported laws and regulations, product specifications, manufacturer, importer, date of manufacture, country of manufacture, and the like.

For details, see the label affixed to the product.

**2**



Indicates the position of the brake release switch

Indicates the position of a threaded hole for an eye bolt mounting screw.

**LS4-C**

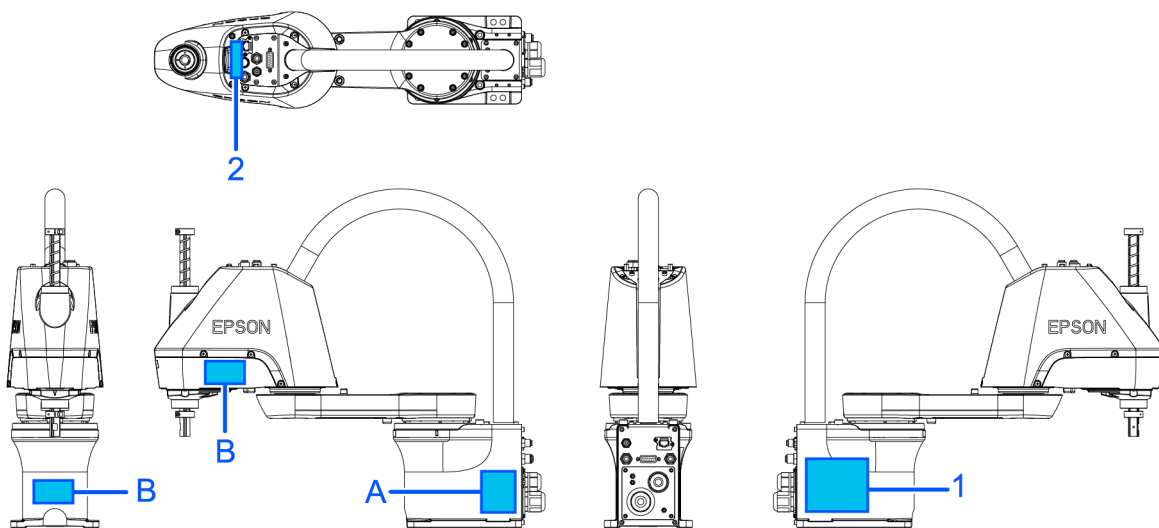

**LS8-C**

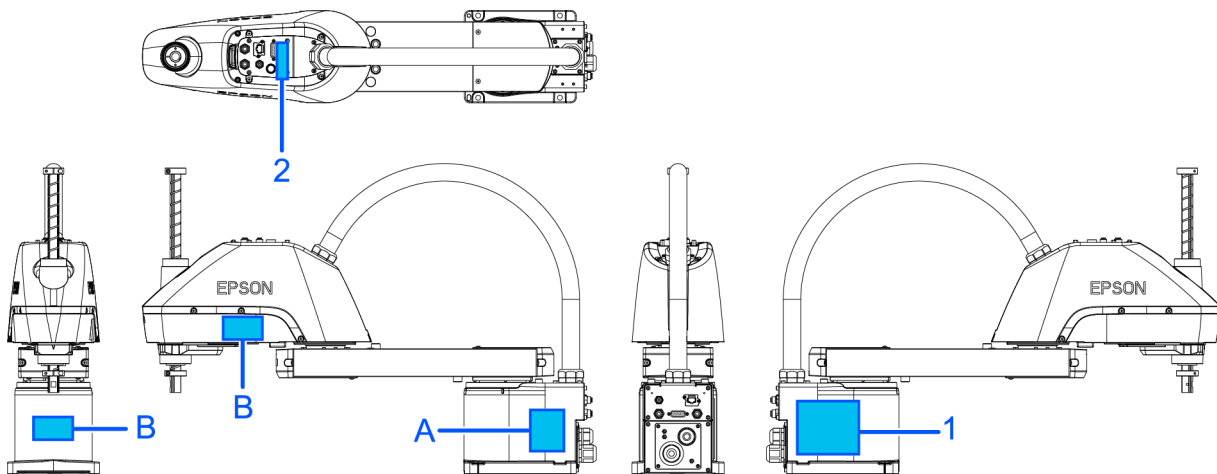

## 2.1.9 Response for Emergency or Malfunction

### 2.1.9.1 Collision

If the Manipulator has collided with a mechanical stop, peripheral device, or other object, discontinue use and contact the supplier.

Also, if the Manipulator collides with mechanical stops or peripheral devices, the following problems may occur.

- Reduction of the life and damage of the reduction gear unit
- Position gap at the joints

### 2.1.9.2 Getting body caught in Manipulator

When the operator is caught between the Manipulator and a mechanical part such as a base table, press the emergency stop switch to release the brake on the subject arm, and then move the arm by hand.

- Get body caught in the arms:

The brake is not working. Move the arms manually.

- Get body caught in the shafts:

The brake is working. Press the brake release switch and move the shafts.

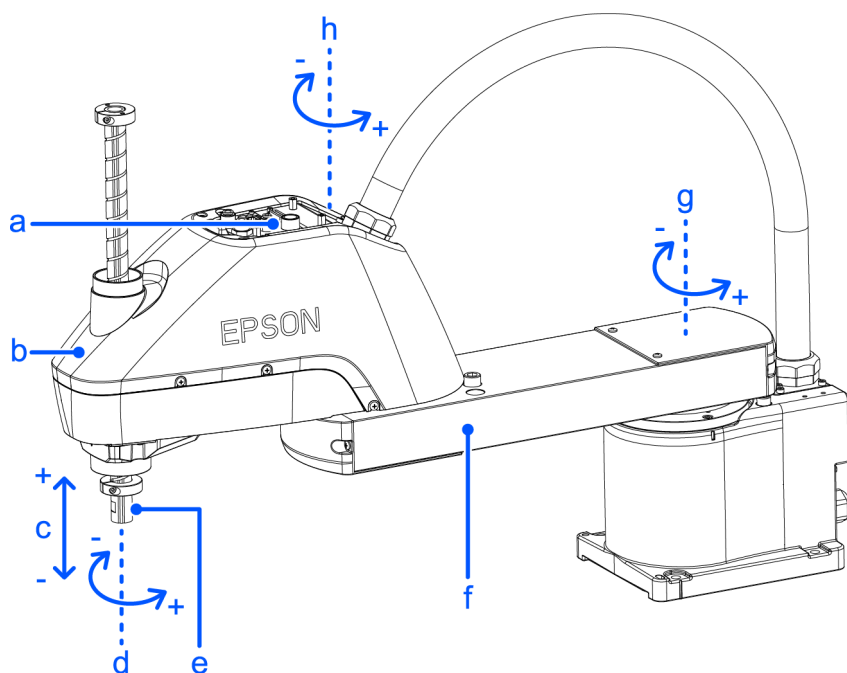

(Figure: LS8-C602S)

Symbol	Description
a	Joint #3 #4 Brake release switch
b	Arm #2
c	Joint #3 (up and down)
d	Joint #4 (rotating)
e	Shaft
f	Arm #1
g	Joint #1 (rotating)
h	Joint #2 (rotating)

**⚠ CAUTION**

Both Joint #3 and #4 may move due to its own weight while the brake release switch is pressed. Be careful of the shaft falling and rotating.

## 2.2 Specification

### 2.2.1 Model number

**Standard model**

**LS8-C60 2 S**  
└─┘ └─┘ └─┘ └─┘  
[a] [b] [c] [d]

- a: Payload
  - 4: 4 kg
  - 8: 8 kg
- b: Arm length
  - 40: 400 mm
  - 50: 500 mm
  - 60: 600 mm
  - 70: 700 mm
- c: Joint #3 stroke
  - 1: 150 mm (Standard environment specification)/120 mm (Cleanroom+ESD environment (bellows included))
  - 2: 200 mm (Standard environment specification)/170 mm (Cleanroom+ESD environment (bellows included))
- D: Environment
  - S: Standard
  - C: Cleanroom + ESD

**About the Environment**

Cleanroom + ESD (Anti-static measures) environment specification

The cleanroom + ESD environment specification is a product that is based on the standard environment specification, which reduces dust emission from the Manipulator so that it can be used in the cleanroom. The specifications are anti-static, including plating on necessary resin cover parts. The voltage at the end of the Manipulator (tool attachment part) has been confirmed to be below ±5 V even after the measurement based on our standards.

For more detailed information, contact the supplier.

Also, make sure to confirm the amount of charge of the hand that will be attached to the robot and wires.

For details on the specifications, refer to the following.

**Appendix B: Specification Table**

**List of Models**

Payload	Arm length	Environment	Joint #3 stroke	Model number
4 kg	400 mm	Standard	150 mm	LS4-C401S
		Cleanroom + ESD	120 mm	LS4-C401C
8 kg	500 mm	Standard	200 mm	LS8-C502S
		Cleanroom + ESD	170 mm	LS8-C502C
	600 mm	Standard	200 mm	LS8-C602S

		Cleanroom + ESD	170 mm	LS8-C602C
	700 mm	Standard	200 mm	LS8-C702S
		Cleanroom + ESD	170 mm	LS8-C702C

## 2.2.2 Part Names and Outer Dimensions

### 2.2.2.1 LS4-C

Standard environment specification (LS4-C401S)

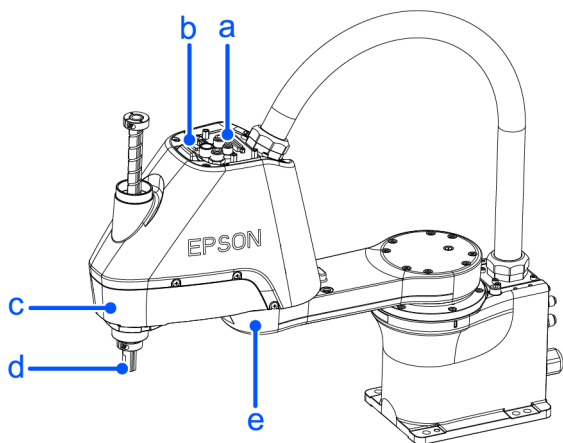

Symbol	Description
a	Joint #3.4 Brake release switch
b	LED lamp
c	Arm #2
d	Shaft
e	Arm #1

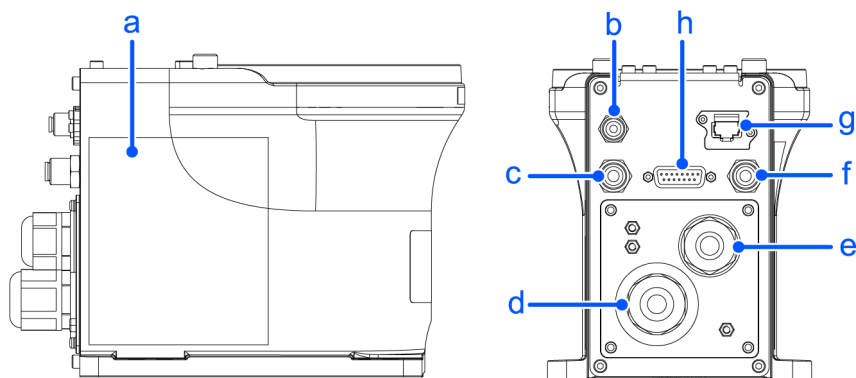

Symbol	Description
a	Signature label (Serial No. of Manipulator)

Symbol	Description
b	Blue (Fittings for $\varnothing 4$ mm pneumatic tube)
c	Blue (Fittings for $\varnothing 6$ mm pneumatic tube)
d	Power cable
e	Signal Cable
f	White (Fittings for $\varnothing 6$ mm pneumatic tube)
g	Ethernet connector
h	User connector (15 pin D-sub)

### KEY POINTS

- The brake release switch affects both Joints #3 and #4. When the brake release switch is pressed in emergency mode, the brake for both Joints #3 and #4 are released simultaneously.
- While the LED lamp is on, current is being applied to the Manipulator. Performing any work with the power ON is extremely hazardous and may result in electric shock and/or malfunction of the robot system. Make sure to turn OFF the controller power before maintenance work.

**Standard environment specification (LS4-C401S)**

If you are to install objects that may interfere with the robot, make sure to obtain enough clearance from the dimensions described below:

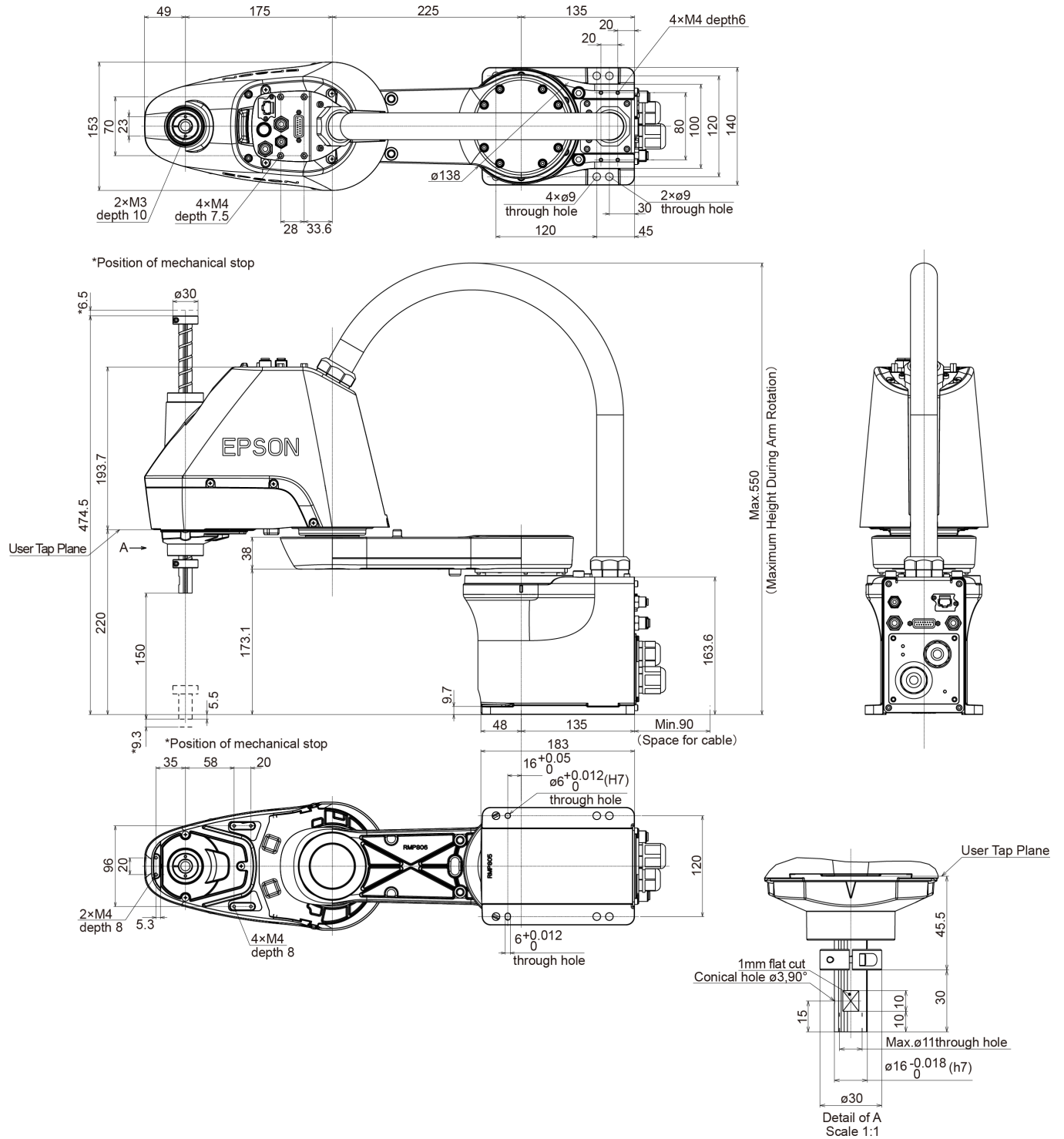

**Cleanroom + ESD Specification (LS4-C401C)**

The appearance of the cleanroom + ESD specification differs from the standard environment specification in the following parts:

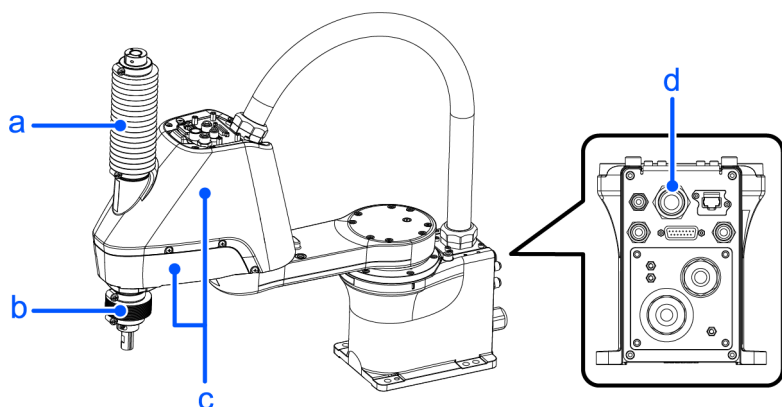

Symbol	Description
a	Upper bellows
b	Lower bellows
c	Plating cover (Anti-static)
d	Exhaust port

### Cleanroom + ESD Specification (LS4-C401C)

If you are to install objects that may interfere with the robot, make sure to obtain enough clearance from the dimensions described below:

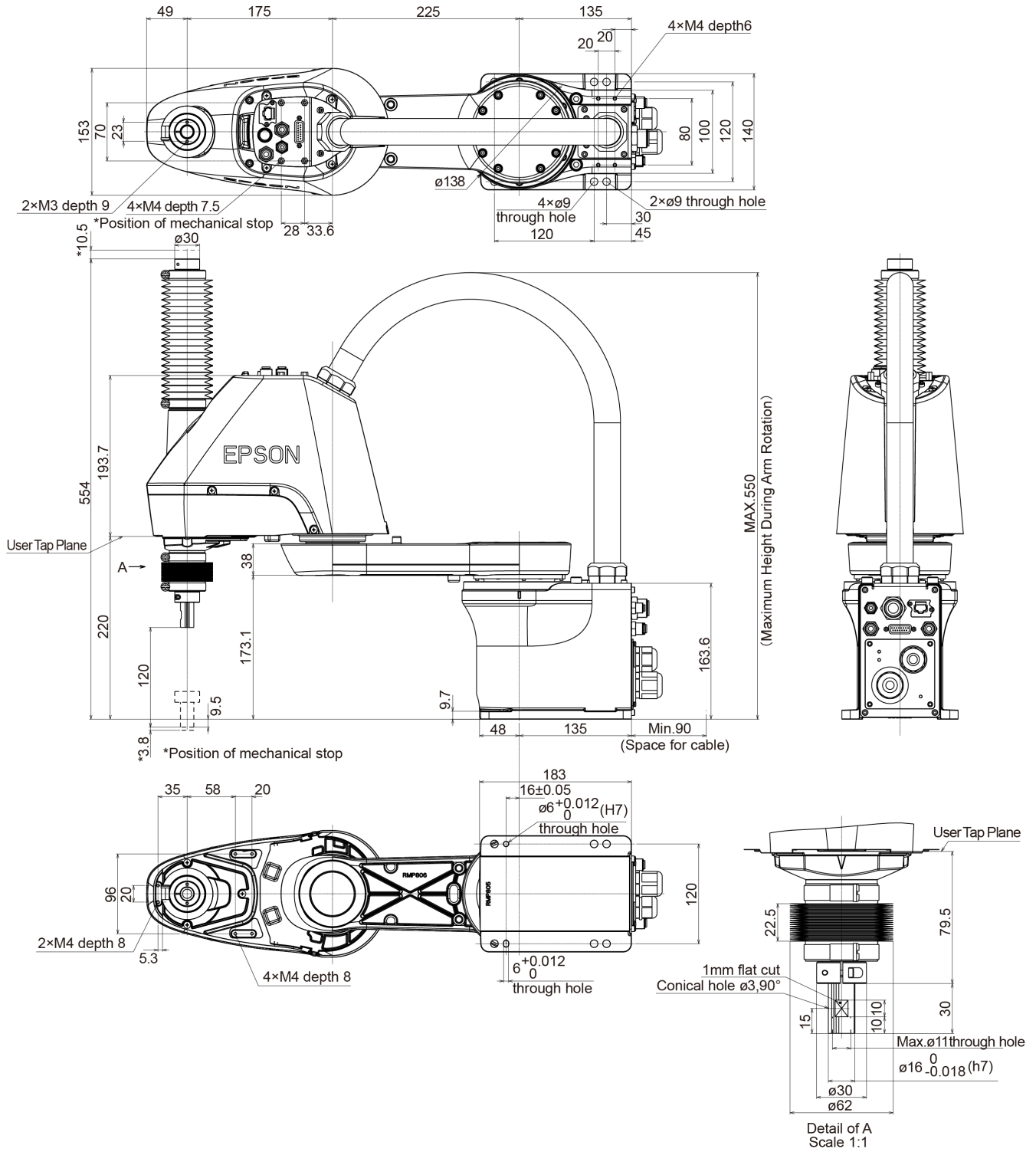

### 2.2.2.2 LS8-C

#### Standard environment specification (LS8-C\*02S)

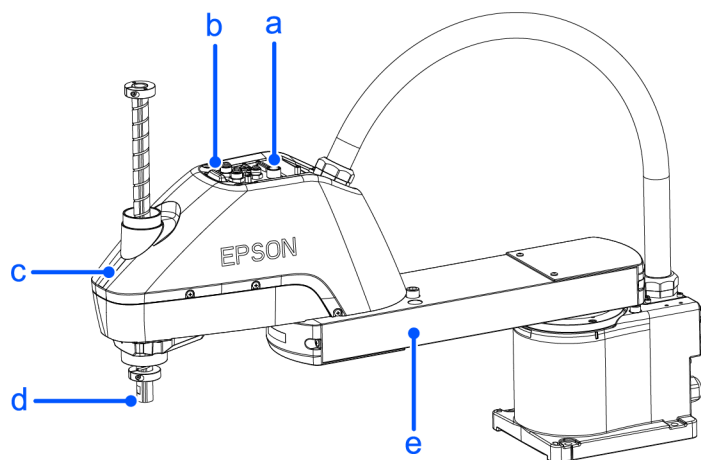

Symbol	Description
a	Joint #3 #4 Brake release switch
b	LED lamp
c	Arm #2
d	Shaft
e	Arm #1

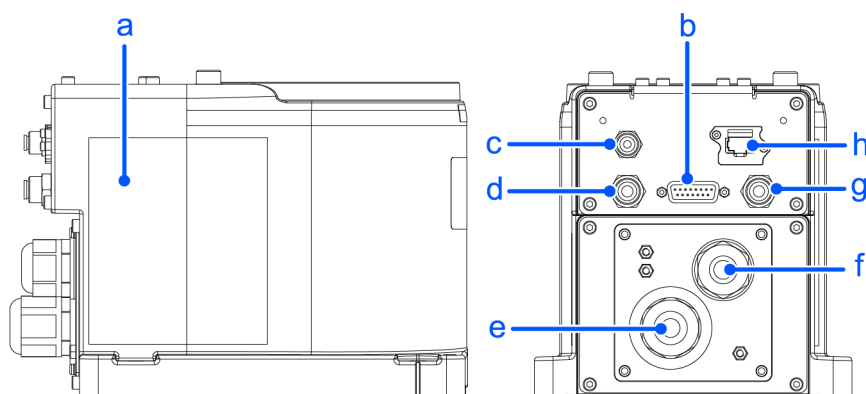

Symbol	Description
a	Signature label (Serial No. of Manipulator)
b	User connector (15 pin D-sub)
c	Blue (Fittings for ø4 mm pneumatic tube)
d	Blue (Fittings for ø6 mm pneumatic tube)
e	Power cable
f	Signal Cable
g	White (Fittings for ø6 mm pneumatic tube)

Symbol	Description
h	Ethernet connector

### KEY POINTS

- The brake release switch affects both Joints #3 and #4. When the brake release switch is pressed in emergency mode, the brake for both Joints #3 and #4 are released simultaneously.
- While the LED lamp is on, current is being applied to the Manipulator. Performing any work with the power ON is extremely hazardous and may result in electric shock and/or malfunction of the robot system. Make sure to turn OFF the controller power before maintenance work.

**Standard environment specification (LS8-C\*02S)**

If you are to install objects that may interfere with the robot, make sure to obtain enough clearance from the dimensions described below:

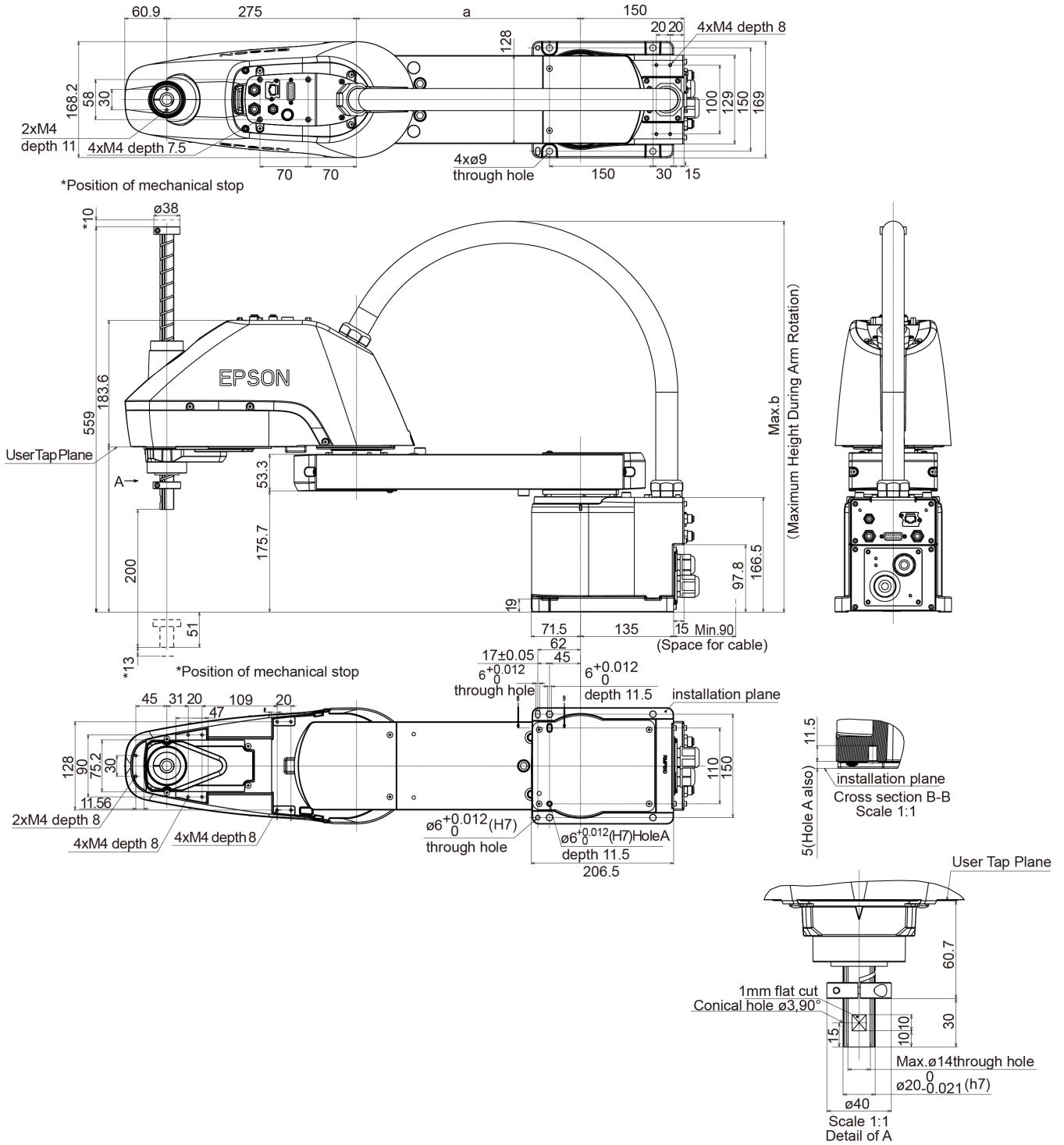

	LS8-C502S	LS8-C602S	LS8-C702S
--	-----------	-----------	-----------

---

a	225	325	425
b	560	590	620

**Cleanroom + ESD Specification (LS8-C\*02C)**

The appearance of the cleanroom + ESD specification differs from the standard environment specification in the following parts:

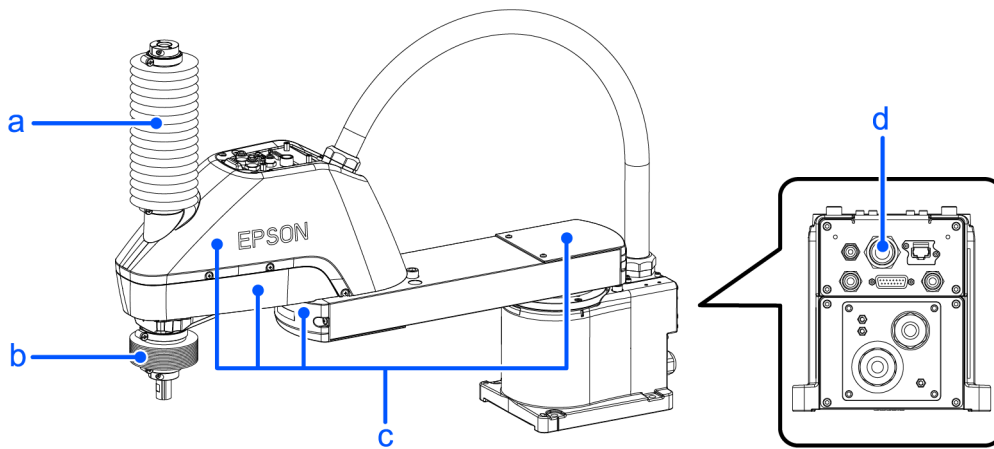

Symbol	Description
a	Upper bellows
b	Lower bellows
d	Plating cover (Anti-static)
c	Exhaust port

**Cleanroom + ESD Specification (LS8-C\*02C)**

If you are to install objects that may interfere with the robot, make sure to obtain enough clearance from the dimensions described below:

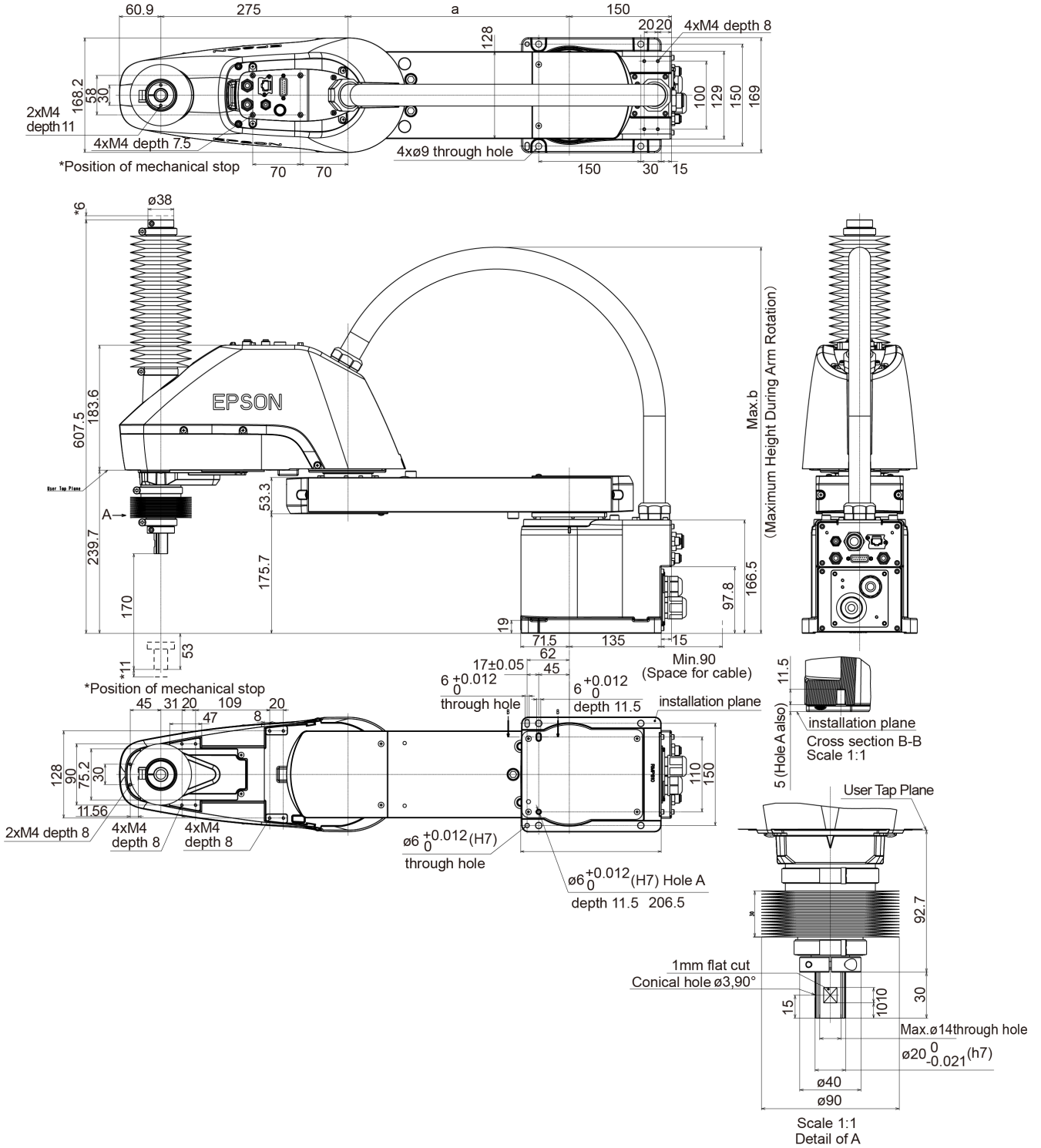

	LS8-C502C	LS8-C602C	LS8-C702C
--	-----------	-----------	-----------

a	225	325	425
b	560	590	620

### 2.2.3 Specification table

For details on the specifications of each model, refer to the following:

#### Appendix B: Specification Table

### 2.2.4 How to Set the Model

The Manipulator model for your system has been set before shipment from the factory.

#### CAUTION

- When changing the setting of the Manipulator model, be responsible and absolutely certain that the wrong Manipulator model is not set. Incorrect setting of the Manipulator model may result in abnormal or no operation by the Manipulator and could even cause safety problems.

If a custom specifications number (MT\*\*\*) or (X\*\*\*) is written on the face plate (serial number label), the Manipulator has custom specifications. (Depending on when it was shipped, a label with only the custom specification number may be applied.)

Models with custom specifications may require a different setting procedure. Check the custom specification number (MT\*\*\*) or (X\*\*\*) and contact the supplier.

The model settings of the Manipulator can be done using a software. For details, refer to the following manual. “Epson RC+ User’s Guide - Robot Settings”

## 2.3 Environment and Installation

The robot system should be designed and installed by people who have received installation training provided by Epson and the suppliers. Also, the laws and regulations of the installation country must be followed.

### 2.3.1 Environment

A suitable environment is necessary for the robot system to function properly and safely. Be sure to install the robot system in an environment that meets the following conditions:

Item	Conditions
Ambient Temperature *	5 to 40°C
Ambient relative humidity	10 to 80 % (no condensation)
Fast transient burst noise	1 kV or less (Signal wire)
Electrostatic noise	4 kV or less
Altitude	1000 m or lower

Item	Conditions
Environment	<ul style="list-style-type: none"> <li>▪ Install indoors</li> <li>▪ Keep away from direct sunlight</li> <li>▪ Keep away from dust, oily smoke, salinity, metal powder and other contaminants</li> <li>▪ Keep away from flammable or corrosive solvents and gases</li> <li>▪ Keep away from water</li> <li>▪ Keep away from shock or vibration</li> <li>▪ Keep away from sources of electric noise</li> <li>▪ Keep away from explosive area</li> <li>▪ Keep away from a large quantity of radiation</li> <li>▪ Keep away from organic solvents, acids, alkalis, chlorine-based cutting fluids, etc.</li> </ul>

\* The ambient temperature conditions are for the Manipulator only. For the Controller the Manipulators are connected to, refer to the Controller Manual.

 **KEY POINTS**

- Manipulators are not suitable for operation in harsh environments such as painting areas, etc. When using Manipulators in inadequate environments that do not meet the above conditions, please contact the supplier of your region.
- When the product is used in a low temperature environment around the minimum temperature of the product specification, or when the product is suspended for a long time on holidays or at night, a collision detection error may occur due to the large resistance of the drive unit immediately after the start of operation. In such case, it is recommended to warm up for about 10 minutes.

**Special Environmental Conditions**

The surface of the Manipulator has general oil resistance. However, if your requirements specify that the Manipulator must withstand certain kinds of oil, please contact the supplier of your region.

Rapid change in temperature and humidity can cause condensation inside the Manipulator.

If your requirements specify that the Manipulator handles food, please contact the supplier of your region to check whether the Manipulator will damage the food or not.

The Manipulator cannot be used in corrosive environments where acid or alkaline is used. In a salty environment where the rust is likely to gather, the Manipulator is susceptible to rust.

 **WARNING**

- Always use a circuit breaker for the Controller's power supply. Failure to use a circuit breaker may result in an electrical shock hazard or malfunction due to an electrical leakage. Select the correct circuit breaker based on the Controller that you are using. For details, refer to the following manual.

## "Robot Controller Manual"

**⚠ CAUTION**

- When cleaning the Manipulator, do not rub it strongly with alcohol or benzene. Coated surfaces may lose their luster.

**2.3.2 Base Table**

Please make or obtain the base table to secure your Manipulator.

The shape and size of the base table differs depending on the use of the robot system. For your reference, we list some Manipulator table requirements here.

The base table must not only be able to bear the weight of the Manipulator but also be able to withstand the dynamic movement of the Manipulator when it operates at maximum acceleration/deceleration. Ensure that there is enough strength on the base table by attaching reinforcing materials such as crossbeams.

The torque and reaction force produced by the movement of the Manipulator are as follows:

	LS4-C	LS8-C
Max. reaction torque on the horizontal plate	330 N·m	610 N·m
Max. horizontal reaction force	1300 N	1900 N
Max. vertical reaction force	970 N	1200 N

**⚠ CAUTION**

If the vibration of the base table is large, reduce the acceleration/deceleration or increase the rigidity of the base table to reduce the vibration. Continued use in a state of large vibration may cause loosening of fastening parts or excessive load on mechanical parts, which may shorten the lifespan.

The threaded holes required for mounting the Manipulator base are M8. Use mounting bolts with specifications conforming to ISO898-1 property class 10.9 or 12.9. For dimensions, refer to the following.

**Mounting Dimensions**

The plate for the Manipulator mounting face should be 20 mm thick or more and made of steel to reduce vibration. The surface roughness of the steel plate should be 25 μm or less.

The table must be secured on the floor or wall to prevent it from moving.

The Manipulator installation surface should have a flatness of 0.5 mm or less and an inclination of 0.5° or less. If the flatness of the installation surface is improper, the base may be damaged, or the robot may not fully show its performance.

When using a leveler to adjust the height of the base table, use a screw with M16 diameter or more.

If you are passing cables through the holes on the base table, see the figures below.

(Unit: mm)

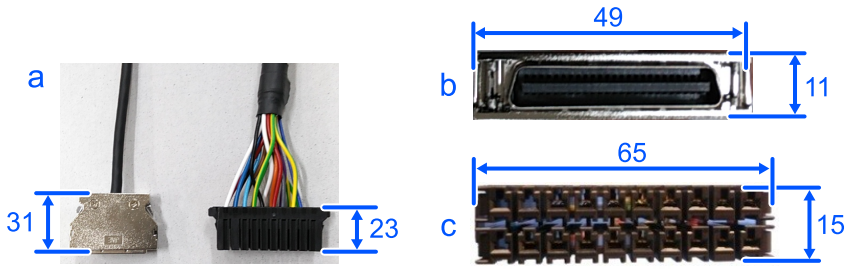

Symbol	Description
a	M/C Cables
b	Signal Cable Connector
c	Power Cable Connector

**KEY POINTS**

Do not remove the M/C cable from the Manipulator.

For environmental conditions regarding space when placing the Controller on the base table, refer to the Controller manual.

**WARNING**

To ensure safety, a safeguard must be installed for the robot system. For details on the safeguard, refer to the Epson RC+ User's Guide.

**2.3.3 Mounting Dimensions**

The maximum space (R) includes the radius of the end effector. If it exceeds 60 mm, define the radius as the distance to the outer edge of maximum space. If a camera or solenoid valve extends outside of the arm, set the maximum range including the space that they may reach.

Be sure to allow for the following extra spaces in addition to the space required for mounting the Manipulator, Controller, and peripheral equipment.

- Space for teaching
- Space for maintenance and inspection (Ensure a space to open the covers and plates for maintenance.)
- Space for cables

**KEY POINTS**

- When installing the cable, be sure to maintain sufficient distance from obstacles.
- For the minimum bend radius of the MC cable, refer to the following:  
[LS4-C Specification Table](#)  
[LS8-C Specification Table](#)
- Also, leave enough space for other cables so that they are not forced to bend at extreme angles.

Ensure distance to the safeguard from the maximum motion range is more than 100 mm.

If you are to install objects that may interfere with the robot, secure enough clearance from the maximum range.

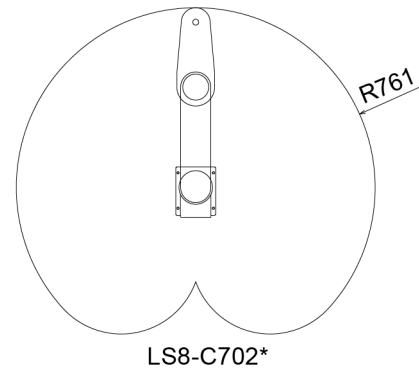
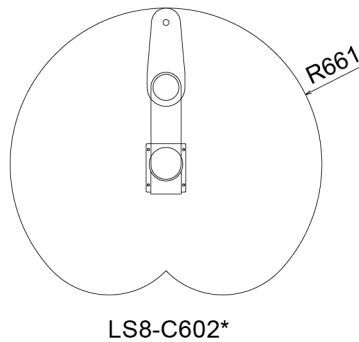
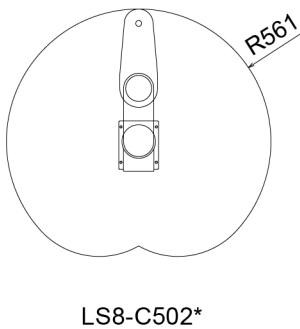
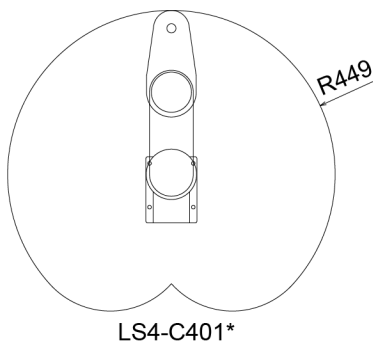

### 2.3.4 Unpacking and Transportation

Transportation and installation of the Manipulators shall be performed by personnel who has taken robot system training held by us and suppliers and should conform to all national and local codes.

#### **⚠ WARNING**

Only authorized personnel should perform sling work and operate a crane and a forklift. When these operations are performed by unauthorized personnel, it is extremely hazardous and may result in serious bodily injury and/or severe equipment damage to the robot system.

#### **⚠ CAUTION**

- Using a cart or similar equipment, transport the Manipulator in the same manner as it was delivered. When transporting the Manipulator, do not attach the MC cable.
- After removing the bolts securing the Manipulator to the delivery equipment, the Manipulator can fall. Be careful not to get hands or fingers caught.
- To carry the Manipulator, have two or more people to work on it and secure the Manipulator to the delivery equipment. Also, do not hold the shaded area in the figure. Doing so is extremely dangerous and can result in getting your hands and fingers caught.

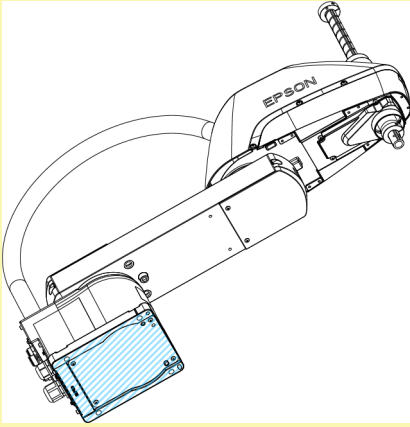

(Figure: LS8-C)

- LS4-C401\*: approx. 14 kg: 30.9bs. (pound)
  - LS8-C502\*: approx. 19 kg: 41.9 lbs. (pound)
  - LS8-C602\*: approx. 20 kg: 44.1 lbs. (pound)
  - LS8-C702\*: approx. 21 kg: 46.3 lbs. (pound)
- Stabilize the Manipulator with your hands when hoisting it. If you lose balance, the Manipulator may fall which could result in serious bodily injury and/or severe equipment damage.
  - When transporting the Manipulator for a long distance, secure it to the delivery equipment directly so that the Manipulator never falls over. If necessary, pack the Manipulator in the same style as it was delivered.

## 2.3.5 Installation Procedure

Installation of the Manipulator and related equipment should be performed by people who have received installation training provided by Epson and the suppliers. Also, the laws and regulations of the installation country must be followed.

### CAUTION

- The robot system must be installed to avoid interference with buildings, structures, utilities, other machines and equipment that may create a trapping hazard or pinch points.
- When installing the robot, make sure to secure enough space to work.
- Vibration (resonance) may occur during operation depending on rigidity of the base table. If vibration occurs, improve rigidity of the table or change the speed or acceleration and deceleration settings

### 2.3.5.1 Standard Environment Specification

#### CAUTION

Install and move the Manipulator with two or more people. The Manipulator weights are as follows. Be careful not to get hands or feet caught and/or have equipment damaged by the Manipulator falling.

- LS4-C401\*: approx. 14 kg: 30.9 lbs. (pound)
- LS8-C502\*: approx. 19 kg: 41.9 lbs. (pound)
- LS8-C602\*: approx. 20 kg: 44.1 lbs. (pound)

▪ LS8-C702\*: approx. 21 kg: 46.3 lbs. (pound)

Secure the base to the base table with four bolts.

**KEY POINTS**  
Use bolts with specifications conforming to ISO898-1 Property Class 10.9 or 12.9.

Tightening torque: 32.0 N·m (326 kgf·cm)

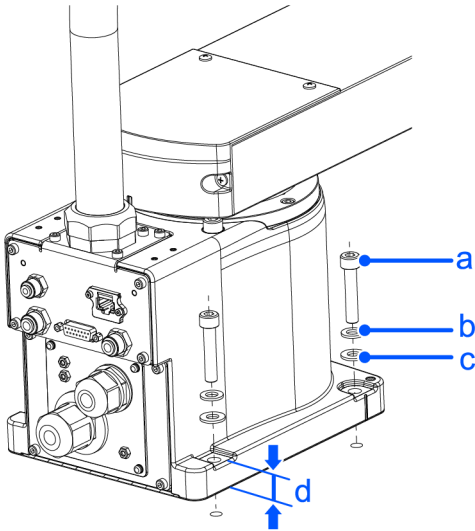

Symbol	Description
a	M8 screws
b	Spring Washer
c	Plain Washer
d	LS4-C: 10 mm LS8-C: 19 mm

**2.3.5.2 Cleanroom Environment Specification**

1. Unpack the Manipulator outside of the cleanroom.
2. Secure the Manipulator to transporting equipment (or a pallet) with bolts so that the Manipulator does not fall down.
3. Wipe off any dust on the Manipulator using a lint-free cloth that was dipped in ethyl alcohol or distilled water.
4. Carry the Manipulator into the cleanroom.
5. Referring to the standard specification’s installation procedure, install the Manipulator.
6. Connect an exhaust tube to the exhaust port.

## 2.3.6 Connecting the Cables

### ⚠ WARNING

- To shut off power to the robot system, disconnect the power plug from the power source or use a disconnecter. Be sure to connect the AC power cable to either a power receptacle or a disconnecter. **DO NOT** connect it directly to a factory power source.
- Before performing any replacement procedure, turn OFF the Controller and related equipment, and then disconnect the power plug from the power source. Performing any replacement procedure with the power ON is extremely hazardous and may result in electric shock and/or malfunction of the robot system.
- Be sure to connect the cables properly. Do not allow unnecessary strain on the cables. (Do not put heavy objects on the cables. Do not bend or pull the cables forcibly.) The unnecessary strain on the cables may result in damage to the cables, disconnection, and/or contact failure.
- Grounding the manipulator is done by connecting with the controller. Ensure that the controller is grounded and the cables are correctly connected. If the ground wire is improperly connected to ground, it may result in the fire or electric shock.

### ⚠ CAUTION

- When connecting the Manipulator to the Controller, make sure that the serial numbers on each equipment match. Improper connection between the Manipulator and Controller may not only cause improper function of the robot system but also serious safety problems. The connection method varies with the Controller used. For details on the specifications, refer to the Controller manual.
- Connecting cables to the Manipulator shall be performed by personnel who has taken robot system training held by us and suppliers. This should also be performed by qualified personnel with knowledge and skills in electricity. Wiring by unauthorized or uncertified staff may result in bodily injury and/or malfunction of the robot system.

When the Manipulator is a model with cleanroom & ESD specifications, an exhaust system must be connected.

For the exhaust system, refer to the following section.

### Appendix B: Specification Table

#### Method to Connect the Manipulator and M/C Cable

1. Set the M/C cable as shown below.

### ✍ KEY POINTS

Be careful with the direction of the plate.

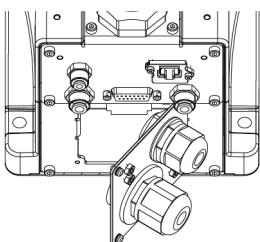

(Figure: LS8-C\*02)

2. Connect the following connectors in the order shown below.

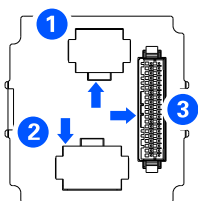

3. Install the plate.

### KEY POINTS

Be careful not to tighten the screws with the cables caught on the plate.

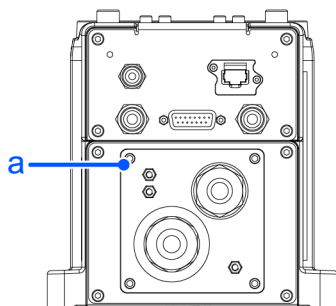

(Figure: LS8-C\*02)

Tightening torque:  $0.6 \pm 0.1 \text{ N} \cdot \text{m}$

Symbol	Description
a	Cross screw: M3× 6 (4)

### Diagram of Cable Connection

Connect the power connector and the signal connector of the M/C cable with each Controller.

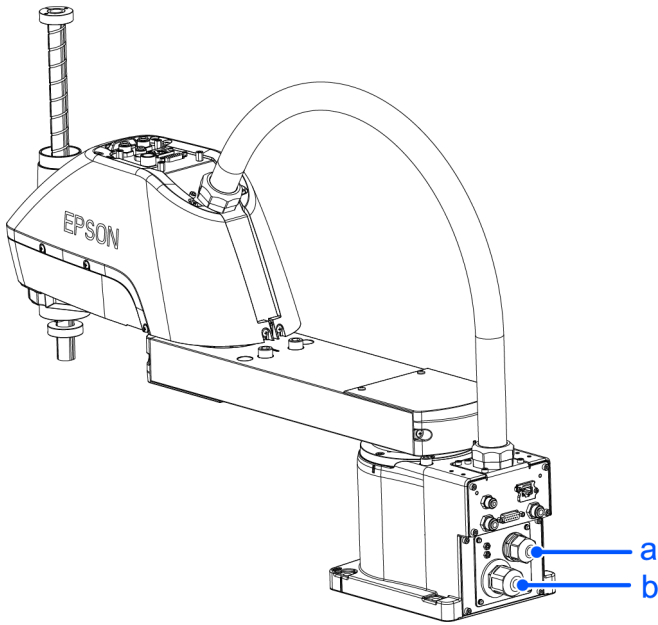

Symbol	Description
a	Signal Connector
b	Power Connector

### 2.3.7 Installed wire for customer use

**⚠ CAUTION**

- Only authorized or certified personnel should perform wiring. Wiring by unauthorized or uncertified staff may result in bodily injury and/or malfunction of the robot system.

User electrical wires and pneumatic tubes are contained in the cable unit.

#### Electrical Wires

Rated Voltage	Allowable Current	Wires	Nominal Sectional Area	Note
AC/DC30V	1A	15	0.216 mm <sup>2</sup>	Twist pair

**⚠ WARNING**

Do not apply the current more than 1A to the manipulator.

		Manufacturer	Standard
15 pin	Compatible connector	Fu-yao	DB-15MKAC00B0 (Solder type)
	Clamp Hood	Fu-yao	C03-15CLACAA0 (Connectors setscrew: #4-40 NC)

Pins with the same number, indicated on the connectors on both ends of the cables, are connected.

## Pneumatic Tubes

Max. Usable Pneumatic Pressure	The number of bolts	Outer Diameter×Inner Diameter
0.59Mpa (6kgf/cm <sup>2</sup> :86psi)	2	ø6mm×ø4mm
	1	ø4mm×ø2.5mm

Fittings for ø6 mm and ø4 mm (outer diameter) pneumatic tubes are supplied on both ends of the pneumatic tubes.

## LS4-C

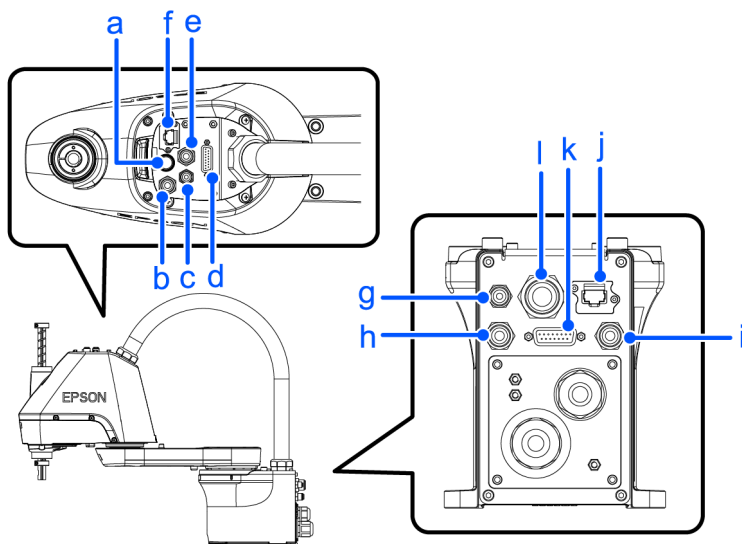

Symbol	Description
a	Joint #3.4 Brake release switch
b	White (Fittings for ø6 mm pneumatic tube)
c	Blue (Fittings for ø4 mm pneumatic tube)
d	Blue (Fittings for ø6 mm pneumatic tube)
e	User connector (15 pin D-sub)
f	RJ45 connector (Ethernet)
g	Blue (Fittings for ø4 mm pneumatic tube)
h	Blue (Fittings for ø6 mm pneumatic tube)
i	White (Fittings for ø6 mm pneumatic tube)
j	RJ45 connector (Ethernet)
k	User connector (15 pin D-sub)
l	Exhaust port (Cleanroom + ESD specification only)

## LS8-C

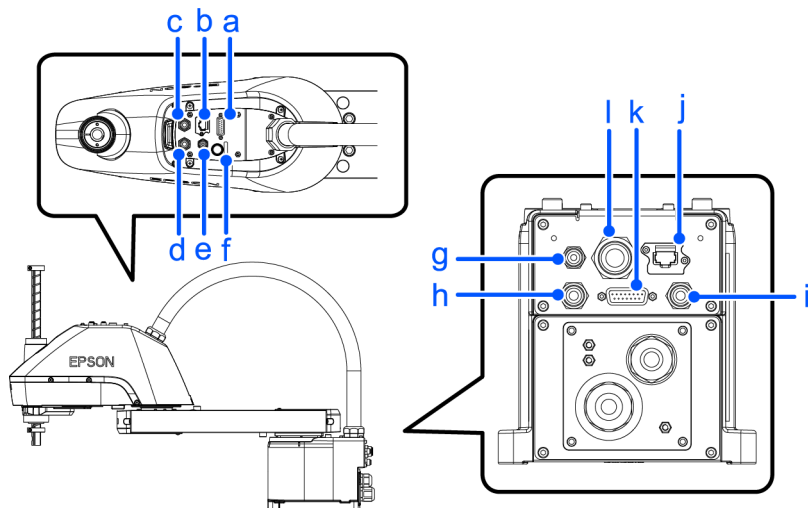

Symbol	Description
a	User connector (15 pin D-sub)
b	RJ45 connector (Ethernet)
c	White (Fittings for ø6 mm pneumatic tube)
d	Blue (Fittings for ø6 mm pneumatic tube)
e	Blue (Fittings for ø4 mm pneumatic tube)
f	Joint #3.4 Brake release switch
g	Blue (Fittings for ø4 mm pneumatic tube)
h	Blue (Fittings for ø6 mm pneumatic tube)
i	White (Fittings for ø6 mm pneumatic tube)
j	RJ45 connector (Ethernet)
k	User connector (15 pin D-sub)
l	Exhaust port (Cleanroom + ESD specification only)

## 2.3.8 Relocation and Storage

### 2.3.8.1 Precautions for Relocation and Storage

Observe the following when relocating, storing, and transporting the Manipulators.

Transportation and installation of the Manipulator and robotic equipment shall be performed by personnel who has taken robot system training held by us and suppliers and should conform to all national and local codes.

## WARNING

Only authorized personnel should perform sling work and operate a crane and a forklift. When these operations are performed by unauthorized personnel, it is extremely hazardous and may result in serious bodily injury and/or severe equipment damage to the robot system.

## CAUTION

- Before relocating the Manipulator, fold the arm and secure it tightly with a wire tie to prevent hands or fingers from being caught in the Manipulator. When transporting the Manipulator, remove the MC cable.
- When removing the anchor bolts, support the Manipulator to prevent falling. Removing the anchor bolts without support may result in the Manipulator to fall, and then get hands, fingers, or feet caught.
- To carry the Manipulator, have two or more people to work on it and secure the Manipulator to the delivery equipment. Also, do not hold the shaded area in the figure. Doing so is extremely dangerous and can result in getting your hands and fingers caught.

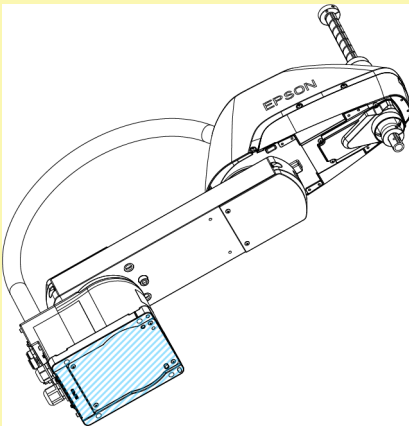

(Figure: LS8-C)

- LS4-C401\*: approx. 14 kg: 30.9 lbs. (pound)
- LS8-C502\*: approx. 19 kg: 41.9 lbs. (pound)
- LS8-C602\*: approx. 20 kg: 44.1 lbs. (pound)
- LS8-C702\*: approx. 21 kg: 46.3 lbs. (pound)
- Stabilize the Manipulator with your hands when hoisting it. If you lose balance, the Manipulator may fall which could result in serious bodily injury and/or severe equipment damage.

When transporting the Manipulator for a long distance, secure it to the delivery equipment directly so that the Manipulator never falls over. If necessary, pack the Manipulator in the same style as it was delivered.

When the Manipulator is used for a robot system again after long-term storage, perform a test run to verify that it works properly, and then operate it thoroughly.

Transport and store the Manipulator in the range of Temperature:  $-20$  to  $+60$  °C, Humidity: 10 to 90% (no condensation).

When condensation occurs on the Manipulator during transport or storage, turn ON the power only after the condensation dries.

Do not shock or shake the Manipulator during transport.

### 2.3.8.2 Relocation

#### **⚠ CAUTION**

Install or relocate the Manipulator with two or more people. The Manipulator weights are as follows. Be careful not to get hands or feet caught and/or have equipment damaged by the Manipulator falling.

- LS4-C401\*: approx. 14 kg: 30.9 lbs. (pound)
- LS8-C502\*: approx. 19 kg: 41.9 lbs. (pound)
- LS8-C602\*: approx. 20 kg: 44.1 lbs. (pound)
- LS8-C702\*: approx. 21 kg: 46.3 lbs. (pound)

Turn OFF the power on all devices and unplug the cables. Remove the mechanical stops if using them to limit the motion range of Joints #1 and #2. For details on the motion range, refer to the following section.

#### **Motion Range Setting by Mechanical Stops**

1. Set the Arm into the pose described below.
2. Attach M4 bolts to each tap on the Arm #2 side and base side.
3. Secure the Arm by connecting the M4 bolts together using wire ties as shown in the figure below:  
\*Use sheets to protect the Arm from getting damaged if necessary.

#### **Example of Securing the Arm**

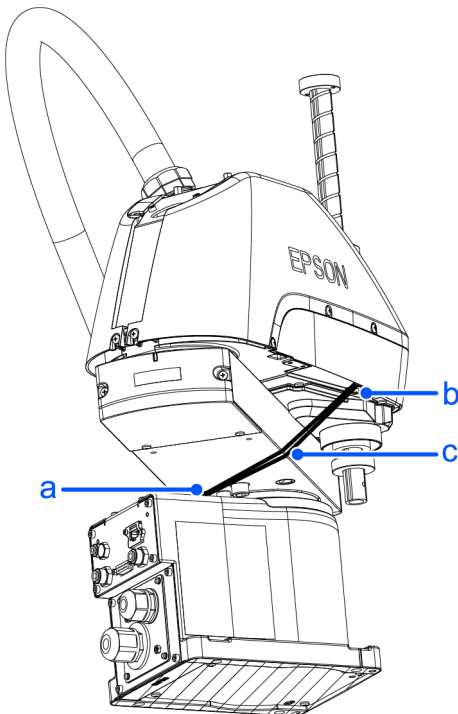

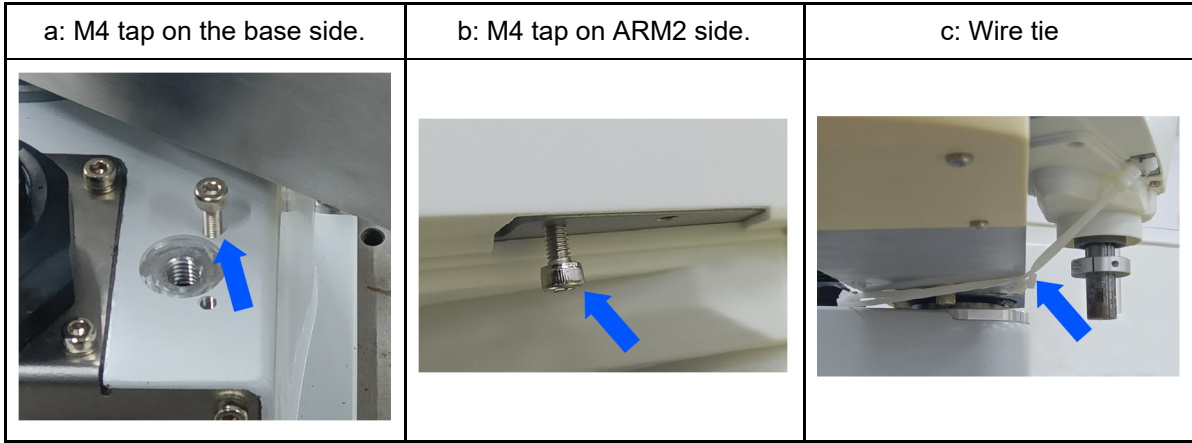

Hold the bottom of Arm #1 by hand to unscrew the anchor bolts. Then, remove the Manipulator from the base table.

**LS4-C401\***

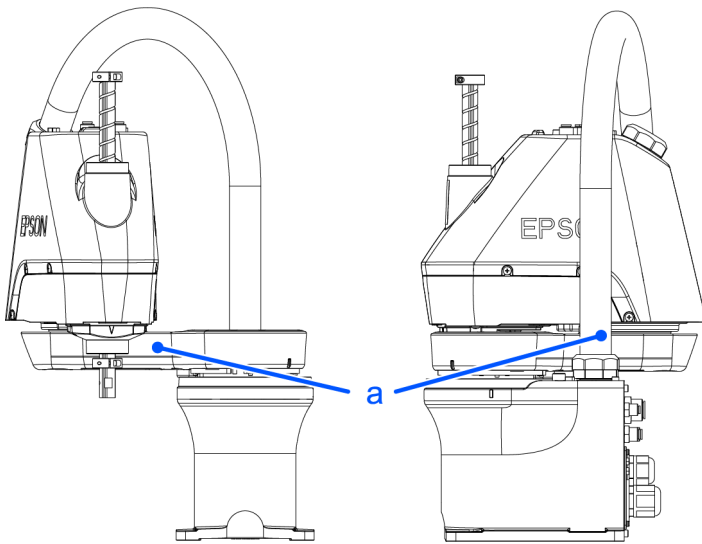

**LS8-C502\***

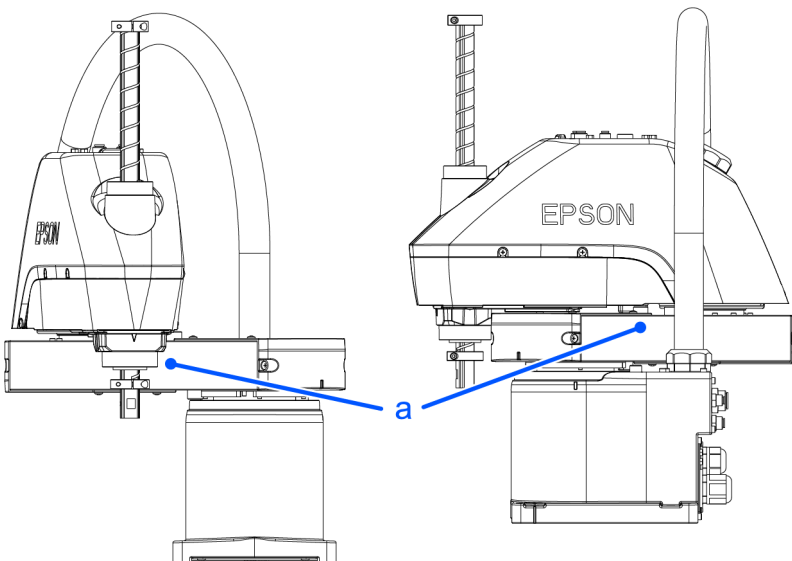

**LS8-C602\***

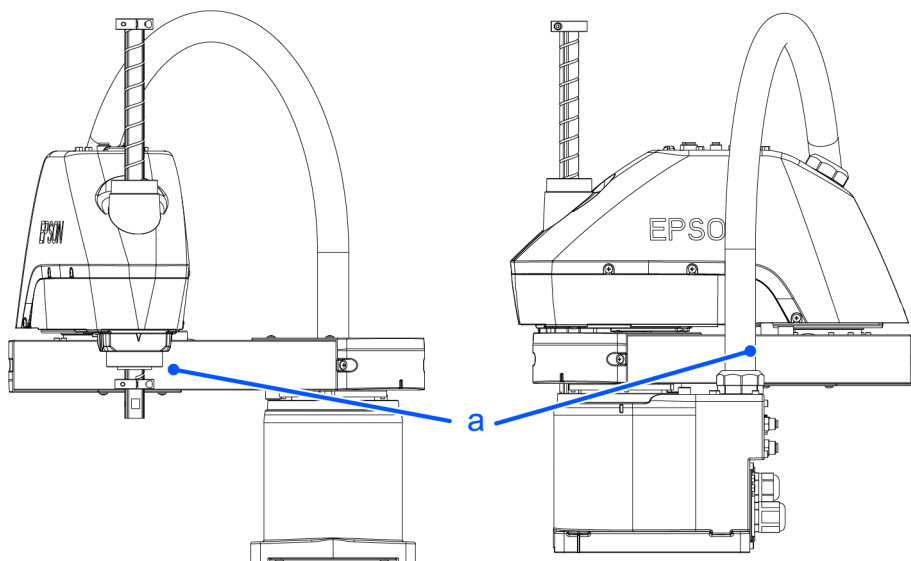

**LS8-C702\***

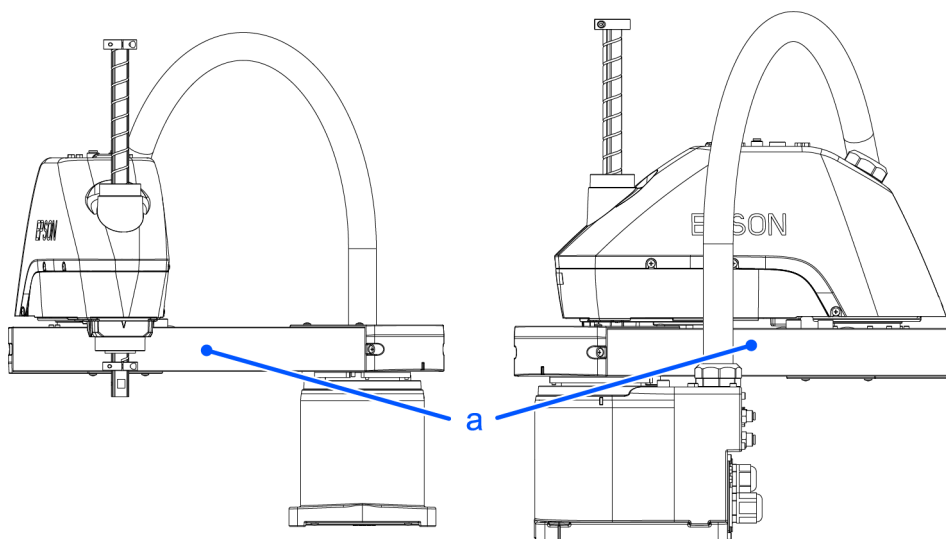

Symbol	Description
a	Center of gravity

## 2.4 Setting of End Effectors

### 2.4.1 Attaching and End Effector

Users are responsible for making their own end effector(s). Be careful of the following points when attaching an end effector. For details on attaching a hand, refer to the following manual:

"Hand Function Manual"

**⚠ CAUTION**

- If you use an end effector equipped with a gripper or chuck, connect wires and/or pneumatic tubes properly so that the gripper does not release the workpiece when the power to the robot system is turned OFF. Improper connection of the wires and/or pneumatic tubes may damage the robot system and/or work piece as the work piece is released when the Emergency Stop switch is pressed.
- I/O outputs are configured at the factory so that they are automatically shut off (0) by power disconnection, the Emergency Stop switch, or the safety features of the robot system. However, the I/O set in the hand function does not turn off (0) when the Reset command is executed or in emergency stop.

**Shaft**

- Attach an end effector to the lower end of the shaft. For the shaft dimensions, and the overall dimensions of the Manipulator, refer to the following.

**Specification**

- Do not move the upper limit mechanical stop on the lower side of the shaft. Otherwise, when "Jump motion" is performed, the upper limit mechanical stop may hit the Manipulator, and the robot system may not function properly.
- Use a split muff coupling with an M4 bolt or larger to attach the end effector to the shaft.

**Brake release switch**

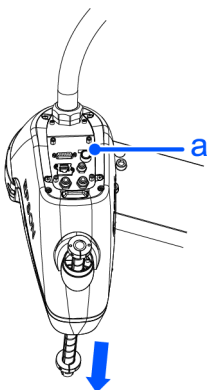

(Figure: LS8-C\*02S)

Shaft may be lowered by the weight of the end effector.

Symbol	Description
a	Brake release switch

- Joint #3 and #4 cannot be moved up/down by hand because the electromagnetic brake is applied to the joint while power to the robot system is turned OFF. This prevents the shaft from hitting peripheral equipment in the case that the shaft is lowered by the weight of the end effector when the power is disconnected during operation, or when the motor is turned OFF even though the power is turned ON.
- To move Joint #3 up/down or rotate Joint #4 while attaching an end effector, turn ON the Controller and move the joint up/down or rotate the joint while pressing the brake release switch. This button switch is a momentary-type; the brake is released only while the button switch is being pressed

- When the brake is released, the shaft may be lowered by its own weight. Make sure to take measures to prevent the shaft from falling and work when you have confirmed that your surroundings are safe.
- Be careful of the shaft falling and rotating due to its weight while the brake release switch is being pressed.

**Layouts**

- When you operate the manipulator with an end effector, the end effector may interfere with the Manipulator because of the outer diameter of the end effector, the size of the workpiece, or the position of the arms. When designing your system layout, pay attention to the interference area of the end effector.

**2.4.2 Attaching Cameras and Valves**

Arm #2 has threaded holes as shown in the figure below. Use M4 threaded holes on the top when attaching Ethernet cable to the arm. Use M4 threaded holes on the bottom when attaching a camera or air valve to the arm.

The maximum allowable volume load of the threaded hole indicated in the figure above is 500 g\*.

\*The maximum allowable volume load when all four are used

(Unit: mm)

**LS4-C**

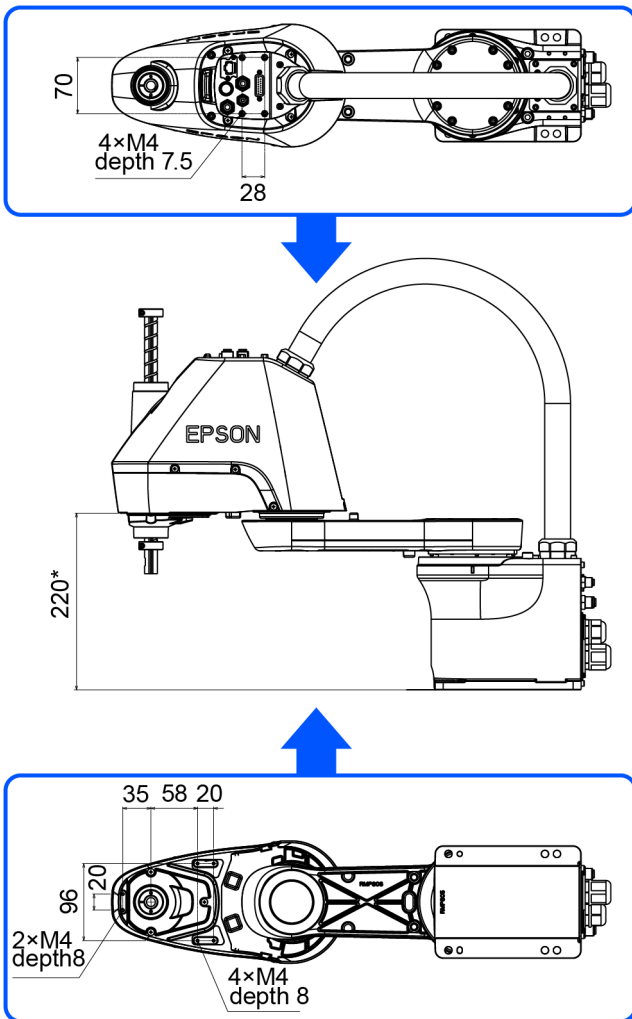

**LS8-C**

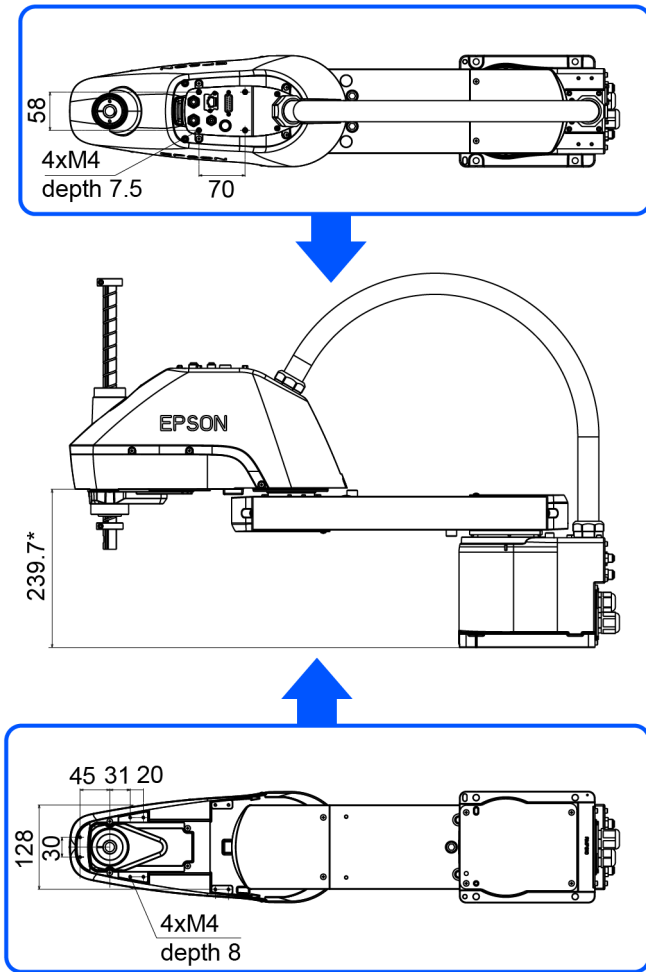

\*: From base installation surface

### 2.4.3 Weight and Inertia Settings

To ensure optimum Manipulator performance, it is important to make sure that the load (weight of the end effector and workpiece) and moment of inertia of the load are within the maximum rating for the Manipulator, and that Joint #4 does not become eccentric. If the load or moment of inertia exceeds the rating or if the load becomes eccentric, follow the steps below to set parameters.

- [Weight Setting](#)
- [Inertia Setting](#)

Setting parameters makes the PTP motion of the Manipulator optimal, reduces vibration to shorten the operating time, and improves the capacity for larger loads. In addition, it reduces persistent vibration produced when the moment of inertia of the end effector and work piece is larger than the default setting.

#### 2.4.3.1 Weight Setting

**⚠ CAUTION**

The total weight of the hand and the workpiece must not exceed 4 kg for LS4-C and 8 kg for LS8-C. The LS-C series are not designed to work with a moment of inertia exceeding 4 kg for LS4-C and 8 kg for LS8-C. Always set the value according to the load. Setting a value that is smaller than the actual load may cause errors, shock

and insufficient function of the Manipulator. Also, the life cycle of parts will shorten and belt tooth jumping will occur which will lead to position shift.

The acceptable weight capacity (end effector and workpiece) in LS-C series

- LS4-C: Rating: 2 kg Maximum:4 kg
- LS8-C: Rating: 3 kg Maximum:8 kg

If the load weight exceeds the rated weight, change the setting for the hand weight parameter in the Weight command. After the setting is changed, the maximum acceleration/deceleration speed of the robot system at PTP motion corresponding to the “Weight Parameter” is set automatically.

### 2.4.3.2 Load on the Shaft

The load (weight of the end effector and work piece) on the shaft can be set by Weight parameter.

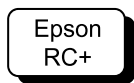

Enter a value into the [Weight:] text box on the [Weight] panel ([Tools]-[Robot Manager]). (You may also execute the Weight command from the [Command Window].)

### 2.4.3.3 Load on the Arm

When you attach a camera, valve or other devices to the arm, calculate the weight as the equivalent of the shaft. Then, add this to the weight of the load attached to the shaft, and enter the total weight to the Weight parameter.

#### Equivalent Weight Formula

$$W_M = M(L_M + L_1)^2 / (L_1 + L_2)^2$$

$W_M$	equivalent weight
$M$	Load on the Arm
$L_1$	Arm 1 length
$L_2$	Arm 2 length
$L_M$	Distance from rotation center of Joint #2 to center of gravity attached to the Arm.

Calculates [Weight] parameter when a “1 kg” camera is attached to the end of the LS8-C arm (375 mm away from the rotation center of Joint #2) with a load weight of “1 kg”.

$$W=1$$

$$M=1$$

$$L_1=375$$

$$L_2=275$$

$$L_M=375$$

$$W_M = 1 \times (375 + 325)^2 / (325 + 275)^2 = 1.26 \text{ (Round up to two decimal)}$$

$$W+W_M=1+1.36=2.36$$

Enter “2.36” for the Weight Parameter.

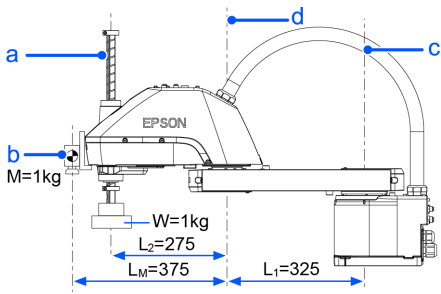

Symbol	Description
a	Shaft
b	Weight of the entire camera
c	Joint #1
d	Joint #2

### 2.4.3.4 Automatic speed setting by Weight

#### LS4-C401S

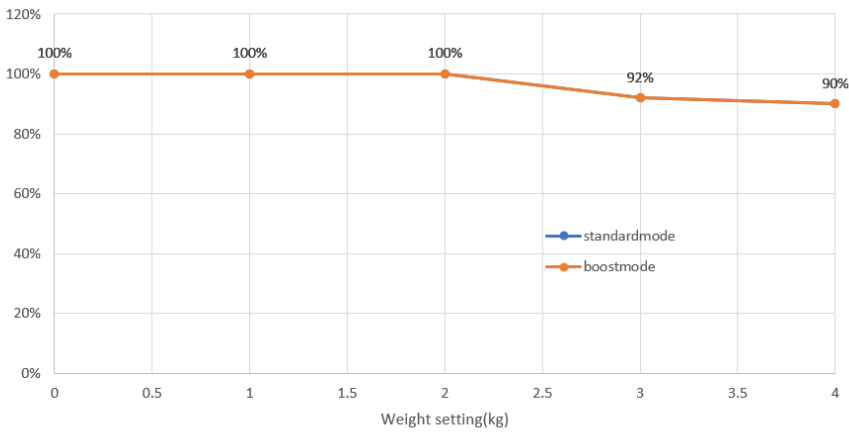

End effector weight (kg)	Automatic speed setting by Weight (%)
0	100
1	100
2 (Rated weight)	100
3	92
4	90

#### LS8-C502S

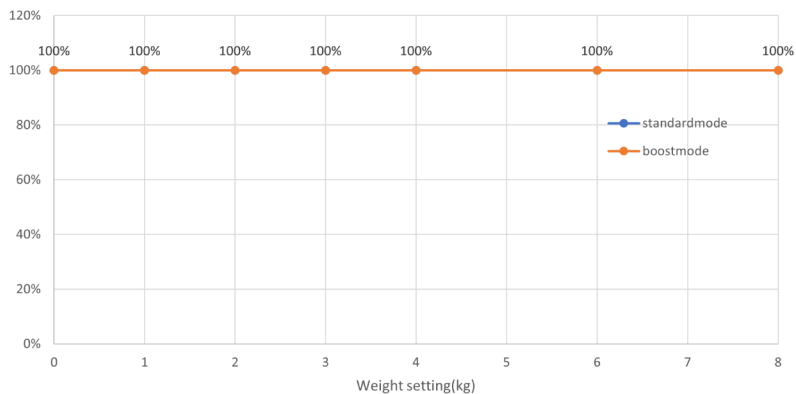

End effector weight (kg)	Automatic speed setting by Weight (%)
0	100
1	100
2	100
3 (Rated weight)	100
4	100
6	100
8	100

**LS8-C602S**

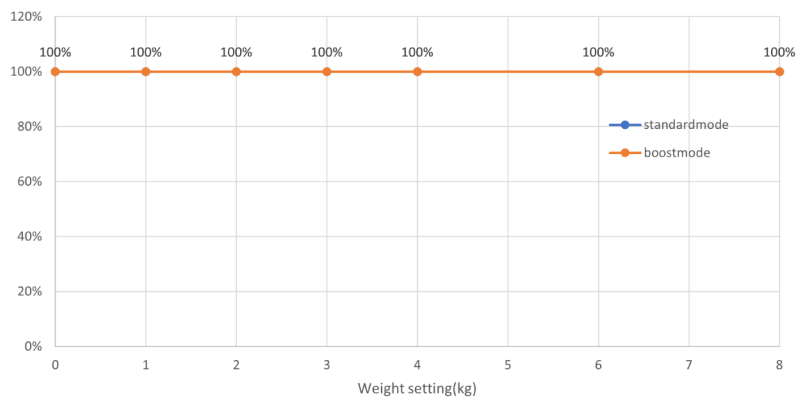

End effector weight (kg)	Automatic speed setting by Weight (%)
0	100
1	100
2	100
3 (Rated weight)	100
4	100
6	100
8	100

**LS8-C702S**

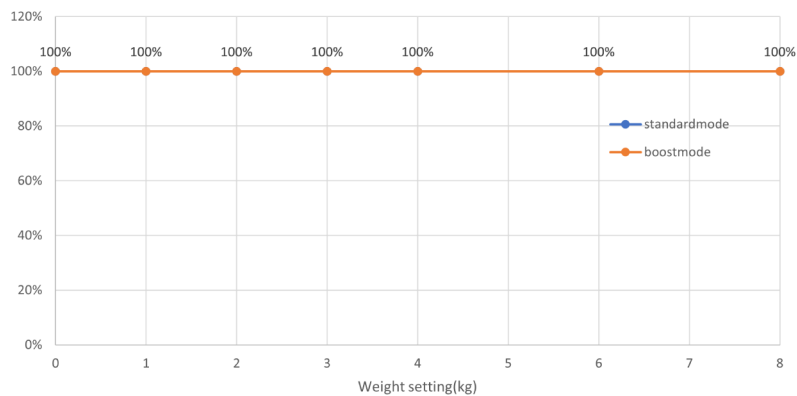

End effector weight (kg)	Automatic speed setting by Weight (%)
0	100
1	100
2	100
3 (Rated weight)	100
4	100
6	100
8	100

**2.4.3.5 Automatic acceleration/deceleration setting by Weight**

**LS4-C401S**

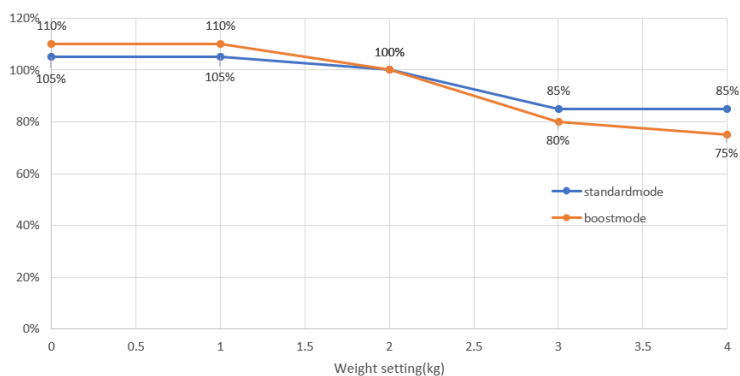

End effector weight (kg)	Automatic acceleration/deceleration setting by Weight	
	Standard mode	Boost mode
0	105	110
1	105	110
2 (Rated weight)	100	100

3	85	80
4	85	75

**LS8-C502S**

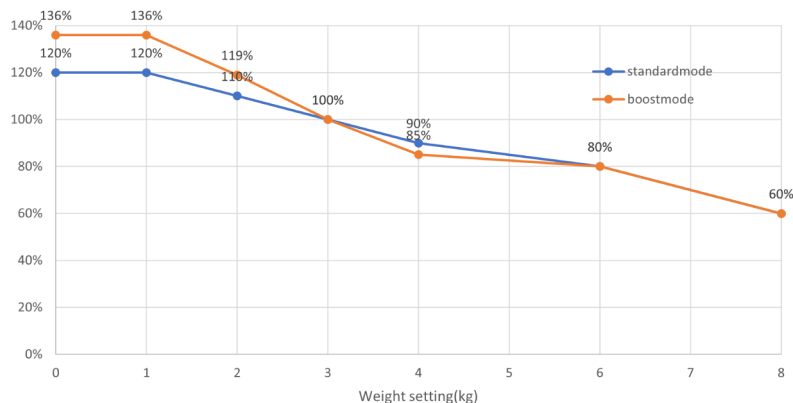

End effector weight (kg)	Automatic acceleration/deceleration setting by Weight	
	Standard mode	Boost mode
0	120	136
1	120	136
2	110	119
3 (Rated weight)	100	100
4	90	85
6	80	80
8	60	60

**LS8-C602S**

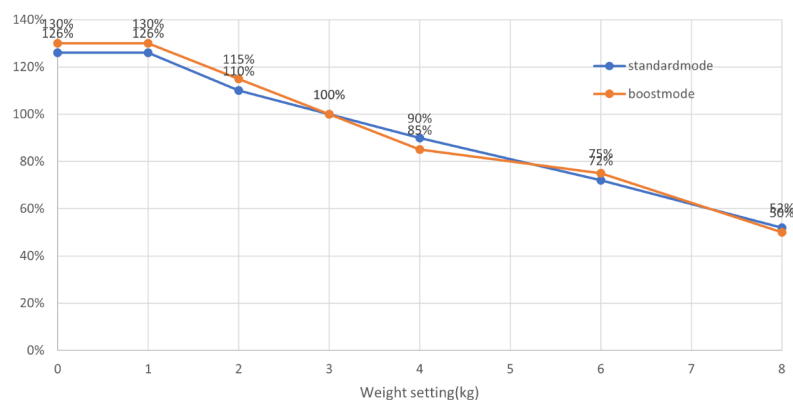

End effector weight (kg)	Automatic acceleration/deceleration setting by Weight	
	Standard mode	Boost mode
0	126	130
1	126	130

End effector weight (kg)	Automatic acceleration/deceleration setting by Weight	
	Standard mode	Boost mode
2	110	115
3 (Rated weight)	100	100
4	90	85
6	72	75
8	52	50

**LS8-C702S**

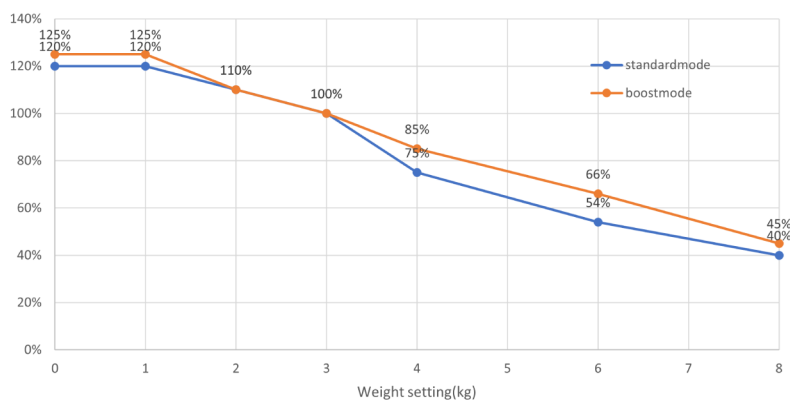

Hand weight (kg)	Automatic acceleration/deceleration setting by Weight	
	Standard mode	Boost mode
0	120	125
1	120	125
2	110	110
3 (Rated weight)	100	100
4	75	85
6	54	66
8	40	45

**2.4.3.6 Inertia Setting**

### 2.4.3.7 Moment of Inertia and the Inertia Setting

The moment of inertia is defined as “the ratio of the torque applied to a rigid body and its resistance to motion”. This value is typically referred to as “the moment of inertia”, “inertia”, or “GD2”. When the Manipulator operates with additional objects (such as an end effector) attached to the shaft, the moment of inertia of load must be considered.

#### CAUTION

The moment of inertia of the load (weight of the hand and workpiece) must be  $0.05 \text{ kg}\cdot\text{m}^2$  or less for LS4-C and  $0.12 \text{ kg}\cdot\text{m}^2$  or less for LS8-C. The LS50-C series are not designed to work with a moment of inertia exceeding  $0.05 \text{ kg}\cdot\text{m}^2$  for LS4-C and  $0.12 \text{ kg}\cdot\text{m}^2$  for LS8-C. Always set the value according to the moment of inertia. Setting a value that is smaller than the actual moment of inertia may cause errors, shock and insufficient function of the Manipulator. Also, the life cycle of parts may be shortened and positional gap due to belt tooth bumping may occur.

The acceptable moment of inertia of load for a LS-C series

- LS4-C: Rated:  $0.005 \text{ kg}\cdot\text{m}^2$  Maximum:  $0.05 \text{ kg}\cdot\text{m}^2$
- LS8-C: Rated:  $0.01 \text{ kg}\cdot\text{m}^2$  Maximum:  $0.12 \text{ kg}\cdot\text{m}^2$

If the moment of inertia of the load exceeds the rated weight, change the setting of the moment of inertia parameter of the Inertia command. After the setting is changed, the maximum acceleration/deceleration speed of Joint #4 at PTP motion corresponding to the “moment of inertia” value is set automatically.

### 2.4.3.8 Moment of inertia of load on the shaft

The moment of inertia of load (weight of the end effector and workpiece) on the shaft can be set by the “moment of inertia” parameter of the Inertia command.

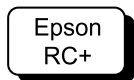

Enter a value into the [Moment of inertia] text box on the [Weight] panel ([Tools]-[Robot Manager]). (You may also execute the Inertia command from the [Command Window].)

### 2.4.3.9 Automatic acceleration/deceleration setting of Joint #4 by Inertia (moment of inertia)

**LS4-C401S**

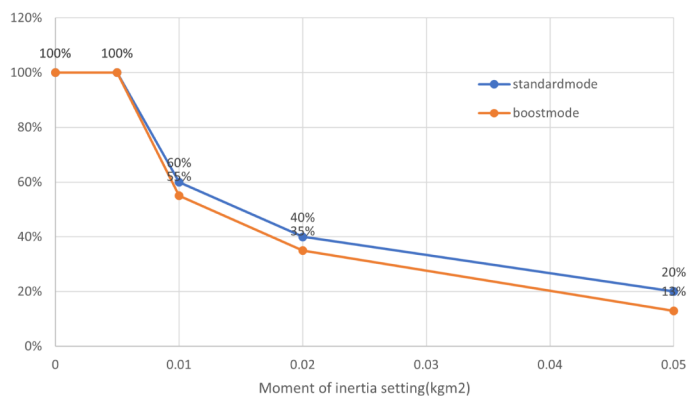

Moment of inertia setting parameter (kg·m <sup>2</sup> )	Automatic acceleration/deceleration (%) setting of Joint #4 by Inertia (moment of inertia)	
	standard mode	Boost mode
0	100	100
0.005 (Rated weight)	100	100
0.01	60	55
0.02	40	35
0.05	20	13

**LS8-C502S**

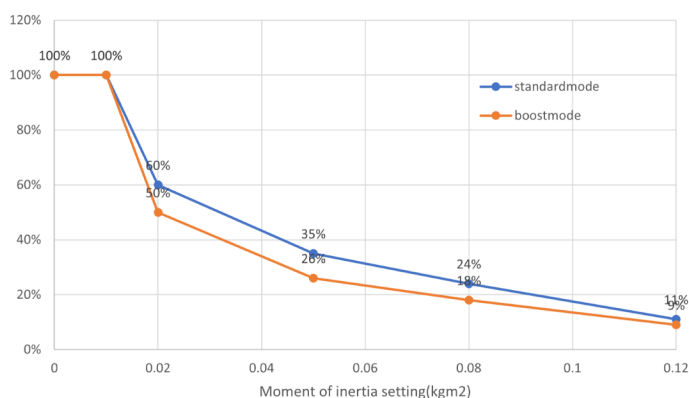

Moment of inertia setting parameter (kg·m <sup>2</sup> )	Automatic acceleration/deceleration (%) setting of Joint #4 by Inertia (moment of inertia)	
	standard mode	Boost mode
0	100	100
0.01 (Rated weight)	100	100
0.02	60	50
0.05	35	26
0.08	24	18
0.12	11	9

**LS8-C602S**

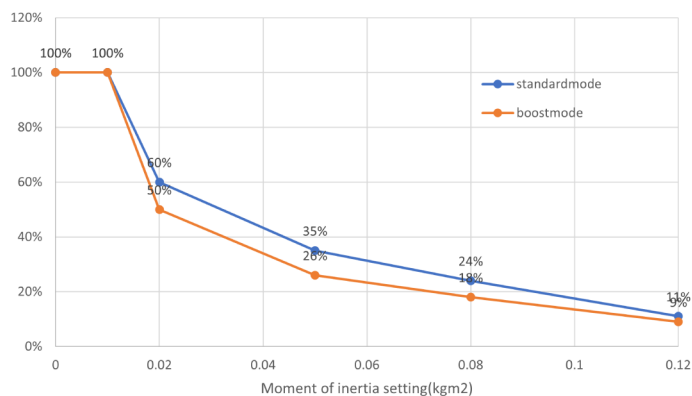

Moment of inertia setting parameter (kg·m <sup>2</sup> )	Automatic acceleration/deceleration (%) setting of Joint #4 by Inertia (moment of inertia)	
	standard mode	Boost mode
0	100	100
0.01 (Rated weight)	100	100
0.02	60	50
0.05	35	26
0.08	24	18
0.12	11	9

**LS8-C702S**

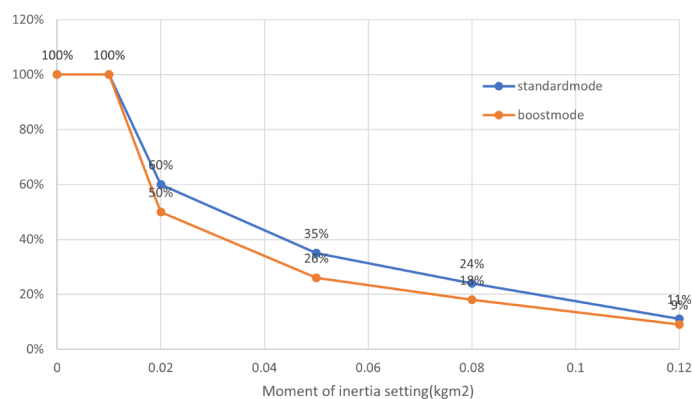

Moment of inertia setting parameter (kg·m <sup>2</sup> )	Automatic acceleration/deceleration (%) setting of Joint #4 by Inertia (moment of inertia)	
	standard mode	Boost mode
0	100	100
0.01 (Rated weight)	100	100
0.02	60	50
0.05	35	26
0.08	24	18
0.12	11	9

### 2.4.3.10 Eccentric Quantity and the Inertia Setting

**⚠ CAUTION**

- The eccentric quantity of the hand and workpiece must not exceed 150 mm for LS8-C and 100 mm for LS4-C. The LS-C series are not designed to work with eccentric quantity exceeding 150 mm for LS8-C and 100 mm for LS4-C. Always set the Weight parameters according to the load. Setting a value that is smaller than the actual load may cause errors, excessive shock and insufficient function of the Manipulator. Also, the life cycle of parts may be shortened and positional gap due to belt tooth bumping may occur.

The acceptable moment of inertia of load for a LS-C series

- LS4-C: Rated: 0 mm, Maximum: 100 mm
- LS8-C: Rated: 0 mm, Maximum: 150 mm

If the moment of inertia of the load exceeds the default rating, change the setting of eccentric quantity parameter of Inertia command. After the setting is changed, the maximum acceleration/deceleration speed of the Manipulator at PTP motion corresponding to the “eccentric quantity” is set automatically.

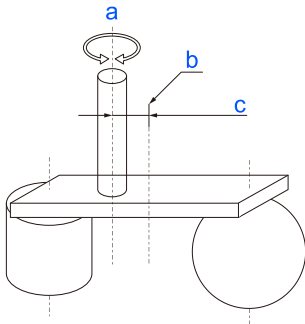

Symbol	Description
a	Rotation center
b	Position of load’s center of gravity
c	Eccentric quantity

### 2.4.3.11 Eccentric quantity of load on the shaft

The eccentric quantity of load (weight of the end effector and workpiece) on the shaft can be set by “eccentric quantity” parameter of Inertia command.

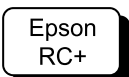

Enter a value into the [Eccentricity:] text box on the [Inertia] panel ([Tools]-[Robot Manager]). (You may also execute the Inertia command from the [Command Window].)

### 2.4.3.12 Automatic acceleration/deceleration setting by Inertia (eccentric quantity)

LS4-C401S

▪ **standard mode**

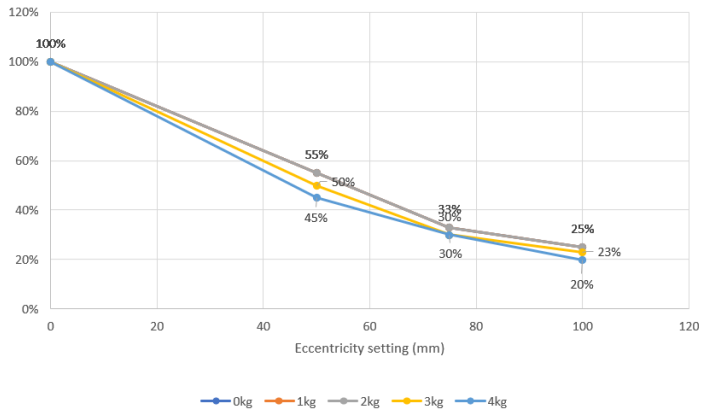

standard mode	Automatic acceleration/deceleration setting by Inertia (eccentric quantity) (%)			
	0	50	75	100
Eccentric quantity parameter (mm)				
0kg	100	55	33	25
1kg	100	55	33	25
2kg	100	55	33	25
3kg	100	50	30	23
4kg	100	45	30	20

▪ **Boost mode**

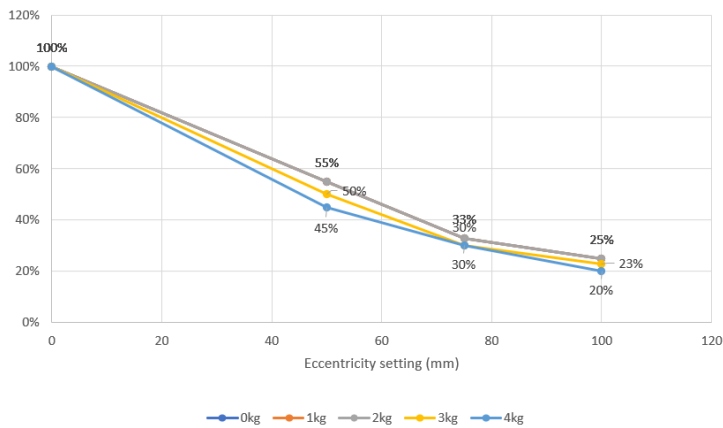

Boost mode	Automatic acceleration/deceleration setting by Inertia (eccentric quantity) (%)			
	0	50	75	100
Eccentric quantity parameter (mm)				
0kg	100	55	33	25
1kg	100	55	33	25
2kg	100	55	33	25

Boost mode	Automatic acceleration/deceleration setting by Inertia (eccentric quantity) (%)			
Eccentric quantity parameter (mm)	0	50	75	100
3kg	100	50	30	23
4kg	100	45	30	20

**LS8-C502S**

▪ **standard mode**

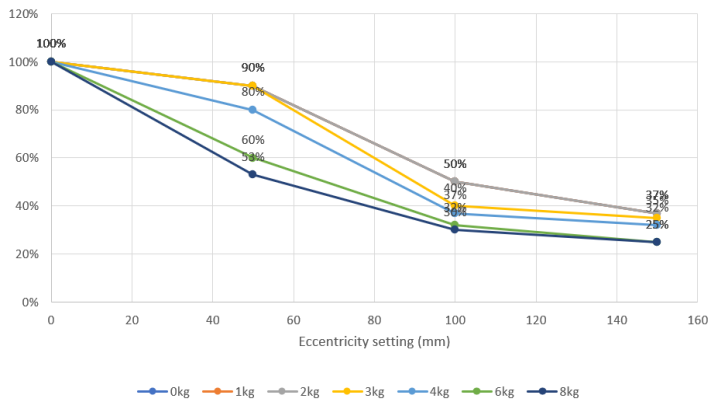

standard mode	Automatic acceleration/deceleration setting by Inertia (eccentric quantity) (%)			
Eccentric quantity parameter (mm)	0	50	100	150
0kg	100	90	50	37
1kg	100	90	50	37
2kg	100	90	50	37
3kg	100	90	40	35
4kg	100	80	37	32
6kg	100	60	32	25
8kg	100	53	30	25

▪ **Boost mode**

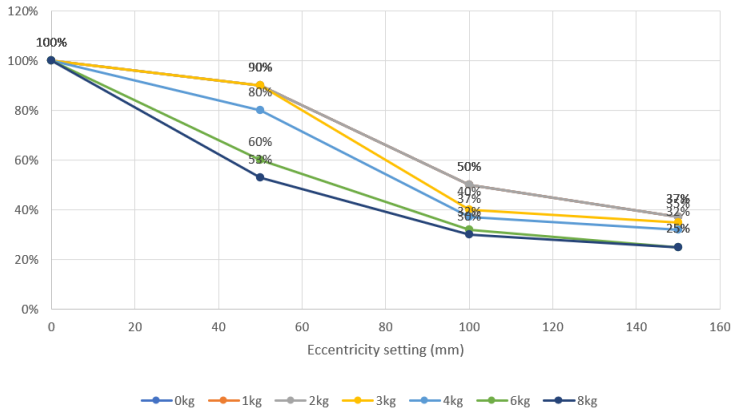

Boost mode	Automatic acceleration/deceleration setting by Inertia (eccentric quantity) (%)				
	Eccentric quantity parameter (mm)	0	50	100	150
0kg		100	90	50	37
1kg		100	90	50	37
2kg		100	90	50	37
3kg		100	90	40	35
4kg		100	80	37	32
6kg		100	60	32	25
8kg		100	53	30	25

**LS8-C602S**

▪ **standard mode**

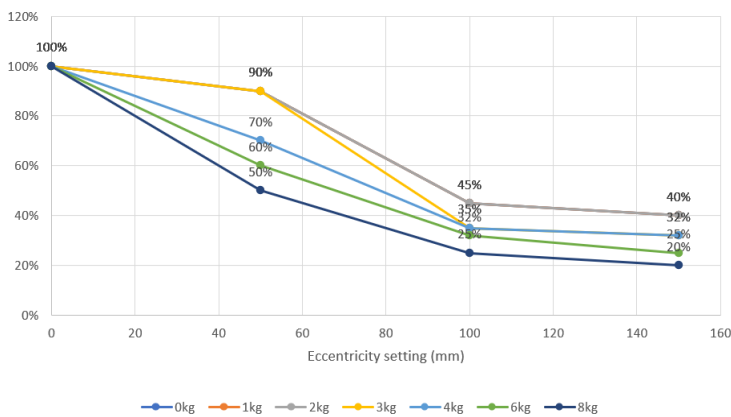

standard mode	Automatic acceleration/deceleration setting by Inertia (eccentric quantity) (%)				
	Eccentric quantity parameter (mm)	0	50	100	150
0kg		100	90	45	40

standard mode	Automatic acceleration/deceleration setting by Inertia (eccentric quantity) (%)			
Eccentric quantity parameter (mm)	0	50	100	150
1kg	100	90	45	40
2kg	100	90	45	40
3kg	100	90	35	32
4kg	100	70	35	32
6kg	100	60	32	25
8kg	100	50	25	20

▪ **Boost mode**

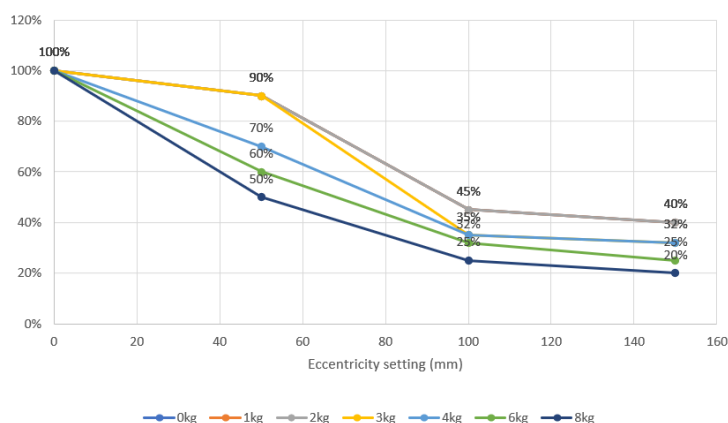

Boost mode	Automatic acceleration/deceleration setting by Inertia (eccentric quantity) (%)			
Eccentric quantity parameter (mm)	0	50	100	150
0kg	100	90	45	40
1kg	100	90	45	40
2kg	100	90	45	40
3kg	100	90	35	32
4kg	100	70	35	32
6kg	100	60	32	25
8kg	100	50	25	20

**LS8-C702S**

▪ **standard mode**

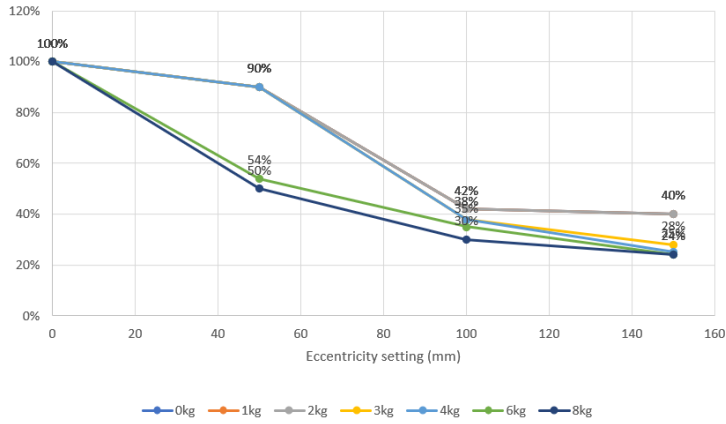

standard mode	Automatic acceleration/deceleration setting by Inertia (eccentric quantity) (%)				
	Eccentric quantity parameter (mm)	0	50	100	150
0kg		100	90	42	40
1kg		100	90	42	40
2kg		100	90	42	40
3kg		100	90	38	28
4kg		100	90	38	25
6kg		100	54	35	24
8kg		100	50	30	24

■ Boost mode

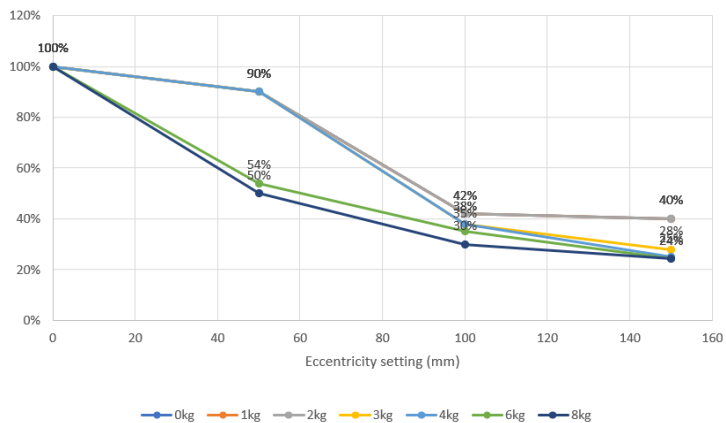

Boost mode	Automatic acceleration/deceleration setting by Inertia (eccentric quantity) (%)				
	Eccentric quantity parameter (mm)	0	50	100	150
0kg		100	90	42	40
1kg		100	90	42	40

2kg	100	90	42	40
3kg	100	90	38	28
4kg	100	90	38	25
6kg	100	54	35	24
8kg	100	50	30	24

### 2.4.3.13 Calculating the Moment of Inertia

Refer to the following examples of formulas to calculate the moment of inertia of load (end effector with workpiece). The moment of inertia of the entire load is calculated by the sum of each part (a), (b), and (c).

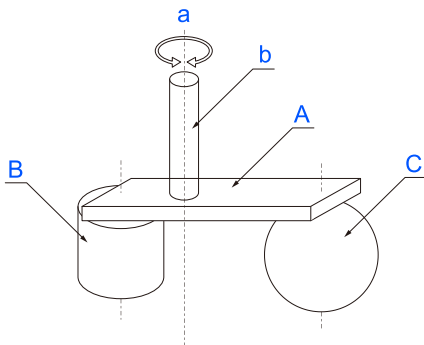

$$\text{Whole moment of inertia} = \text{Moment of inertia of end effector (A)} + \text{Moment of inertia of work piece (B)} + \text{Moment of inertia of work piece (C)}$$

Symbol	Description
a	End effector
b	Workpiece
c	Workpiece
d	Shaft
e	Rotation center

The methods for calculating the moment of inertia for (a), (b), and (c) are shown below. Calculate the total moment of inertia using the basic formulas.

#### (a) Moment of inertia of a rectangular parallelepiped

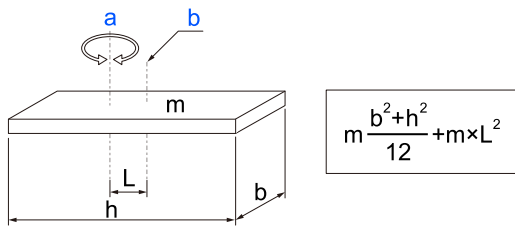

Symbol	Description
a	Rotation center
b	Rectangular parallelepiped's center of gravity

**(b) Moment of inertia of a cylinder**

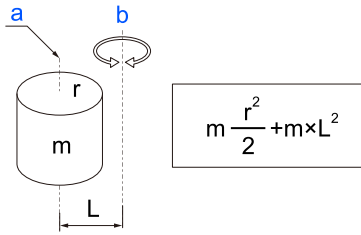

Symbol	Description
a	Cylinder's center of gravity
b	Rotation center

**(c) Moment of inertia of a sphere**

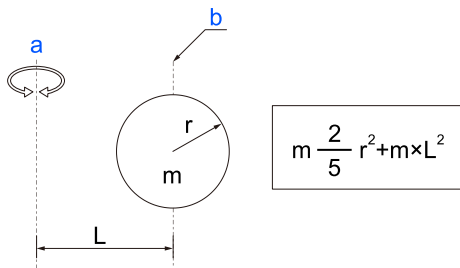

Symbol	Description
a	Rotation center
b	Sphere's center of gravity

**2.4.4 Precautions for Auto Acceleration/Deceleration of Joint #3**

When you move the Manipulator in horizontal PTP motion with Joint #3 (Z) at a high position, the motion time will be faster.

When Joint #3 gets below a certain point, then auto acceleration/deceleration is used to reduce acceleration/deceleration. (Refer to the figures below) The higher the position of the shaft is, the faster the motion acceleration/deceleration is. However, it takes more time to move Joint #3 up and down. Adjust the position of Joint #3 for the Manipulator motion after considering the relation between the current position and the destination position.

The upper limit of Joint #3 during horizontal motion using Jump command can be set by the LimZ command.

**2.4.4.1 Automatic acceleration/deceleration vs. Joint #3 position**

**LS4-C401S**

- standard mode

**KEY POINTS**

---

When moving the Manipulator horizontally while the shaft is being lowered, it may cause over-shoot at the time of final positioning.

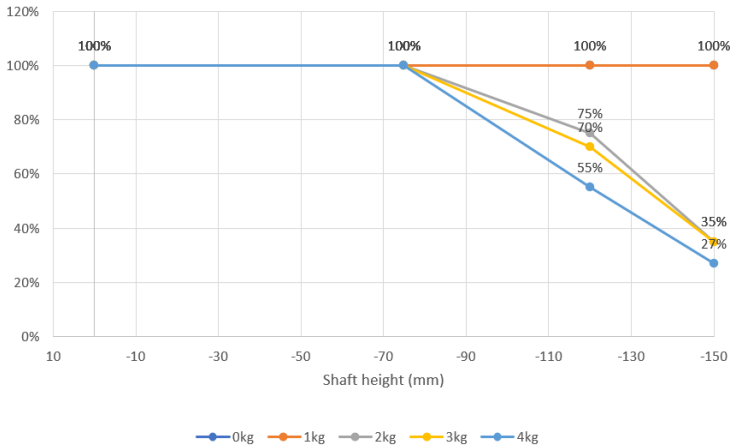

standard mode	Automatic acceleration/deceleration by the shaft position (%)			
Shaft height (mm)	0	-75	-120	-150
0 kg	100	100	100	100
1 kg	100	100	100	100
2 kg	100	100	75	35
3 kg	100	100	70	35
4 kg	100	100	55	27

■ **Boost mode**

**KEY POINTS**

When moving the Manipulator horizontally while the shaft is being lowered, it may cause over-shoot at the time of final positioning.

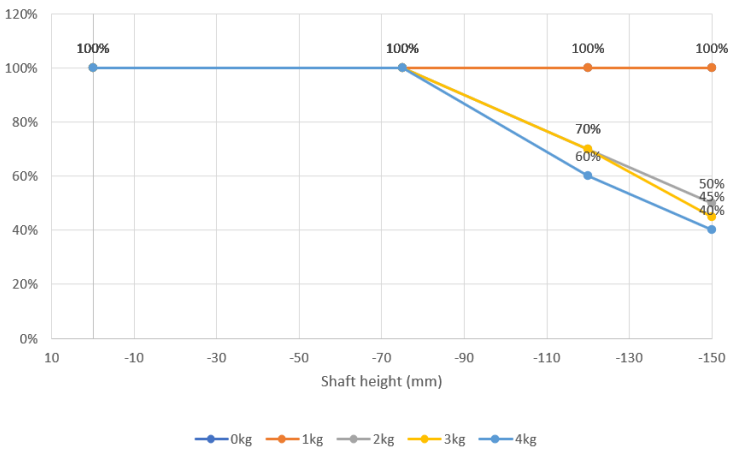

Boost mode	Automatic acceleration/deceleration by the shaft position (%)			
Shaft height (mm)	0	-75	-120	-150
0kg	100	100	100	100

Boost mode	Automatic acceleration/deceleration by the shaft position (%)			
Shaft height (mm)	0	-75	-120	-150
1kg	100	100	100	100
2kg	100	100	70	50
3kg	100	100	70	45
4kg	100	100	60	40

**LS8-C502S**

▪ **standard mode**

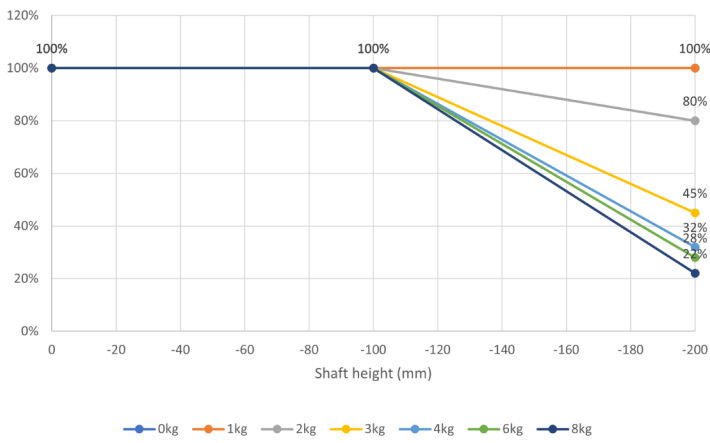

**KEY POINTS**

When moving the Manipulator horizontally while the shaft is being lowered, it may cause over-shoot at the time of final positioning.

standard mode	Automatic acceleration/deceleration by the shaft position (%)		
Shaft height (mm)	0	-100	-200
0 kg	100	100	100
1 kg	100	100	100
2 kg	100	100	80
3 kg	100	100	45
4 kg	100	100	32
6 kg	100	100	28
8 kg	100	100	22

▪ **Boost mode**

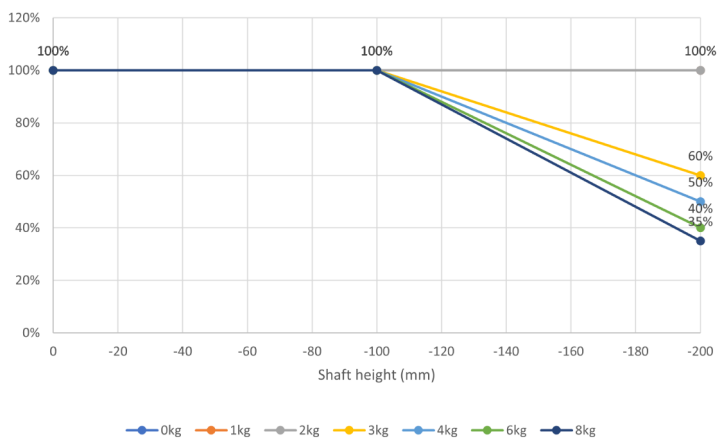

### KEY POINTS

When moving the Manipulator horizontally while the shaft is being lowered, it may cause over-shoot at the time of final positioning.

Boost mode	Automatic acceleration/deceleration by the shaft position (%)		
Shaft height (mm)	0	-100	-200
0 kg	100	100	100
1 kg	100	100	100
2 kg	100	100	100
3 kg	100	100	60
4 kg	100	100	50
6 kg	100	100	40
8 kg	100	100	35

### LS8-C602S

#### standard mode

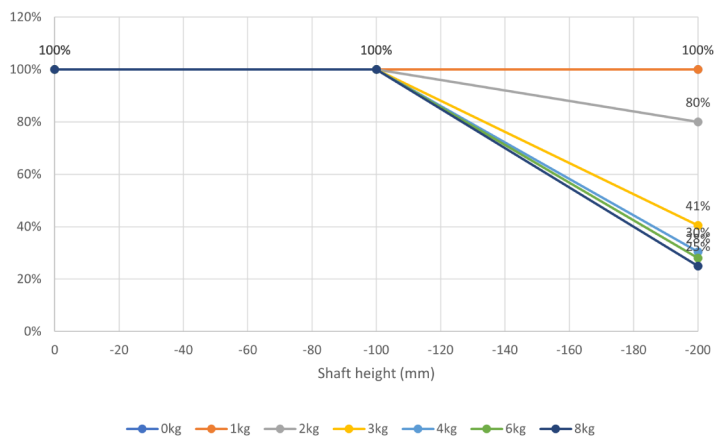

**KEY POINTS**

When moving the Manipulator horizontally while the shaft is being lowered, it may cause over-shoot at the time of final positioning.

standard mode	Automatic acceleration/deceleration by the shaft position (%)		
Shaft height (mm)	0	-100	-200
0 kg	100	100	100
1 kg	100	100	100
2 kg	100	100	80
3 kg	100	100	41
4 kg	100	100	30
6 kg	100	100	28
8 kg	100	100	25

■ **Boost mode**

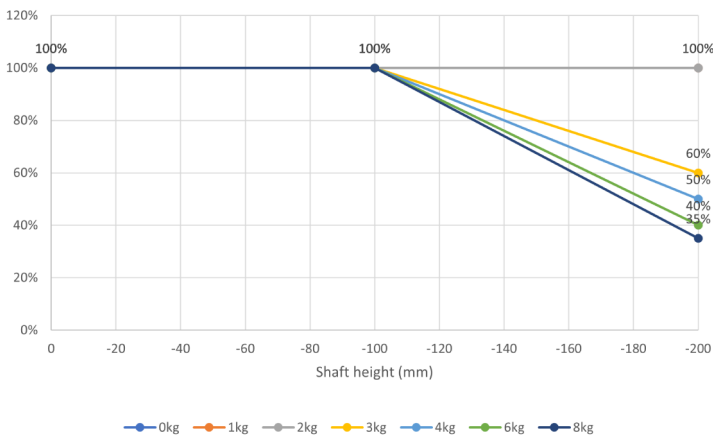

**KEY POINTS**

When moving the Manipulator horizontally while the shaft is being lowered, it may cause over-shoot at the time of final positioning.

Boost mode	Automatic acceleration/deceleration by the shaft position (%)		
Shaft height (mm)	0	-100	-200
0 kg	100	100	100
1 kg	100	100	100
2 kg	100	100	100
3 kg	100	100	60
4 kg	100	100	50

Boost mode	Automatic acceleration/deceleration by the shaft position (%)		
Shaft height (mm)	0	-100	-200
6 kg	100	100	40
8 kg	100	100	35

**LS8-C702S**

▪ **standard mode**

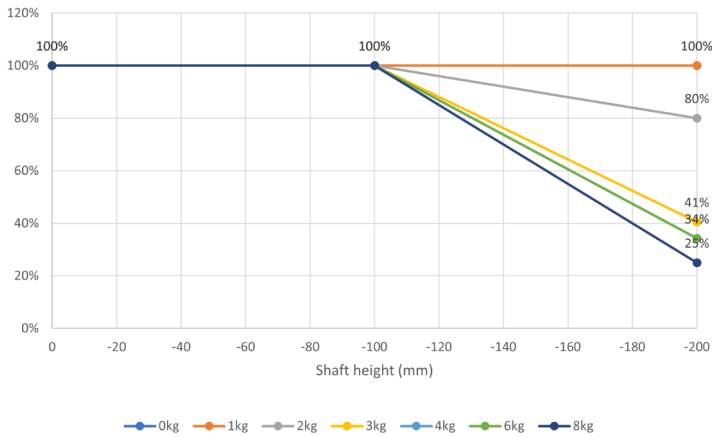

**KEY POINTS**

When moving the Manipulator horizontally while the shaft is being lowered, it may cause over-shoot at the time of final positioning.

standard mode	Automatic acceleration/deceleration by the shaft position (%)		
Shaft height (mm)	0	-100	-200
0 kg	100	100	100
1 kg	100	100	100
2 kg	100	100	80
3 kg	100	100	41
4 kg	100	100	34
6 kg	100	100	34
8 kg	100	100	25

▪ **Boost mode**

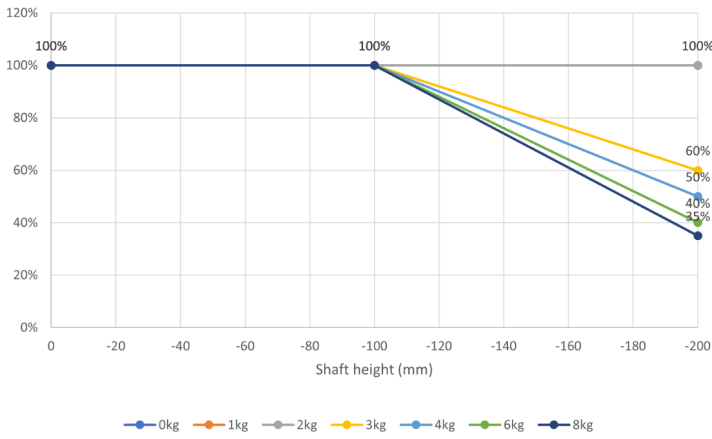

**KEY POINTS**

When moving the Manipulator horizontally while the shaft is being lowered, it may cause over-shoot at the time of final positioning.

Boost mode	Automatic acceleration/deceleration by the shaft position (%)		
	0	-100	-200
Shaft height (mm)			
0 kg	100	100	100
1 kg	100	100	100
2 kg	100	100	100
3 kg	100	100	60
4 kg	100	100	50
6 kg	100	100	40
8 kg	100	100	35

## 2.5 Motion Range

**CAUTION**

When setting up the motion range for safety, both the pulse range and mechanical stops must always be set at the same time.

The motion range is preset at the factory as explained in the following section.

### Standard Motion Range

This is the maximum motion range of the Manipulator.

There are three methods for setting the motion range described as follows:

1. Setting by pulse range (for all joints)
2. Setting by mechanical stops (for Joints #1 to #3)
3. Setting the Cartesian (rectangular) range in the X, Y coordinate system of the Manipulator (for Joints #1 and #2)

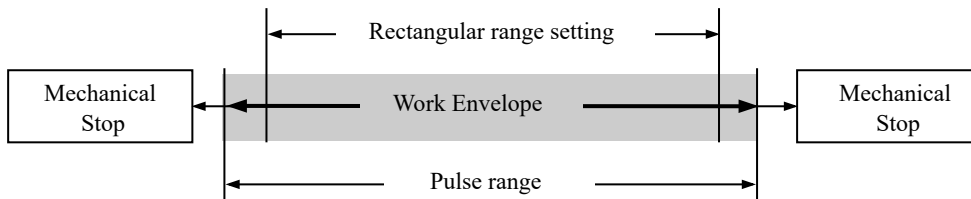

When the motion range is changed due to layout efficiency or safety, follow the descriptions below.

- [Motion Range Setting by Pulse Range](#)
- [Setting the Cartesian \(Rectangular\) Range in the XY Coordinate System of the Manipulator](#)

## 2.5.1 Motion Range Setting by Pulse Range

Pulses are the basic unit of Manipulator motion. The motion range of the Manipulator is controlled by the pulse range between the pulse lower limit and upper limit of each joint. Pulse values are read from the encoder output of the servo motor.

For the maximum pulse range, refer to the following sections. The pulse range must be set inside of the mechanical stop range.

- [Max. Pulse Range of Joint #1](#)
- [Max. Pulse Range of Joint #2](#)
- [Max. Pulse Range of Joint #3](#)
- [Max. Pulse Range of Joint #4](#)

### KEY POINTS

Once the Manipulator receives an operating command, it checks whether the target position specified by the command is within the pulse range before operating. If the target position is out of the set pulse range, an error occurs and the Manipulator does not move.

Epson  
RC+

The pulse range can be set on the [Range] panel shown by selecting [Tools]-[Robot Manager]. (You may also execute the Range command from the [Command Window].)

### 2.5.1.1 Max. Pulse Range of Joint #1

The 0 (zero) pulse position of Joint #1 is the position where Arm #1 faces toward the positive (+) direction on the X-coordinate axis. With the 0 pulse as a starting point, the counterclockwise pulse value is defined as the positive (+) and the clockwise pulse value is defined as the negative (-).

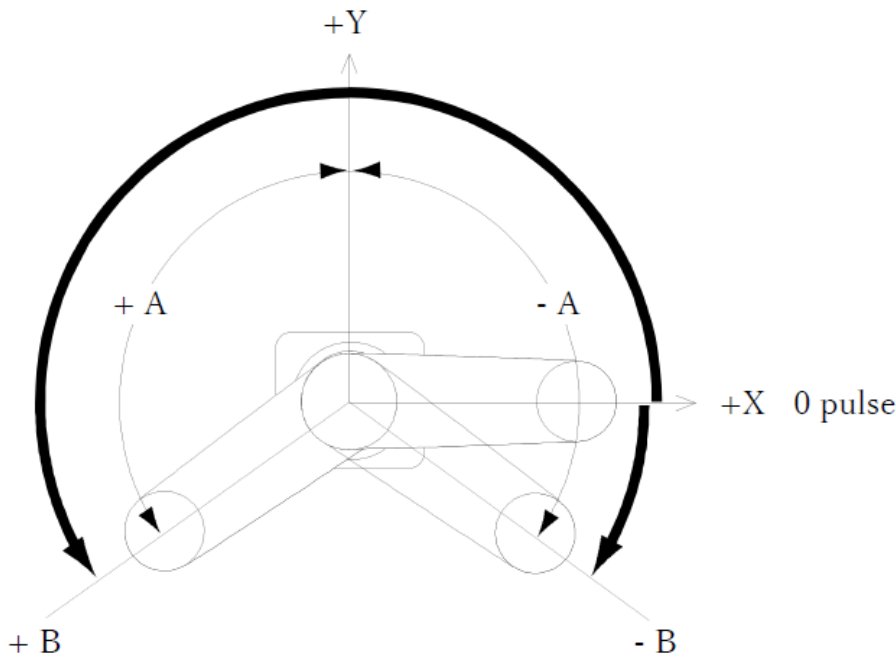

	A: Max. Motion Range	B: Max. Pulse Range
LS4-C	±132°	- 95574 to 505174 pulse
LS8-C		- 152918 to 808278 pulse

### 2.5.1.2 Max. Pulse Range of Joint #2

The 0 (zero) pulse position of Joint #2 is the position where Arm #2 is in-line with Arm #1. (Same for all direction of Arm #1)  
 With the 0 pulse as a starting point, the counterclockwise pulse value is defined as the positive (+) and the clockwise pulse value is defined as the negative (-).

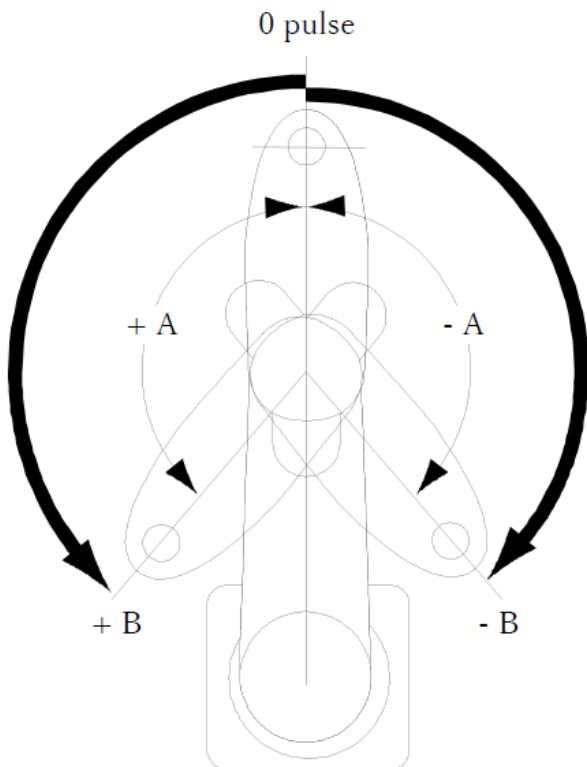

	A: Max. Motion Range	B: Max. Pulse Range
LS4-C	±141°	±320854 pulse
LS8-C	±150°	±341334 pulse

### 2.5.1.3 Max. Pulse Range of Joint #3

The 0 (zero) pulse position of Joint #3 is the position where the shaft is at its upper limit. The pulse value is always negative because Joint #3 always moves lower than the 0 pulse position.

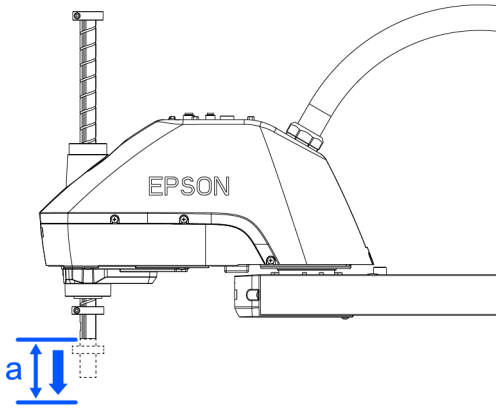

Symbol	Description
a	Upper limit: 0 pulse

	Joint #3 stroke	Lower Limit Pulse
LS4-C401S (Standard specification)	-150 to 0 mm	-187734 pulse
LS4-C401C (Cleanroom + ESD)	-120 to 0 mm	-150187 pulse
LS8-C*02S (Standard specification)	-200 to 0 mm	-273067 pulse
LS8-C*02C (Cleanroom + ESD)	-170 to 0 mm	-232107 pulse

**KEY POINTS**

The motion area setting cannot be changed by the Joint #3 mechanical stop for the cleanroom environment specification Manipulator.

### 2.5.1.4 Max. Pulse Range of Joint #4

The 0 (zero) pulse position of Joint #4 is the position where the flat near the end of the shaft faces toward the end of Arm #2. (Same for all directions of Arm #2) With the 0 pulse as a starting point, the counterclockwise pulse value is defined as the positive (+) and the clockwise pulse value is defined as the negative (-).

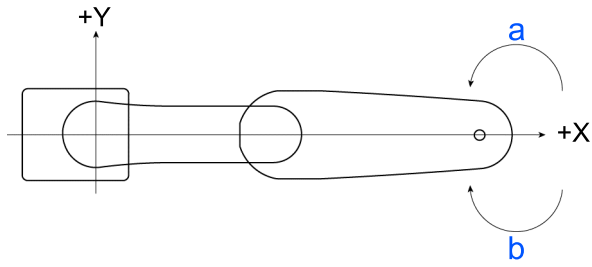

Symbol	Description
a	+ direction
b	- direction

	A: Max. Motion Range	B: Max. Pulse Range
LS4-C	±360° *	0±165376 pulse
LS8-C		0±245761 pulse

\*The J4 motion range ±360 can be changed.

## 2.5.2 Motion Range Setting by Mechanical Stops

Mechanical stops physically limit the absolute area that the Manipulator can move.

Both Joints #1 and #2 have threaded holes in positions corresponding to angles for the setting area. Set the motion range depending on the position of the mechanical stop (adjustable) Install the bolts in the holes corresponding to the angle that you want to set.

Joints #3 can be set to any length less than the maximum stroke.

The motion area setting cannot be changed by the Joint #3 mechanical stop for the cleanroom environment specification Manipulator.

Symbol	Description
a	Mechanical stop of Joint #3 (Lower limit mechanical stop)
b	Mechanical stop of Joint #3 (Upper limit mechanical stop): Do not move the position.
c	Mechanical stop of Joint #2 (Adjustable)
d	Mechanical stop of Joint #1 (Adjustable)
e	Mechanical stop of Joint #1 (Fixed)
f	Mechanical stop of Joint #2 (Fixed)

### 2.5.2.1 Setting the Mechanical Stops of Joints #1 and #2

Both Joints #1 and #2 have threaded holes in positions corresponding to angles for the setting area. Set the motion range depending on the position of the mechanical stop (adjustable) Install the bolts in the holes corresponding to the angle that you want to set.

Install the bolts for the mechanical stop to the following position.

**Joint #1 Mechanical Stops**

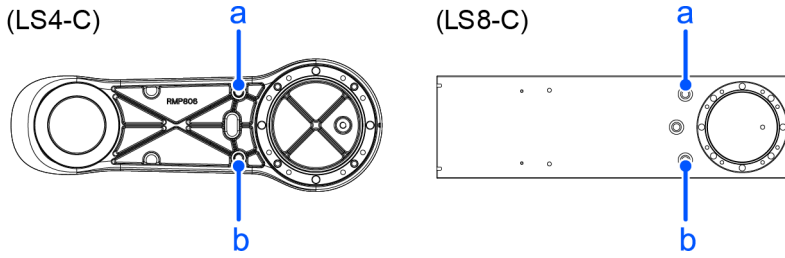

This is a figure of Arm #1 viewed from below.

		a	b
LS4-C	Setting Angle (°)	110	-110
	Pulse Value (pulse)	455111	-45511
LS8-C	Setting Angle (°)	115	-115
	Pulse Value (pulse)	746382	-91022

**Joint #2 Mechanical Stops**

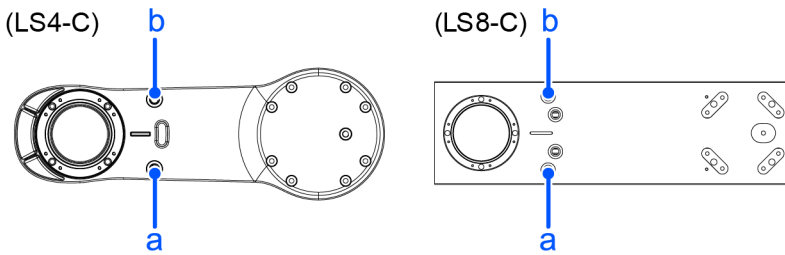

This is a figure of Arm #1 viewed from above.

		a	b
LS4-C/ LS8-C	Setting Angle (°)	125	-125
	Pulse Value (pulse)	284444	-284444

1. Turn off the Controller.
2. Install a hexagon socket head cap bolt into the hole corresponding to the setting angle, and tighten it.

Models	Joint	Hexagon socket head cap bolt	The number of bolts	Recommended tightening torque	Strength
LS4-C	1 & 2	M8×10 full thread	1 bolt / side	13.0 N · m (132.7 kgfcm)	ISO898-1 property class 10.9 or 12.9.
LS8-C	1 & 2	M10×35 full thread	1 bolt / side	13.0 N · m (132.7 kgfcm)	ISO898-1 property class 10.9 or 12.9.

3. Turn on the Controller.
4. Set the pulse range corresponding to the new positions of the mechanical stops.

Be sure to set the pulse range inside the positions of the mechanical stop range.

[Example: Using LS8-C602S to set Joint #1 from -110° to +110° and Joint #2 from -110° to +110°]



Execute the following commands from the [Command Window].

```
>JRANGE 1, -72817, 728177 ' Sets the pulse range of Joint #1
>JRANGE 2, -250311, 250311 ' Sets the pulse range of Joint #2
>RANGE ' Checks the set value using Range command
-72817, 728177, -250311, 250311, -245760 ,0, -245760, 245760
```

5. Move the arm by hand until it touches the mechanical stops, and make sure that the arm does not hit any peripheral equipment during operation.
6. Operate the joint changed at low speeds until it reaches the positions of the minimum and maximum pulse range. Make sure that the arm does not hit the mechanical stops.

(Check the position of the mechanical stop and the motion range you set.)

[Example: Using LS8-C602S to set Joint #1 from -110° to +110° and Joint #2 from -110° to +110°]



Execute the following commands from the [Command Window].

```
>MOTOR ON ' Turns On the motor
>POWER LOW ' Enters low-power mode
>SPEED 5 ' Sets at low speed
>PULSE 1, -72817.0, 0.0 ' Moves to the min. pulse position of Joint #1
>PULSE 72817,0,0,0 ' Moves to the max. pulse position of Joint #1
>PULSE 327680,-250311,0,0 ' Moves to the min. pulse position of Joint #2
```

```
PULSE 327680,250311,0,0 ' Moves to the max. pulse position of Joint #2 ``
```

The Pulse command (Go Pulse command) moves all joints to the specified positions at the same time. Specify safe positions after considering motion of not only the joints whose pulse range have been changed, but also other joints.

In this example, when checking Joint #2, the Joint #1 setting is set to 0°; which is near the center of the motion area. (The pulse value is "327680" for LS4-C and "204800" for LS8-C)

If the arm is hitting the mechanical stops or if an error occurs after the arm hits the mechanical stops, either reset the pulse range to a narrower setting or extend the positions of the mechanical stops within the limit.

### 2.5.2.2 Setting the Mechanical Stops of Joints #3

This methods only applies to standard environment specification Manipulators. The motion area setting cannot be changed by the Joint #3 mechanical stop for the cleanroom environment specification Manipulator.

1. Turn ON the Controller and turn OFF the motors using the Motor OFF command.
2. Push up the shaft while pressing the brake release switch.

Do not push the shaft up to its upper limit or it will be difficult for the arm top cover to be removed. Push the shaft up to a position where the Joint #3 mechanical stop can be changed.

When you press the brake release switch, the shaft may lower due to the weight of the hand. Be sure to hold the shaft by hand while pressing the button.

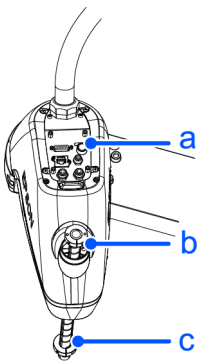

Symbol	Description
a	Brake release switch
b	Lower limit mechanical stop mounting screw: M4×15
c	Shaft

3. Turn off the Controller.

4. Loosen the lower limit mechanical stop screw (M4× 15).

A mechanical stop is mounted on both the top and bottom of Joint #3. However, only the position of the lower limit mechanical stop on the top can be changed. Do not remove the upper limit mechanical stop on the bottom because the calibration point of Joint #3 is specified using the stop.

5. The upper end of the shaft defines the maximum stroke. Move the lower limit mechanical stop down by the length you want to limit the stroke.

For example, when the lower limit mechanical stop is set at “200 mm” stroke, the lower limit Z coordinate value is “-200”. To change the value to “-180”, move the lower limit mechanical stop down “20 mm”. Use calipers to measure the distance when adjusting the mechanical stop.

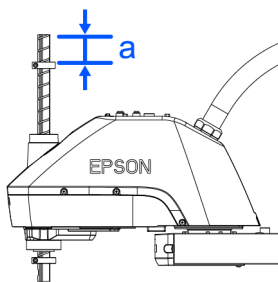

Symbol	Description
a	Measurement length

6. Firmly tighten the lower limit mechanical stop screw (M4×15).

Recommended tightening torque: 5.4 N m (55 kgf cm)

7. Turn ON the Controller.

8. Move Joint #3 to its lower limit while pressing the brake release switch, and then check the lower limit position. Do not lower the mechanical stop too far. Otherwise, the joint may not reach a target position.
9. Calculate the lower limit pulse value of the pulse range using the formula shown below and set the value.

The result of the calculation is always negative because the lower limit Z coordinate value is negative.

Lower limit of pulse (pulse) = lower limit Z coordinate value (mm) / Joint #3 Resolution\*\* (mm/pulse)

\*\* For Joint #3 resolution, refer to the following.

### Appendix B: Specification Table

Epson  
RC+

Execute the following commands from the [Command Window]. Enter the calculated value in X.

```
>JRANGE 3,X,0      '      Sets the pulse range of Joint #3
```

10. Using the Pulse command (Go Pulse command), move Joint #3 to the lower limit position of the pulse range at low speed.

If the mechanical stop range is less than the pulse range, Joint #3 will hit the mechanical stop and an error will occur. When the error occurs, either change the pulse range to a lower setting or extend the position of the mechanical stop within the limit.

If it is difficult to check whether Joint #3 hits a mechanical stop, turn OFF the Controller and lift the arm top cover to check the condition causing the problem from the side.

Epson  
RC+

Execute the following commands from the [Command Window]. Enter the value calculated in Step (9) in X.

```
>MOTOR ON      '      Turns On the motor
>SPEED 5       '      Sets at low speed
>PULSE 0,0,X,0      '      Operate at the lower limit pulse position of Joint
#3 (In this example, all pulses except those for Joint #3 are "0". Substitute
these "0s" with the other pulse values specifying a position where there is no
interference even when lowering Joint #3.)
```

## 2.5.3 Setting the Cartesian (Rectangular) Range in the XY Coordinate System of the Manipulator

(for Joints #1 and #2)

Use this method to set the upper and lower limits of the X and Y coordinates.

This setting is only enforced by software. Therefore, it does not change the physical range. The maximum physical range is based on the position of the mechanical stops.

Epson  
RC+

Set the XYLim setting on the [XYZ Limits] panel shown by selecting [Tools]-[Robot Manager]. (You may also execute the XYLim command from the [Command Window].)

## 2.5.4 Standard Motion Range

### Motion Range

The following “motion range” diagrams show the standard (maximum) specification. When each Joint motor is under servo control, the center of Joint #3’s (shaft’s) lowest point moves in the areas shown in the figure.

### Area limited by a mechanical stop

The area where the center of Joint #3’s lowest point can be moved when each joint motor is not under servo control.

### Mechanical stop

The area that contains the farthest reach of the arms.

### Maximum Range

The area that contains the farthest reach of the arms. If the maximum radius of the end effector is over 60 mm, add the “Area limited by mechanical stop” and “radius of the end effector” as the maximum area.

A	Center of Joint #3
B	Motion Range
C	Maximum Range
D	Base mounting face
E	Area limited by a mechanical stop

		LS4- C401 *	LS8- C502 *	LS8- C602 *	LS8- C702*
a	Arm #1 + Arm #2 [mm]	400	500	600	700
b	Arm 1 length [mm]	225	225	325	425
c	Arm 2 length [mm]	175	275		
d	Joint #1 motion range [°]	132	132		
e	Joint #2 motion range [°]	141	150		
f	(Motion range)	141.6	138.1	162.6	232
g	(Motion range of the back side)	325.5	425.6	492.5	559.4
h	Angle to the mechanical stop of Joint #1 [°]	1.5	1.5		
i	Angle to the mechanical stop of Joint #2 [°]	4.3	5.1		
j	(Mechanical stop area)	128.5	118.3	138.3	210.3
k	(Mechanical stop area on the back side)	329.9	429.9	408.7	567.6
m	(Joint #3 motion range)	Standard model	150	200	
		Cleanroom specification	120	170	

			LS4-C401 *	LS8-C502 *	LS8-C602 *	LS8-C702*
n	(Distance from the base mounting face)	Standard model	5.5	51		
		Cleanroom specification	9.5	53		
p	(Joint #3 mechanical stop area, upper terminal)	Standard model	6.5	10		
		Cleanroom specification	10.5	6		
q	(Joint #3 mechanical stop area, lower terminal)	Standard model	9.3	13		
		Cleanroom specification	3.8	11		

**Standard environment specification**

**LS4-C401S**

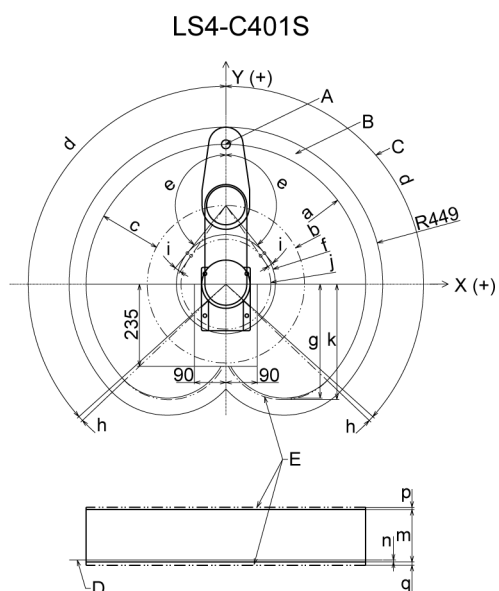

**Cleanroom Environment Specification**

**LS4-C401C**

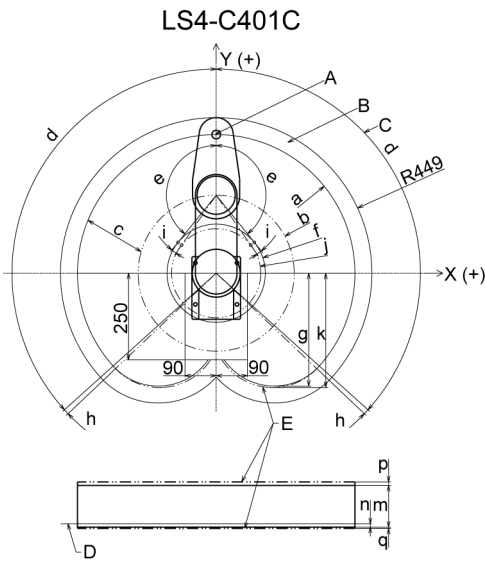

**Standard environment specification**

**LS8-C\*02S**

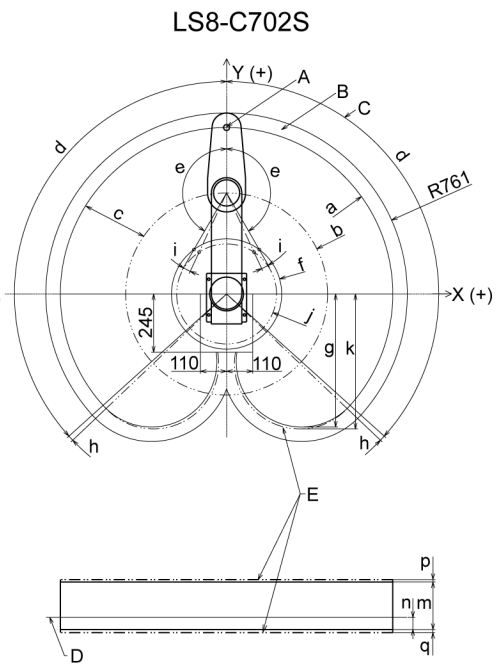
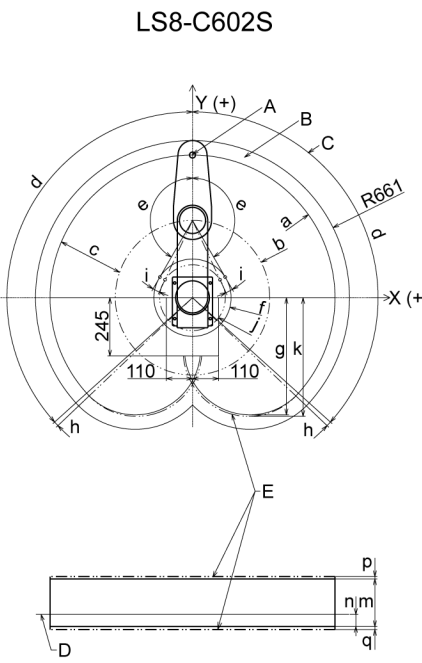
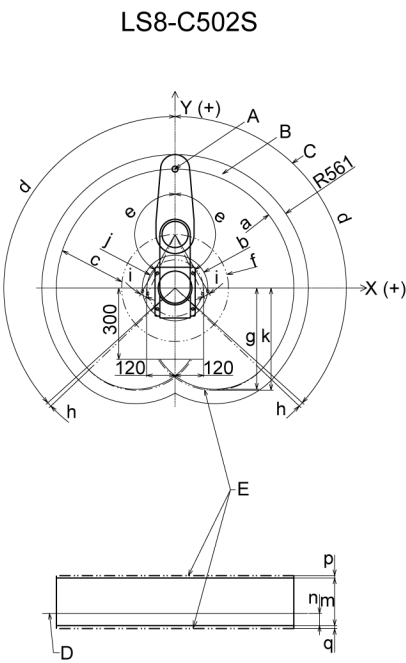

**Cleanroom Environment Specification**

**LS8-C\*02C**

LS8-C502C

LS8-C602C

LS8-C702C

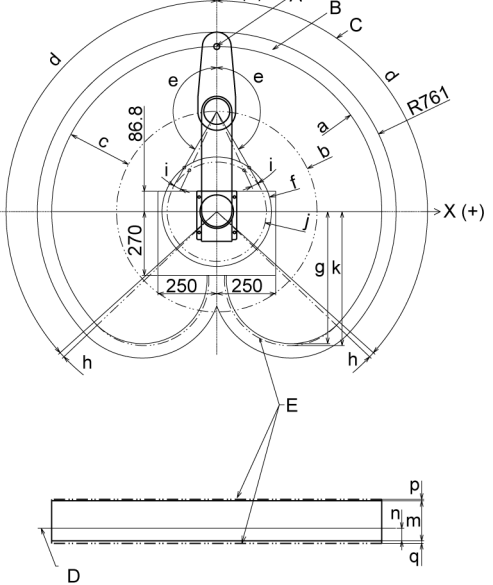
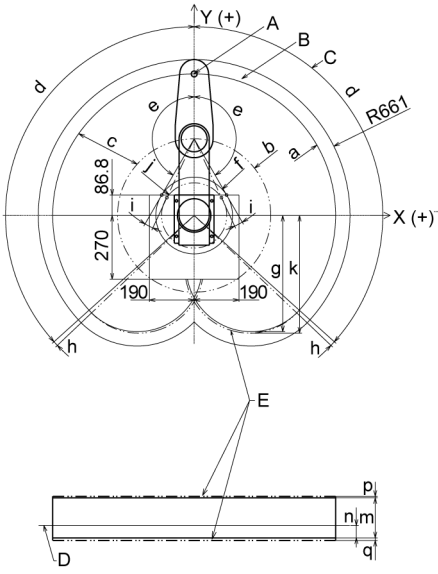
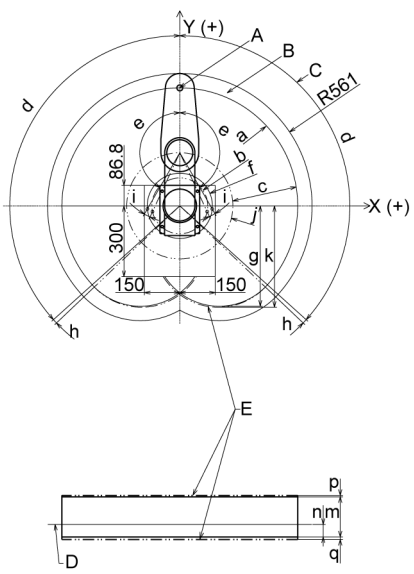

## **3. LS20-C Manipulator**

This volume contains information for setup and operation of the Manipulators.

Please read this volume thoroughly before setting up and operating the Manipulators.

## 3.1 Safety

The Manipulator and its related equipment should be unpacked and transported by people who have received installation training provided by Epson and the suppliers. Also, the laws and regulations of the installation country must be followed.

Before use, please read this manual and other related manuals to ensure correct use. After reading this manual, store it in an easily accessible location for future reference.

This product is intended for transporting and assembling parts in a safely isolated area.

### 3.1.1 Conventions

The following symbols are used in this manual to indicate important safety information. Be sure to read the descriptions shown with each symbol.

#### WARNING

This symbol indicates an imminently hazardous situation which, if operation is not performed properly, will result in death or serious injury.

#### WARNING

This symbol indicates a potentially hazardous situation which, if operation is not performed properly, could result in an injury due to electric shock.

#### CAUTION

This symbol indicates a potentially hazardous situation which, if operation is not performed properly, may result in a minor or moderate injury or in property damage only.

### 3.1.2 Design and Installation Safety

This product is intended for transporting and assembling parts in a safely isolated area.

Design and installation of robot system shall be performed by personnel who has taken robot system training held by us and suppliers.

To ensure safety, a safeguard must be installed for the robot system. For details on the safeguard, refer to the following.

#### Safeguard

The following items are safety precautions for design personnel.

#### WARNING

- Personnel who design and/or construct the robot system with this product must read the “Safety Manual” to understand the safety requirements before designing and/or constructing the robot system. Designing and/or constructing the robot system without understanding the safety requirements is extremely hazardous, may

result in serious bodily injury and/or severe equipment damage to the robot system, and may cause serious safety problems.

- The Manipulator and the Controller must be used within the environmental conditions described in their respective manuals. This product has been designed and manufactured strictly for use in a normal indoor environment. Using the product in an environment that exceeds the specified environmental conditions may not only shorten the life cycle of the product but may also cause serious safety problems.
- The robot system must be used within the installation requirements described in the manuals. Using the robot system outside of the installation requirements may not only shorten the life cycle of the product but also cause serious safety problems.
- When designing or installing a robot system, wear at least the following protective gear. Working without protective gear may cause serious safety problems.
  - Work clothes suitable for work
  - Helmet
  - Safety shoes

Further precautions for installation are mentioned in the following.

**Environment and Installation**

Please read this chapter carefully to understand safe installation procedures before installing the robots and robotic equipment.

**3.1.2.1 Strength of the Ball Screw Spline**

If a load exceeding the allowable value is applied to the ball screw spline, it may not work properly due to deformation or breakage of the shaft.

If the ball screw spline is applied the load exceeding the allowable value, it is necessary to replace the ball screw spline unit. The allowable loads differ depending on distance where the load is applied to. For calculating the allowable load, see the calculation formula below.

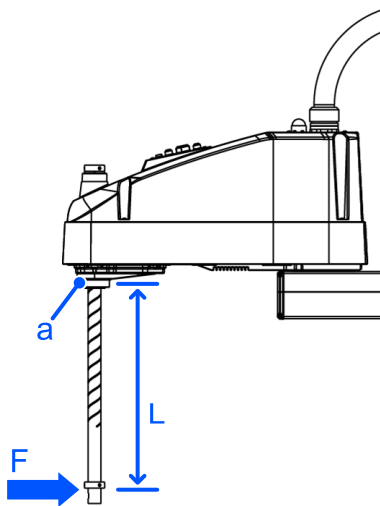

Symbol	Description
a	End of the spline nut

**Example:**

If 110 N (11.2kgf) load is applied at 400 mm from the end of the spline nut

**Allowable bending moment**

$M=50,000 \text{ N}\cdot\text{mm}$

### Moment

$M=F\cdot L = 100\cdot 400 = 44,000 \text{ N}\cdot\text{mm}$

## 3.1.3 Operation Safety

The following items are safety precautions for qualified Operator personnel:

### WARNING

- Please carefully read the Safety Requirements in the “Safety Manual” before operating the robot system. Operating the robot system without understanding the safety requirements is extremely hazardous and may result in serious bodily injury and/or severe equipment damage to the robot system.
- Do not enter the operating area of the Manipulator while the power to the robot system is turned ON. Entering the operating area with the power ON is extremely hazardous and may cause serious safety problems as the Manipulator may move even if it seems to be stopped.
- Before operating the robot system, make sure that no one is inside the safeguarded area. The robot system can be operated in the mode for teaching even when someone is inside the safeguarded area. The motion of the Manipulator is always in restricted (low speed and low power) status to secure the safety of an operator. However, operating the robot system while someone is inside the safeguarded area is extremely hazardous and may result in serious safety problems in case that the Manipulator moves unexpectedly.
- Immediately press the Emergency Stop switch whenever the Manipulator moves abnormally while the robot system is operated. Continuing the operation while the Manipulator moves abnormally is extremely hazardous and may result in serious bodily injury and/or severe equipment damage to the robot system.

### WARNING

- To shut off power to the robot system, disconnect the power plug from the power source or use a disconnecter. Be sure to connect the AC power cable to either a power receptacle or a disconnecter. DO NOT connect it directly to a factory power source.
- Before performing any replacement procedure, turn OFF the Controller and related equipment, and then disconnect the power plug from the power source. Performing any replacement procedure with the power ON is extremely hazardous and may result in electric shock and/or malfunction of the robot system.
- Do not connect or disconnect the motor connectors while the power to the robot system is turned ON. Connecting or disconnecting the motor connectors with the power ON is extremely hazardous and may result in serious bodily injury as the Manipulator may move abnormally. Performing any work procedure with the power turned on is extremely dangerous and may result in electric shock and/or malfunction of the robot system.

### CAUTION

- Whenever possible, only one person should operate the robot system. If it is necessary to operate the robot system with more than one person, ensure that all people involved communicate with each other as to what they are doing and take all necessary safety precautions.
- Joint #1, #2, and #4: If the joints are operated repeatedly with the operating angle less than 5 degrees, the bearings are likely to cause oil film shortage in such situation. Repeating the operation may cause the

Manipulator to break faster. To prevent early breakdown, move each joint larger than 50 degrees for about once an hour.

- Joint #3: If the up-and-down motion of the hand is less than 50 mm, move the joint a half of the maximum stroke for about once an hour.
- Vibration (resonance) may occur continuously in low speed Manipulator motion (Speed: approx. 5 to 20%) depending on combination of Arm orientation and end effector load. Vibration arises from natural vibration frequency of the Arm and can be controlled by following measures.
  - Changing Manipulator speed
  - Changing the teach points
  - Changing the end effector load

### 3.1.4 Emergency Stop

Each robot system needs equipment that will allow the operator to immediately stop the system's operation. Install an emergency stop device by using emergency stop input from the Controller or other equipment.

Before using the emergency stop switch, be aware of the following points.

- The emergency stop switch should be used to stop the Manipulator only in case of emergencies.
- Besides pressing the emergency stop switch when an emergency occurs, to stop the Manipulator during program operation, use the Pause or STOP (program stop) statements assigned to a standard I/O.  
The Pause and STOP statements do not turn off motor energization, and so the brake is not locked.

To place the robot system in emergency stop mode in a non-emergency (normal) situation, press the emergency stop switch while the Manipulator is not operating.

Do not press the emergency stop switch unnecessarily while the Manipulator is operating normally.

It could shorten the lifespan of the following components.

- Brakes  
The brakes will be locked, which will shorten the lifespan of the brakes due to worn brake friction plates.
  - Normal brake lifespan:  
About 2 years (when the brakes are used 100 times/day)  
or about 20,000 times
- Reduction gears  
An emergency stop applies an impact to the reduction gear, which can shorten its life.

If the Manipulator is stopped by turning off the Controller while it is operating, the following problems may occur.

- Reduced life and damage to reduction gear
- Position shift at the joints

If a power outage or other unavoidable Controller power-off occurs during Manipulator operation, check the following points after power is restored.

- Damage in reduction gear
- Shifting of the joints from their proper positions

If there was any shifting, maintenance is required. For more information, please contact the supplier.

#### Stopping distance of emergency stop

The Manipulator during operation cannot stop immediately after the emergency stop switch is pressed. Also, the stopping time and movement distance vary depending on the following factors.

- Hand weight, WEIGHT setting, ACCEL setting, workpiece weight, SPEED setting, movement posture, etc.

For the stopping time and movement distance of the Manipulator, refer to the following section.

### Appendix C: Stopping time and Stopping distance in Emergency

## 3.1.5 Safeguard

To maintain a safe working zone, safety barriers must be set up around the Manipulator, and safeguards must be installed at the entrance and exit of the safety barriers.

The term "safeguard" as used in this manual refers to a safety device with an interlock that allows entry into the safety barriers. Specifically, this includes safety door switches, safety barriers, light curtains, safety gates, safety floor mats, and so on. The safeguard is an input that informs the Robot Controller that an operator may be inside the safeguard area. You must assign at least one Safeguard (SG) in Safety Function Manager.

When the safeguard is opened, Protective Stop operates to change to the safeguard open state (display: SO).

- Safeguard open  
Operations are prohibited. Further robot operation is not possible until either the safeguard is closed, the latched state is released, and a command is executed, or the TEACH or TEST operation mode is turned on and the enable circuit is activated.
- Safeguard closed  
The robot can operate automatically in an unrestricted (high power) state.

### WARNING

- If a third party accidentally releases the safeguard while an operator is working inside the safety barriers, this may result in a hazardous situation. To protect the operator working inside the safety barriers, implement measures to lock out or tag out the latch release switch.
- To protect operators working near the robot, be sure to connect a safeguard switch and make sure that it works properly.

### Installing safety barriers

When installing safety barriers within the maximum range of the Manipulator, combine safety functions such as SLP. Carefully take into account the size of the hand and the workpieces to be held so that no interference occurs between the operating parts and the safety barriers.

### Installing safeguards

Design the safeguards so that they satisfy the following requirements:

- When using a key switch type safety device, use a switch that forcibly opens the interlock contacts. Do not use switches that open their contacts using the spring force of the interlock.
- When using an interlock mechanism, do not disable the interlock mechanism.

### Considering the stopping distance

During operation, the Manipulator cannot stop immediately even if the safeguard is opened. Also, the stopping time and movement distance vary depending on the following factors.

- Hand weight, WEIGHT setting, ACCEL setting, workpiece weight, SPEED setting, movement posture, etc.

For the stopping time and movement distance of the Manipulator, refer to the following section.

**Appendix D: Stopping time and Stopping distance when Safeguard is Opened**

**Precautions for safeguard operation**

Do not open the safeguard unnecessarily while the motor is energized. Frequent safeguard inputs will reduce the life of the relay.

- Normal relay lifespan: Approximately 20,000 times

**3.1.6 Emergency Movement without Drive Power**

When the system is placed in emergency mode, push the arm or joint of the Manipulator by hand as shown below:

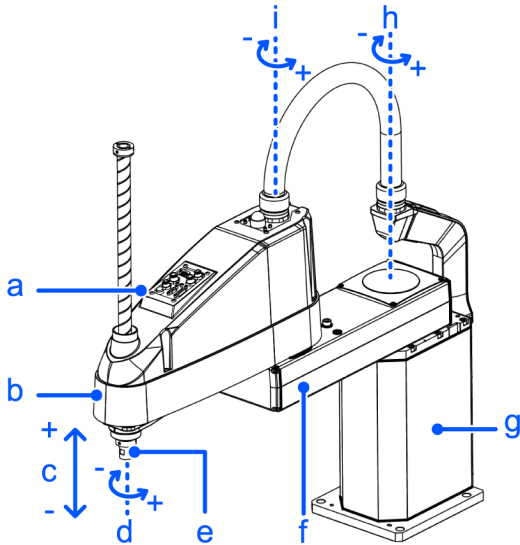

(Figure: LS20-C804S)

Symbol	Description
a	Joint #3 #4 Brake release switch
b	Arm #2
c	Joint #3 (up and down)
d	Joint #4 (rotating)
e	Shaft
f	Arm #1
g	Base
h	Joint #1 (rotating)
i	Joint #2 (rotating)

- Arm #1: Push the arm by hand.
- Arm #2: Push the arm by hand.
- Joint #3: The joint cannot be moved up/down by hand until the electromagnetic brake applied to the joint has been released. Move the joint up/down while pressing the brake release switch.
- Joint #4: The shaft cannot be rotated by hand until the electromagnetic brake applied to the shaft has been released. Move the joint up/down while pressing the brake release switch.

**KEY POINTS**

The brake release switch affects both Joints #3 and #4. When the brake release switch is pressed in emergency mode, the brake for both Joints #3 and #4 are released simultaneously. Be careful of the shaft falling and rotating due to hand weight while the brake release switch is being pressed.

**3.1.7 ACCELS Setting for CP Motions**

To make the Manipulator move in a CP motion, make the appropriate ACCELS settings in the SPEL program based on the tip load and Z-axis height.

**KEY POINTS**

If the ACCELS settings are not properly configured, the following problem occurs.

- Shortened lifespan and damage to the ball screw spline
- Stop with error (Error code: 4002)

Set ACCELS as shown below based on the Z-axis height.

**Maximum ACCELS correction values by Z-axis height and tip load**

Z-axis height(mm)	Tip load			
	5kg or less	10kg or less	15kg or less	20kg or less
0>Z≥-100	10000 or less	10000 or less	10000 or less	9000 or less
-100>Z≥-200			7000 or less	5500 or less
-200>Z≥-300		7500 or less	5000 or less	3500 or less
-300>Z≥-420		5500 or less	3500 or less	2500 or less

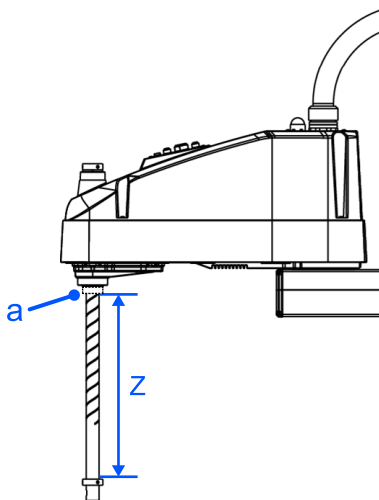

Symbol	Description
a	Z-axis height 0 (Origin position)

If the Manipulator is operated in CP motion with the wrong set values, make sure to check the following.

- Whether or not the ball screw spline shaft is deformed or bent

### 3.1.8 Warning Labels

The Manipulator has the following warning labels. Specific hazards exist in the vicinity of areas with the warning labels. Be thoroughly careful in handling. To ensure that the Manipulator is operated and maintained safely, be sure to follow the safety information and warnings indicated on the warning labels. Also, do not tear, damage, or remove these warning labels.

A



Touching any internal electrified parts while the power is turned on may cause electric shock.

B



The surface of the Manipulator is very hot during and after operation which can cause for you to get burnt.

1

This indicates the product name, model name, serial number, information of supported laws and regulations, product specifications, manufacturer, importer, date of manufacture, country of manufacture, and the like.

For details, see the label affixed to the product.

2



Indicates the position of the brake release switch

3



Indicates the position of a threaded hole for an eye bolt mounting screw.

LS20-C

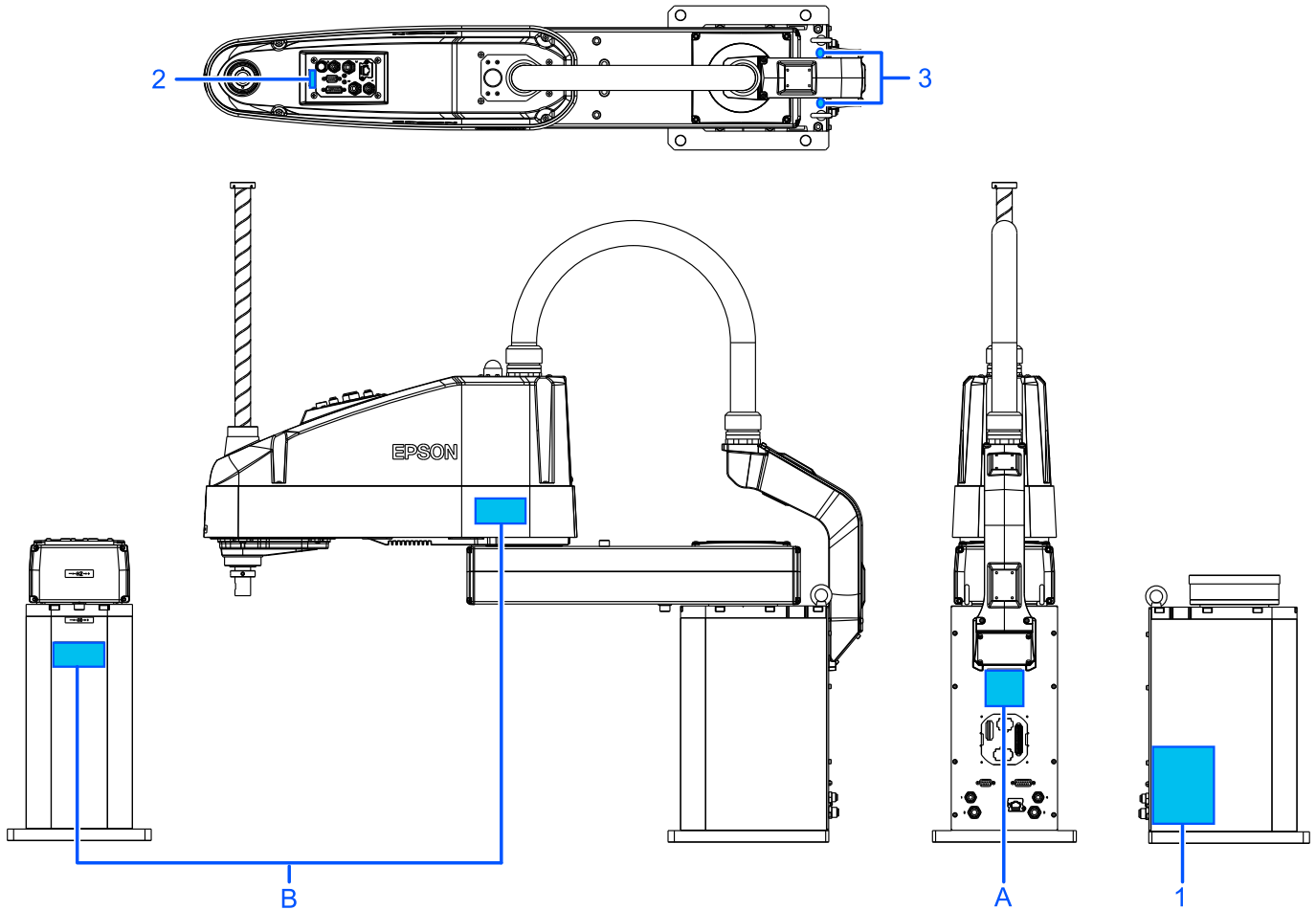

**3.1.9 Response for Emergency or Malfunction**

**3.1.9.1 Collision**

If the Manipulator has collided with a mechanical stop, peripheral device, or other object, discontinue use and contact the supplier.

Also, if the Manipulator collides with mechanical stops or peripheral devices, the following problems may occur.

- Reduction of the life and damage of the reduction gear unit
- Position gap at the joints

**3.1.9.2 Getting body caught in Manipulator**

When the operator is caught between the Manipulator and a mechanical part such as a base table, press the emergency stop switch to release the brake on the subject arm, and then move the arm by hand.

- Get body caught in the arms:

The break is not working. Move the arms manually.

- Get body caught in the shafts:

The break is working. Press the brake release switch and move the shafts.

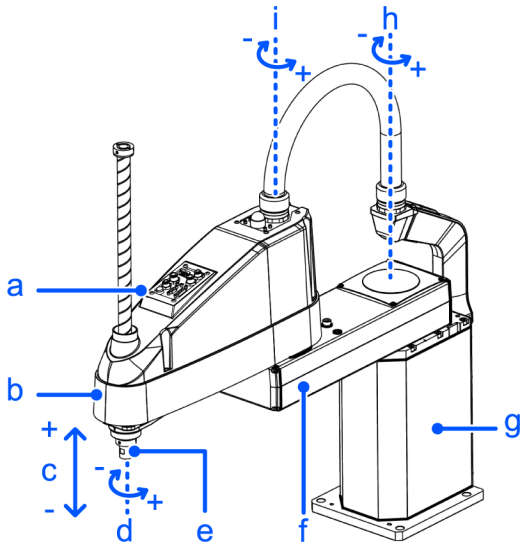

(Figure: LS20-C804S)

Symbol	Description
a	Joint #3 #4 Brake release switch
b	Arm #2
c	Joint #3 (up and down)
d	Joint #4 (rotating)
e	Shaft
f	Arm #1
g	Base
h	Joint #1 (rotating)
i	Joint #2 (rotating)

**⚠ CAUTION**

Both Joint #3 and #4 may move due to its own weight while the brake release switch is pressed. Be careful of the shaft falling and rotating.

## 3.2 Specification

### 3.2.1 Model number

LS20-C80 4 S

[a]
[b]
[c]
[d]

- a: Payload
  - 20: 20 kg
- b: Arm length
  - 80: 800 mm
  - A0: 1000 mm
- c: Joint #3 stroke
  - 4: 420 mm (Standard environment specification)/390 mm (Cleanroom environment specification (bellows included))
- D: Environment
  - S: Standard
  - C: Cleanroom

#### About the Environment

##### Cleanroom Environment Specification

The cleanroom environment specification Manipulator is a product that is based on the standard environment specification reduces dust emission from the Manipulator so that it can be used in the cleanroom.

For details on the specifications, refer to the following.

#### Appendix B: Specification Table

##### List of Models

Payload	Arm length	Environment	Joint #3 stroke	Model number
20 kg	800 mm	Standard	420 mm	LS20-C804S
		Cleanroom	390 mm	LS20-C804C
	1000 mm	Standard	420 mm	LS20-CA04S
		Cleanroom	390 mm	LS20-CA04C

### 3.2.2 Part Names and Outer Dimensions

### 3.2.2.1 Standard environment specification (LS20-C\*\*4S)

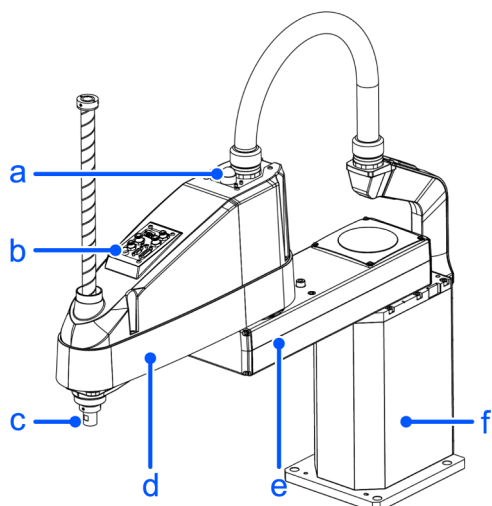

Symbol	Description
a	LED lamp
b	Joint #4 Brake release switch
c	Shaft
d	Arm #2
e	Arm #1
f	Base

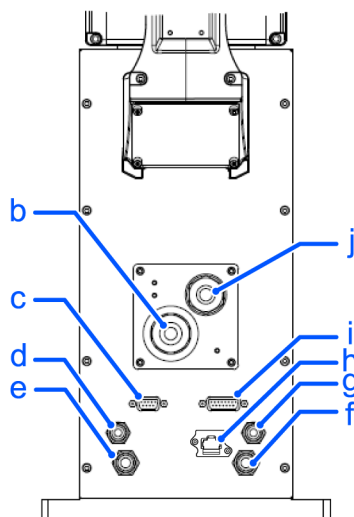
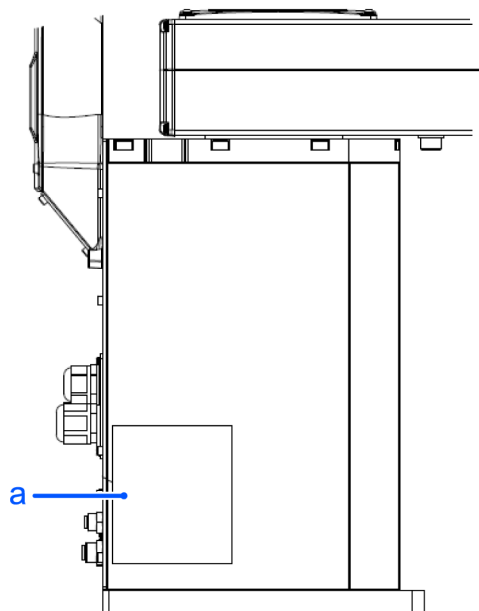

Symbol	Description
a	Signature label (Serial No. of Manipulator)
b	Power cable
c	User connector (9-pin D-sub connector)
d	Fittings for ø6 mm pneumatic tube (No.1)

Symbol	Description
e	Fittings for ø8 mm pneumatic tube (No.2)
f	Fittings for ø8 mm pneumatic tube (No.3)
g	Fittings for ø6 mm pneumatic tube (No.4)
h	Ethernet connector
i	User connector (15-pin D-sub connector)
j	Signal Cable

### KEY POINTS

- The brake release switch affects both Joints #3 and #4. When the brake release switch is pressed in emergency mode, the brake for both Joints #3 and #4 are released simultaneously.
- While the LED lamp is on, current is being applied to the Manipulator. Performing any work with the power ON is extremely hazardous and may result in electric shock and/or malfunction of the robot system. Make sure to turn OFF the controller power before maintenance work.

**LS20-C\*\*4S (Standard Environment Specification)**

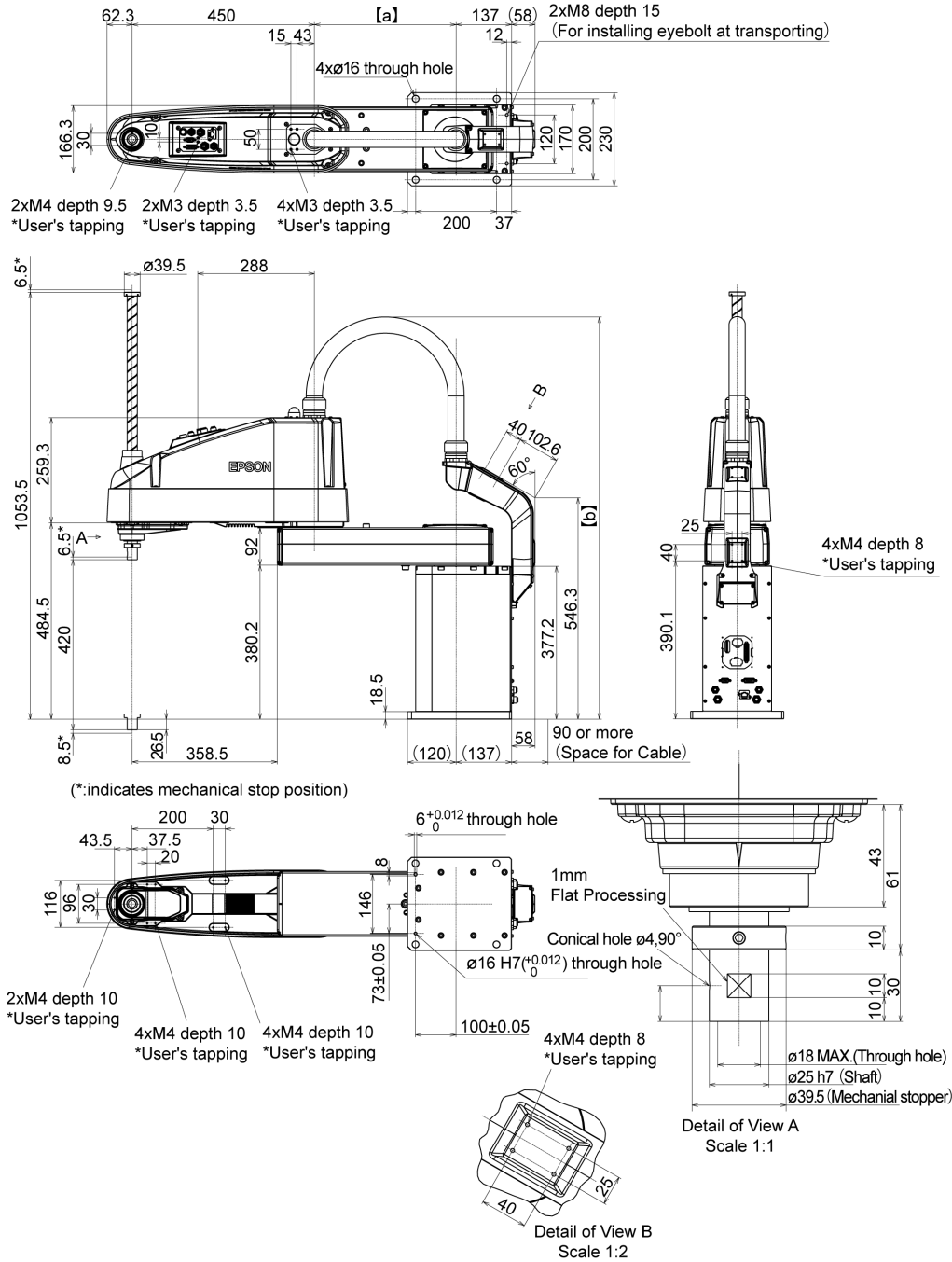

	LS20-C804S	LS20-CA04S
a	350	550
b	MAX. 1000	MAX. 1100

### 3.2.2.2 Cleanroom Standard Environment Specification (LS20-C\*\*4C)

The appearance of the cleanroom environment specification differs from the standard environment specification in the following parts:

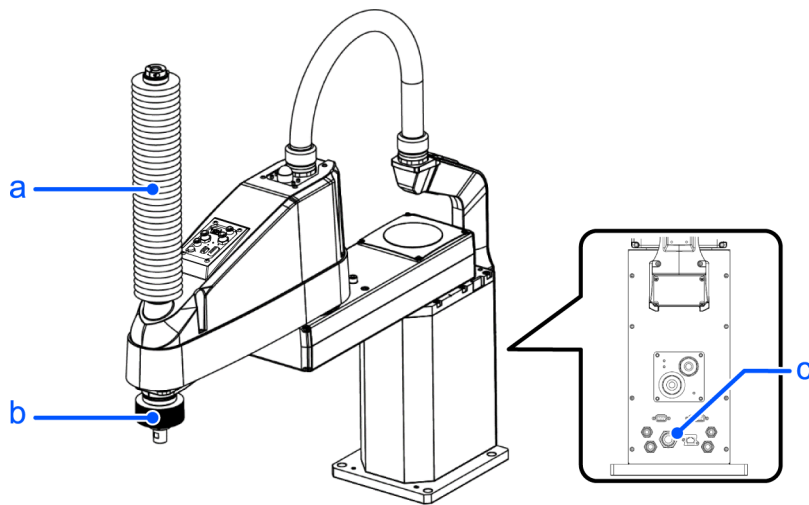

Symbol	Description
a	Upper bellows
b	Lower bellows
c	Exhaust port

**Cleanroom Standard Environment Specification (LS20-C\*\*4C)**

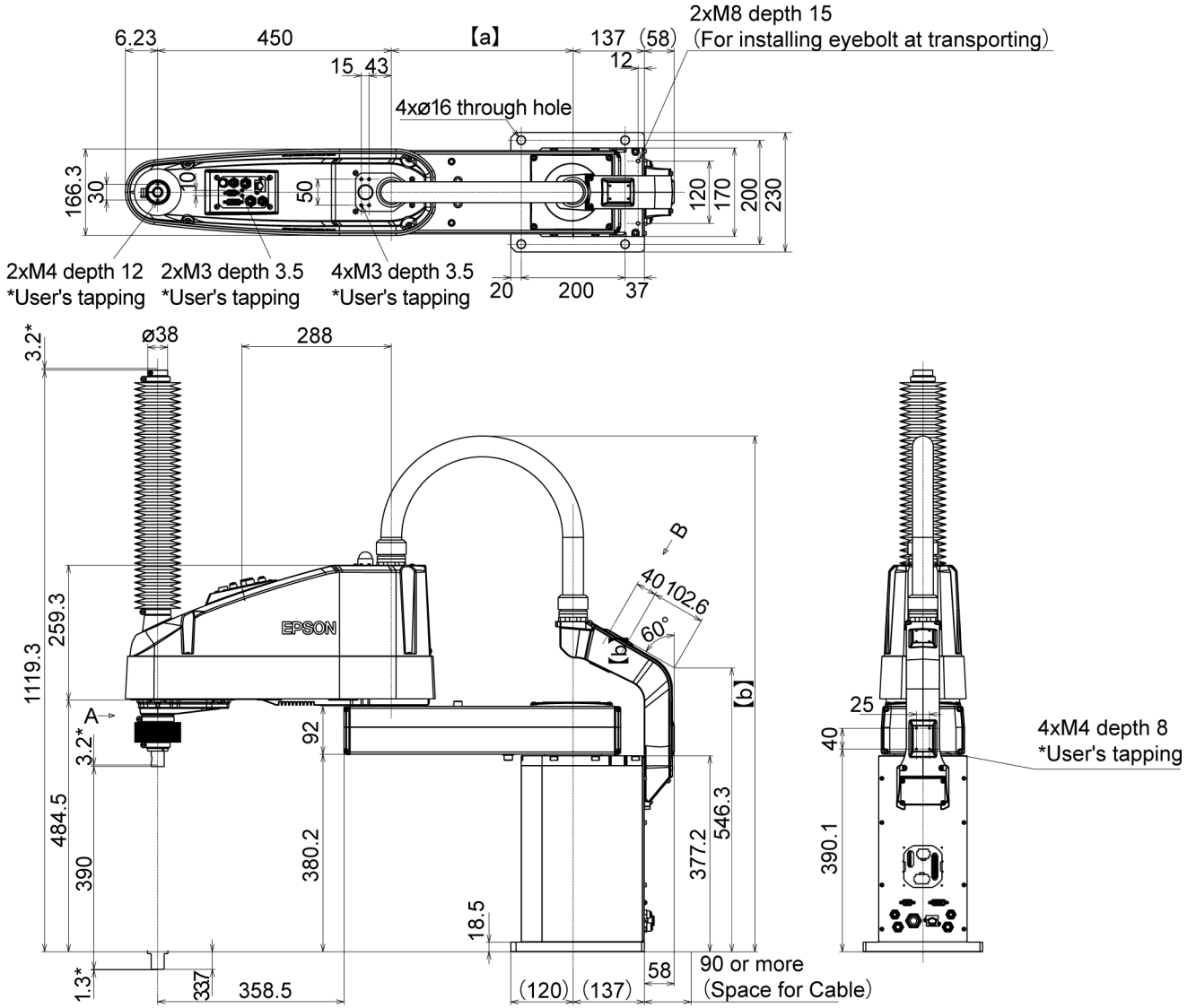

(\*:indicates mechanical stop position)

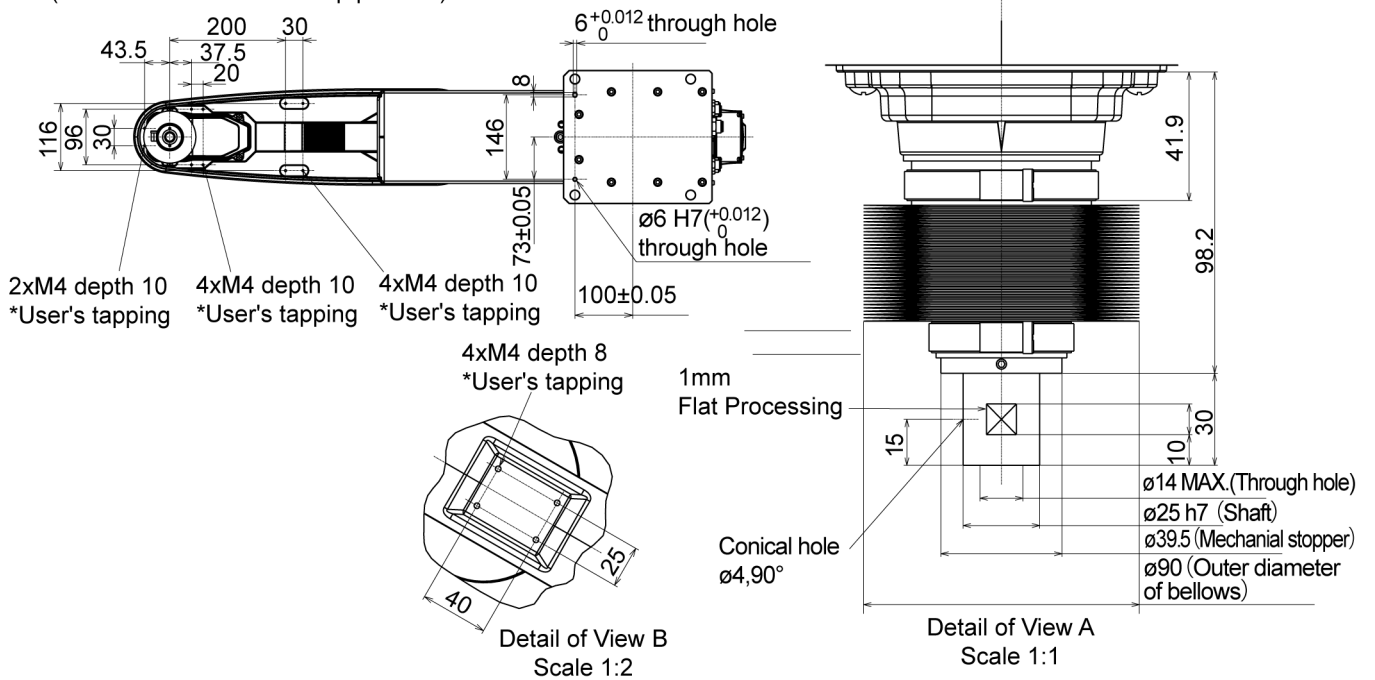

	LS20-C804S	LS20-CA04S
a	350	550
b	MAX. 1000	MAX. 1100

### 3.2.3 Specification table

For details on the specifications of each model, refer to the following:

[Appendix B: Specification Table](#)

### 3.2.4 How to Set the Model

The Manipulator model for your system has been set before shipment from the factory.

**⚠ CAUTION**

- If changing the setting of the Manipulator model, be responsible and absolutely certain that the wrong Manipulator model is not set. Incorrect setting of the Manipulator model may result in abnormal or no operation by the Manipulator and could even cause safety problems.

If a custom specifications number (MT\*\*\*) or (X\*\*\*) is written on the face plate (serial number label), the Manipulator has custom specifications.

Models with custom specifications may require a different setting procedure. Check the custom specifications number, and contact the supplier for more information.

The Manipulator model is set from software. For details, refer to the following manual.  
 "Epson RC+ User's Guide - Robot Configuration"

## 3.3 Environment and Installation

The robot system should be designed and installed by people who have received installation training provided by Epson and the suppliers. Also, the laws and regulations of the installation country must be followed.

### 3.3.1 Environment

A suitable environment is necessary for the robot system to function properly and safely. Be sure to install the robot system in an environment that meets the following conditions:

Item	Conditions
Ambient Temperature *	5 to 40°C
Ambient relative humidity	10 to 80 % (no condensation)
Fast transient burst noise	1 kV or less (Signal wire)
Electrostatic noise	4 kV or less
Altitude	1000 m or lower

Item	Conditions
Environment	<ul style="list-style-type: none"> <li>▪ Install indoors</li> <li>▪ Keep away from direct sunlight</li> <li>▪ Keep away from dust, oily smoke, salinity, metal powder and other contaminants</li> <li>▪ Keep away from flammable or corrosive solvents and gases</li> <li>▪ Keep away from water</li> <li>▪ Keep away from shock or vibration</li> <li>▪ Keep away from sources of electric noise</li> <li>▪ Keep away from explosive area</li> <li>▪ Keep away from a large quantity of radiation</li> </ul>

\* The ambient temperature conditions are for the Manipulator only. For the Controller the Manipulators are connected to, refer to the Controller Manual.

 **KEY POINTS**

- Manipulators are not suitable for operation in harsh environments such as painting areas, etc. When using Manipulators in inadequate environments that do not meet the above conditions, please contact the supplier of your region.
- When the product is used in a low temperature environment around the minimum temperature of the product specification, or when the product is suspended for a long time on holidays or at night, a collision detection error may occur due to the large resistance of the drive unit immediately after the start of operation. In such case, it is recommended to warm up for about 10 minutes.

**Special Environmental Conditions**

The surface of the Manipulator has general oil resistance. However, if your requirements specify that the Manipulator must withstand certain kinds of oil, please contact the supplier of your region.

Rapid change in temperature and humidity can cause condensation inside the Manipulator.

If your requirements specify that the Manipulator handles food, please contact the supplier of your region to check whether the Manipulator will damage the food or not.

The Manipulator cannot be used in corrosive environments where acid or alkaline is used. In a salty environment where the rust is likely to gather, the Manipulator is susceptible to rust.

 **WARNING**

- Always use a circuit breaker for the Controller's power supply. Failure to use a circuit breaker may result in an electrical shock hazard or malfunction due to an electrical leakage. Select the correct circuit breaker based on the Controller that you are using. For details, refer to the following manual.

## "Robot Controller Manual"

**⚠ CAUTION**

- When cleaning the Manipulator, do not rub it strongly with alcohol or benzene. Coated surfaces may lose their luster.

**3.3.2 Base Table**

Please make or obtain the base table to secure your Manipulator.

The shape and size of the base table differs depending on the use of the robot system. For your reference, we list some Manipulator table requirements here.

The base table must not only be able to bear the weight of the Manipulator but also be able to withstand the dynamic movement of the Manipulator when it operates at maximum acceleration/deceleration. Ensure that there is enough strength on the base table by attaching reinforcing materials such as crossbeams.

The torque and reaction force produced by the movement of the Manipulator are as follows:

	LS20-C
Max. reaction torque on the horizontal plate	1000 N·m
Max. horizontal reaction force	7500 N
Max. vertical reaction force	2000 N

**⚠ CAUTION**

If the vibration of the base table is large, reduce the acceleration/deceleration or increase the rigidity of the base table to reduce the vibration. Continued use in a state of large vibration may cause loosening of fastening parts or excessive load on mechanical parts, which may shorten the lifespan.

The threaded holes required for mounting the Manipulator base are M8. Use mounting bolts with specifications conforming to ISO898-1 property class 10.9 or 12.9. For dimensions, refer to the following.

**Mounting Dimensions**

The plate for the Manipulator mounting face should be 20 mm thick or more and made of steel to reduce vibration. The surface roughness of the steel plate should be 25 μm or less.

The table must be secured on the floor or wall to prevent it from moving.

The Manipulator installation surface should have a flatness of 0.5 mm or less and an inclination of 0.5° or less. If the flatness of the installation surface is improper, the base may be damaged, or the robot may not fully show its performance.

When using a leveler to adjust the height of the base table, use a screw with M16 diameter or more.

If you are passing cables through the holes on the base table, see the figures below.

(Unit : mm)

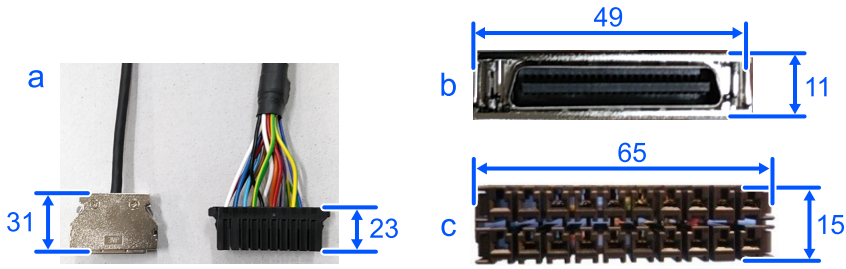

Symbol	Description
a	M/C Cables
b	Signal Cable Connector
c	Power Cable Connector

**KEY POINTS**

Do not remove the M/C cable from the Manipulator.

For environmental conditions regarding space when placing the Controller on the base table, refer to the Controller manual.

**WARNING**

To ensure safety, a safeguard must be installed for the robot system. For details on the safeguard, refer to the Epson RC+ User's Guide.

**3.3.3 Mounting Dimensions**

The maximum space (R) includes the radius of the end effector. If it exceeds 60 mm, define the radius as the distance to the outer edge of maximum space. If a camera or solenoid valve extends outside of the arm, set the maximum range including the space that they may reach.

Be sure to allow for the following extra spaces in addition to the space required for mounting the Manipulator, Controller, and peripheral equipment.

- Space for teaching
- Space for maintenance and inspection (Ensure a space to open the covers for maintenance.)
- Space for cables

**KEY POINTS**

- When installing the cable, be sure to maintain sufficient distance from obstacles.
- For the minimum bend radius of the MC cable, refer to the following:  
[LS20-C Specification Table](#)  
 For other cables, make sure to secure enough space so as not to excessively bend the cables.

Ensure distance to the safeguard from the maximum motion range is more than 100 mm.

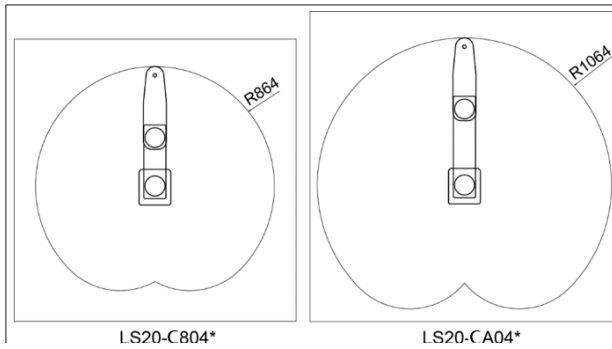

### 3.3.4 Unpacking and Transportation

Transportation and installation of the Manipulators shall be performed by personnel who has taken robot system training held by us and suppliers and should conform to all national and local codes.

#### **⚠ WARNING**

- Only authorized personnel should perform sling work and operate a crane and a forklift. When these operations are performed by unauthorized personnel, it is extremely hazardous and may result in serious bodily injury and/or severe equipment damage to the robot system.
- Stabilize the Manipulator with your hands when hoisting it. If you lose balance, the Manipulator may fall which could result in serious bodily injury and/or severe equipment damage.

#### **⚠ CAUTION**

- Using a cart or similar equipment, transport the Manipulator in the same manner as it was delivered.
- After removing the bolts securing the Manipulator to the delivery equipment, the Manipulator can fall. Be careful not to get hands or fingers caught.
- The arm is secured with a wire tie. Leave the wire tie secured until you finish the installation so as not to get hands or fingers caught.
- To carry the Manipulator, have two or more people to work on it and secure the Manipulator to the delivery equipment. Also, do not hold the shaded area in the figure. Doing so is extremely dangerous and can result in getting your hands and fingers caught.

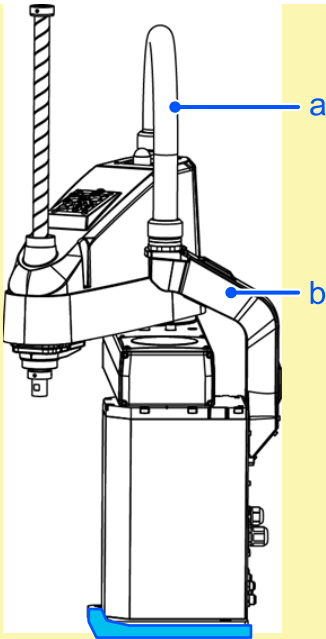

(Figure: LS20-C804S)

Symbol	Description
a	Resin Duct
b	Metal Duct

- LS20-C804\*: approx. 48 kg: 105.8 lbs. (pound)
- LS20-CA04\*: approx. 51 kg: 112.5 lbs. (pound)

- Do not hold the metal duct and the resin duct when transporting the Manipulator. Doing so may damage them.

### KEY POINTS

When transporting the Manipulator for a long distance, secure it to the delivery equipment directly so that the Manipulator never falls over. If necessary, pack the Manipulator in the same style as it was delivered.

Transport the Manipulator following the instructions below:

1. Attach the eye bolts to the upper side of the Base.
2. Turn the Arm #1 to face the front.
3. Pass the belts under Arm #2. Set the wire tie at the metal part (shaded area in the figure below) so that the belt cannot move.
4. Hoist the Manipulator slightly so that it does not fall over. Then, remove the bolts securing the Manipulator to the delivery equipment or a pallet.
5. Hoist the Manipulator attaching the hands at the positions indicated by arrows so that it can keep the balance. Then, move the Manipulator to the base table.

LS20-C804\*

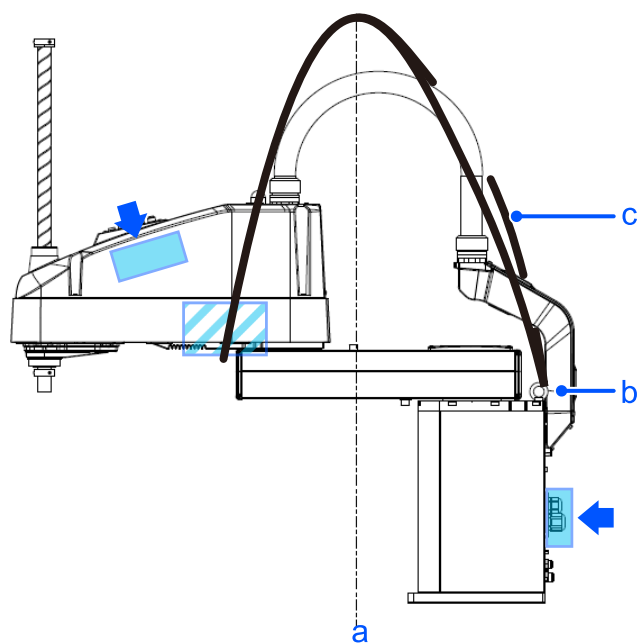

LS20-CA04\*

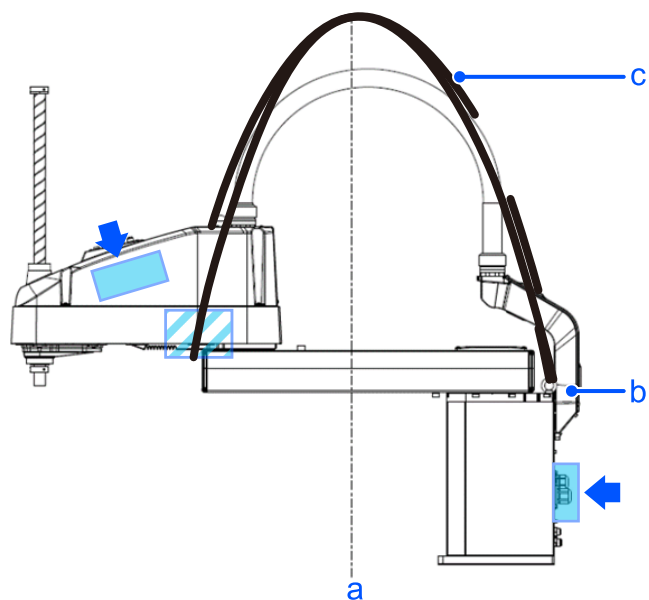

Symbol	Description
a	Center of gravity
b	Eye bolts
c	Belt

### 3.3.5 Installation Procedure

Installation shall be performed by personnel who has taken robot system training held by us and suppliers. Also, make sure to comply with the laws and regulations of each country.

**⚠ CAUTION**

- The robot system must be installed to avoid interference with buildings, structures, utilities, other machines and equipment that may create a trapping hazard or pinch points.
- Vibration (resonance) may occur during operation depending on rigidity of the base table. If vibration occurs, improve rigidity of the table or change the speed or acceleration and deceleration settings

#### 3.3.5.1 Standard environment specification

**⚠ CAUTION**

- Install and move the Manipulator with two or more people. The Manipulator weights are as follows. Be careful not to get hands or feet caught and/or have equipment damaged by the Manipulator falling.
  - LS20-C804\*: approx. 48 kg: 105.8 lbs. (pound)
  - LS20-CA04\*: approx. 51 kg: 112.5 lbs. (pound)

1. Secure the base to the base table with four bolts.

**✎ KEY POINTS**

Use bolts with specifications conforming to ISO898-1 Property Class 10.9 or 12.9.

Tightening torque: 73.5 N·m (750 kgf·cm)

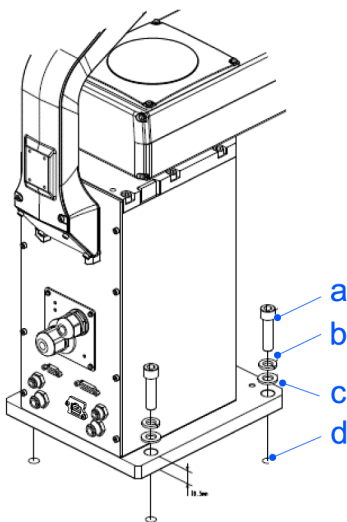

Symbol	Description
a	M12×40

Symbol	Description
b	Spring Washer
c	Plain Washer
d	Screw Hole

2. Using nippers, cut off the wire tie binding the arm. Remove the bolt.

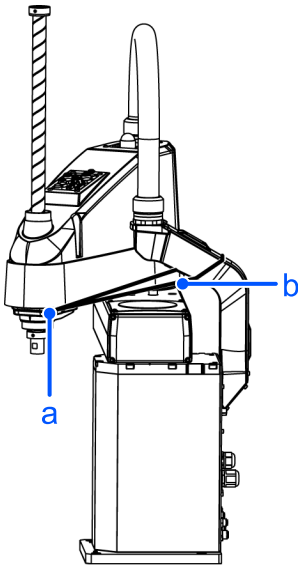

Symbol	Description
a	Bolt: M4
b	Wire tie

### 3.3.5.2 Cleanroom Environment Specification

1. Unpack the Manipulator outside of the cleanroom.
2. Secure the Manipulator to transporting equipment (or a pallet) with bolts so that the Manipulator does not fall down.
3. Wipe off any dust on the Manipulator using a lint-free cloth that was dipped in ethyl alcohol or distilled water.
4. Carry the Manipulator into the cleanroom.
5. Referring to the standard specification’s installation procedure, install the Manipulator.
6. Connect an exhaust tube to the exhaust port.

### 3.3.6 Connecting the Cables

**⚠ WARNING**

- To shut off power to the robot system, disconnect the power plug from the power source or use a disconnecter. Be sure to connect the AC power cable to either a power receptacle or a disconnecter. **DO NOT** connect it directly to a factory power source.
- Before performing any replacement procedure, turn OFF the Controller and related equipment, and then disconnect the power plug from the power source. Performing any replacement procedure with the power ON is extremely hazardous and may result in electric shock and/or malfunction of the robot system.

- Be sure to connect the cables properly. Do not allow unnecessary strain on the cables. (Do not put heavy objects on the cables. Do not bend or pull the cables forcibly.) The unnecessary strain on the cables may result in damage to the cables, disconnection, and/or contact failure.
- Grounding the manipulator is done by connecting with the controller. Ensure that the controller is grounded and the cables are correctly connected. If the ground wire is improperly connected to ground, it may result in the fire or electric shock.

### CAUTION

- When connecting the Manipulator to the Controller, make sure that the serial numbers on each equipment match. Improper connection between the Manipulator and Controller may not only cause improper function of the robot system but also serious safety problems. The connection method varies with the Controller used. For details on the specifications, refer to the Controller manual.
- Connecting cables to the Manipulator shall be performed by personnel who has taken robot system training held by us and suppliers. This should also be performed by qualified personnel with knowledge · skills in electricity. Cable connection performed by personnels without such knowledge · skill may result in injuries and malfunction.

If the manipulator is a cleanroom specification, pay attention to the following items.

If the manipulator is a cleanroom specification, the exhaust needs to be connected. For the exhaust system, refer to the following section.

## Appendix B: Specification Table

### 3.3.6.1 Method to Connect the Manipulator and M/C Cable

1. Set the M/C cable as shown below.

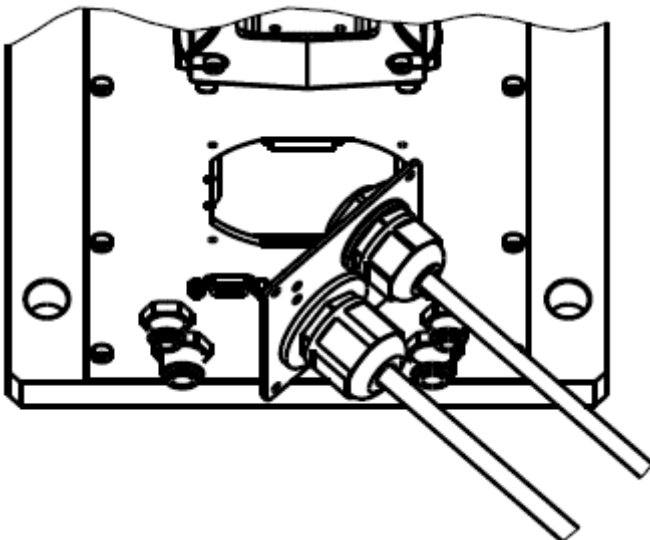

#### KEY POINTS

Be careful with the direction of the plate.

2. Connect the following connectors in the order shown below.

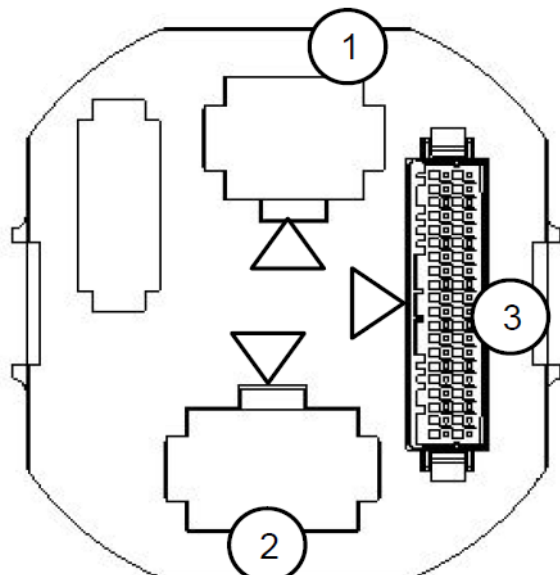

3. Install the plate.

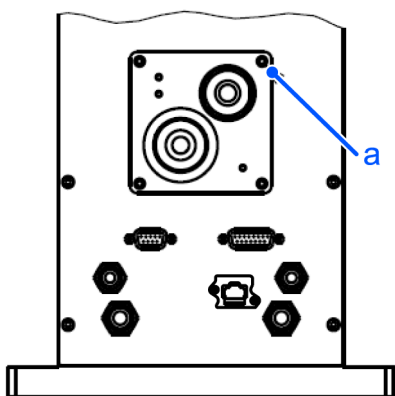

- Cross screw:  $4 \times M3 \times 6$
- Tightening torque:  $0.6 \pm 0.1 \text{ N}\cdot\text{m}$

#### KEY POINTS

Be careful not to tighten the screws with the cables caught on the plate.

### 3.3.6.2 Connecting M/C Cables and Controller

Connect the power connector and the signal connector of the M/C cable with each Controller.

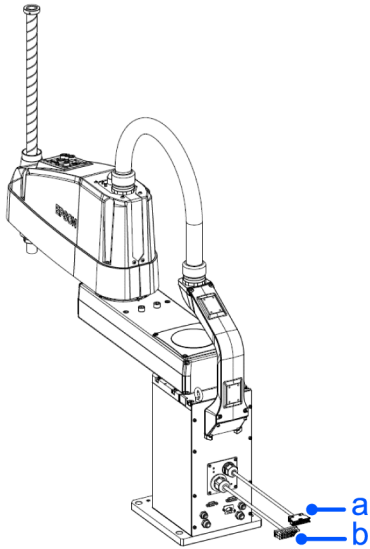

Symbol	Description
a	Signal Connector
b	Power Connector

There are two types of M/C cable: For fixing and movable. Movable cables have a line as shown in the figure below



### 3.3.7 Installed wire for customer use

**⚠ CAUTION**

- Only authorized or certified personnel should perform wiring. Wiring by unauthorized or uncertified staff may result in bodily injury and/or malfunction of the robot system.

User electrical wires and pneumatic tubes are contained in the cable unit.

#### Electrical Wires

Rated Voltage	Allowable Current	Wires	Nominal Sectional Area	Note
AC/DC30V	1A	15	0.211 mm <sup>2</sup>	Twist pair/no shielding

Rated Voltage	Allowable Current	Wires	Nominal Sectional Area	Note
		9		

**⚠ WARNING**

Do not apply the current more than 1A to the manipulator.

		Manufacturer	Standard
15 pin	Compatible connector	JAE	DA-15PF-N (Solder type)
	Clamp Hood		DA-C8-J10-F2-1R (Connectors setscrew: #4-40 NC)
9 pin	Compatible connector		DE-9PF-N (Solder type)
	Clamp Hood		DE-C8-J9-F2-1R (Connectors setscrew: #4-40 NC)

Each connector is wired with pins that have the same number between the connectors.

**Pneumatic Tubes**

Max. Usable Pneumatic Pressure	The number of bolts	Outer Diameter×Inner Diameter
0.59Mpa (6 kgf/cm <sup>2</sup> : 86psi)	2	ø6 mm× ø4 mm
	2	ø8 mm× ø5 mm

Fittings for ø6 mm and ø8 mm (outer diameter) pneumatic tubes are supplied on both ends of the pneumatic tubes.

**✎ KEY POINTS**

All fittings for ø6 mm, ø8 mm pneumatic tubes of LS20-C series are white. Be sure to check the numbers near the fittings and connect them properly.

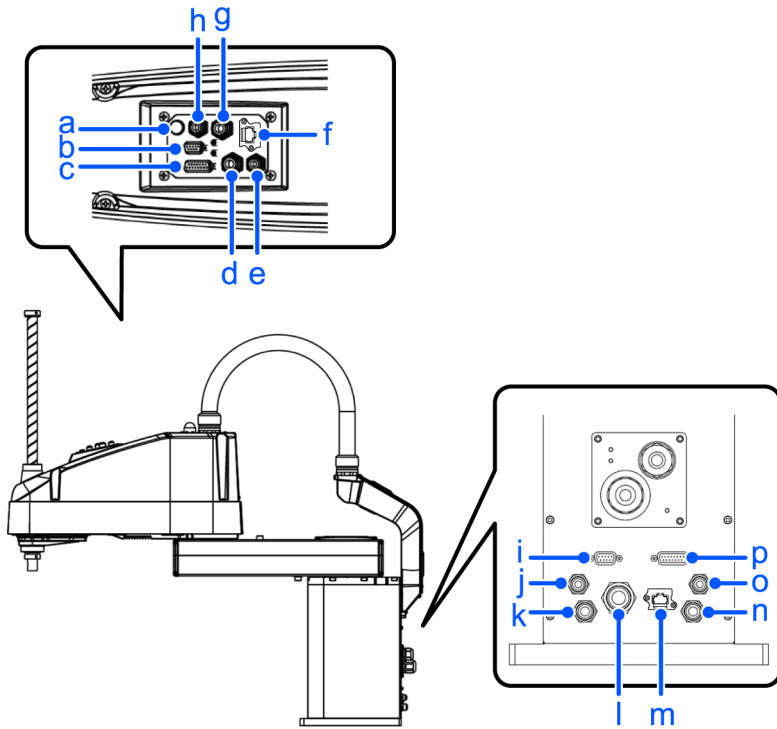

Symbol	Description
a	Brake release switch
b	User connector (9-pin D-sub connector)
c	User connector (15-pin D-sub connector)
d	Fitting (No.2) for ø8 mm pneumatic tube
e	Fitting (No.1) for ø6 mm pneumatic tube
f	Ethernet connector
g	Fitting (No.3) for ø8 mm pneumatic tube
h	Fitting (No.4) for ø6 mm pneumatic tube
i	User connector (9-pin D-sub connector)
j	Fitting (No.1) for ø6 mm pneumatic tube
k	Fitting (No.2) for ø8 mm pneumatic tube
l	Exhaust port (Cleanroom specification only)
m	Ethernet connector
n	Fittings for ø8 mm pneumatic tube (No. 3)
o	Fittings for ø6 mm pneumatic tube (No. 4)
p	User connector (15-pin D-sub connector)

### 3.3.8 Relocation and Storage

#### 3.3.8.1 Precautions for Relocation and Storage

Observe the following when relocating, storing, and transporting the Manipulators.

Transportation and installation of the Manipulator and robotic equipment shall be performed by personnel who has taken robot system training held by us and suppliers and should conform to all national and local codes.

**⚠ WARNING**

- Only authorized personnel should perform sling work and operate a crane and a forklift. When these operations are performed by unauthorized personnel, it is extremely hazardous and may result in serious bodily injury and/or severe equipment damage to the robot system.
- Stabilize the Manipulator with your hands when hoisting it. If you lose balance, the Manipulator may fall which could result in serious bodily injury and/or severe equipment damage.

**⚠ CAUTION**

- Before relocating the Manipulator, fold the arm and secure it tightly with a wire tie to prevent hands or fingers from being caught in the Manipulator.
- When removing the anchor bolts, support the Manipulator to prevent falling. Removing the anchor bolts without support may result in the Manipulator to fall, and then get hands, fingers, or feet caught.
- To carry the Manipulator, have two or more people to work on it and secure the Manipulator to the delivery equipment. Also, do not hold the shaded area in the figure. Doing so is extremely dangerous and can result in getting your hands and fingers caught.

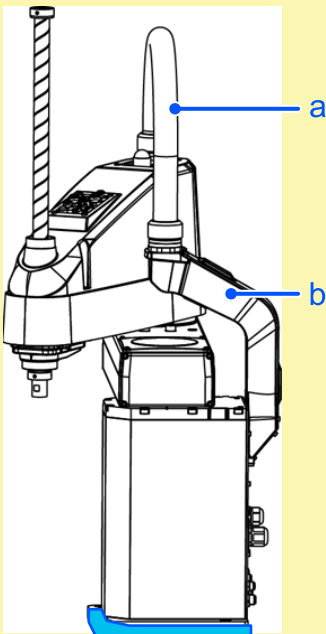

Symbol	Description
a	Resin Duct
b	Metal Duct

- LS20-C804\*: approx. 48 kg: 105.8 lbs. (pound)
- LS20-CA04\*: approx. 51 kg: 112.5 lbs. (pound)

(Figure: LS20-C804S)

- Do not hold the metal duct and the resin duct when transporting the Manipulator. Doing so may damage them.

## KEY POINTS

When transporting the Manipulator for a long distance, secure it to the delivery equipment directly so that the Manipulator never falls over. If necessary, pack the Manipulator in the same style as it was delivered.

When the Manipulator is used for a robot system again after long-term storage, perform a test run to verify that it works properly, and then operate it thoroughly.

Transport and store the Manipulator in the range of Temperature:  $-20$  to  $+60$  °C, Humidity: 10 to 90% (no condensation).

When condensation occurs on the Manipulator during transport or storage, turn ON the power only after the condensation dries.

Do not shock or shake the Manipulator during transport.

### 3.3.8.2 Relocation

#### CAUTION

Install or relocate the Manipulator with two or more people. The Manipulator weights are as follows. Be careful not to get hands or feet caught and/or have equipment damaged by the Manipulator falling.

- LS20-C804\*: approx. 48 kg: 105.8 lbs. (pound)
- LS20-CA04\*: approx. 51 kg: 112.5 lbs. (pound)

1. Turn OFF the power on all devices and unplug the cables. Remove the mechanical stops if using them to limit the motion range of Joints #1 and #2. For details on the motion range, refer to the following.

#### **Motion Range Setting by Mechanical Stops**

2. Cover the arm with a sheet so that the arm will not be damaged. Insert the bolt to the screw hole on the arm and tie the bolt with the metal duct using a string. When fixing the arm using the shaft, fix it with adequate strength so as not to deform the spline. For details on the strength of the ball screw spline, refer to

#### **Strength of the Ball Screw Spline**

#### **Example of Securing the Arm**

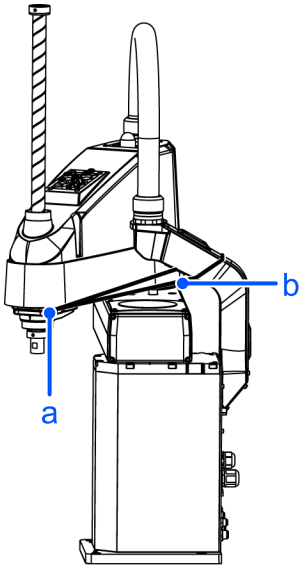

Symbol	Description
a	Bolt: M4
b	Wire tie

3. Hold the bottom of Arm #1 by hand to unscrew the anchor bolts. Then, remove the Manipulator from the base table.

**LS20-C804\***

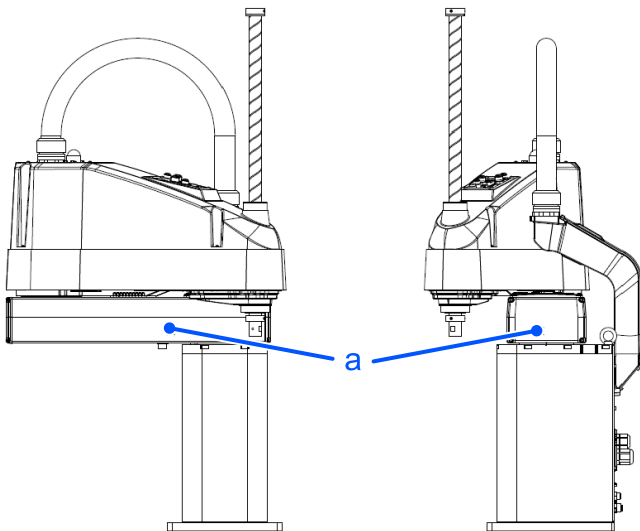

**LS20-CA04\***

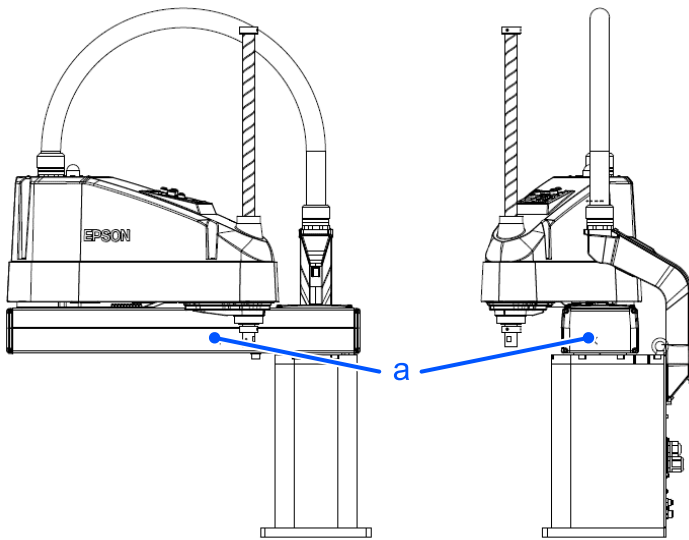

Symbol	Description
a	Center of gravity

### 3.4 Setting of End Effectors

#### 3.4.1 Attaching and End Effector

Users are responsible for making their own end effector(s). Be careful of the following points when attaching an end effector. For details on attaching a hand, refer to the following manual:

"Hand Function Manual"

**⚠ CAUTION**

- If you use an end effector equipped with a gripper or chuck, connect wires and/or pneumatic tubes properly so that the gripper does not release the workpiece when the power to the robot system is turned OFF. Improper connection of the wires and/or pneumatic tubes may damage the robot system and/or work piece as the work piece is released when the Emergency Stop switch is pressed.
- I/O outputs are configured at the factory so that they are automatically shut off (0) by power disconnection, the Emergency Stop switch, or the safety features of the robot system. However, the I/O set in the hand function does not turn off (0) when the Reset command is executed or in emergency stop.

#### Shaft

- Attach an end effector to the lower end of the shaft. For the shaft dimensions, and the overall dimensions of the Manipulator, refer to the following.

#### Specification

- Do not move the upper limit mechanical stop on the lower side of the shaft. Otherwise, when “Jump motion” is performed, the upper limit mechanical stop may hit the Manipulator, and the robot system may not function properly.
- Use a split muff coupling with an M4 bolt or larger to attach the end effector to the shaft.

#### Brake release switch

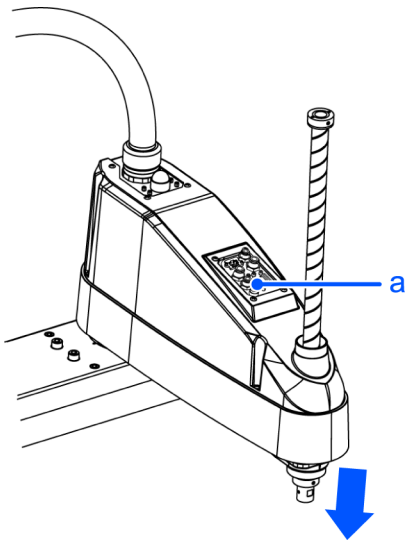

Shaft may be lowered by the weight of the end effector.

Symbol	Description
a	Brake release switch

- Joint #3 and #4 cannot be moved up/down by hand because the electromagnetic brake is applied to the joint while power to the robot system is turned OFF. This prevents the shaft from hitting peripheral equipment in the case that the shaft is lowered by the weight of the end effector when the power is disconnected during operation, or when the motor is turned OFF even though the power is turned ON.

To move Joint #3 up/down or rotate Joint #4 while attaching an end effector, turn ON the Controller and move the joint up/down or rotate the joint while pressing the brake release switch. This button switch is a momentary-type; the brake is released only while the button switch is being pressed

- Be careful of the shaft falling and rotating due to hand weight while the brake release switch is being pressed.

**Layouts**

- When you operate the manipulator with an end effector, the end effector may interfere with the Manipulator because of the outer diameter of the end effector, the size of the workpiece, or the position of the arms. When designing your system layout, pay attention to the interference area of the end effector.

**3.4.2 Attaching Cameras and Valves**

Arm #2 has threaded holes as shown in the figure below. Use M3 threaded holes on the top when attaching Ethernet cable to the arm. Use M4 threaded holes on the bottom when attaching a camera or air valve to the arm.

(Unit : mm)

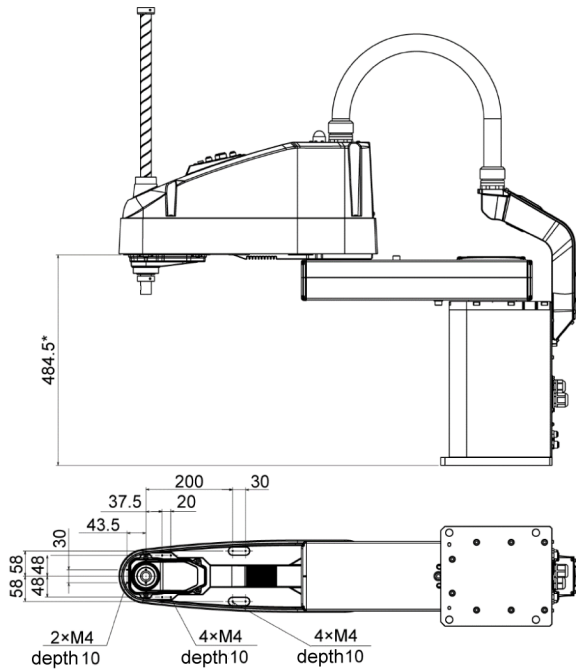

\*: From base installation surface

### 3.4.3 Weight and Inertia Settings

To ensure optimum Manipulator performance, it is important to make sure that the load (weight of the end effector and workpiece) and moment of inertia of the load are within the maximum rating for the Manipulator, and that Joint #4 does not become eccentric. If the load or moment of inertia exceeds the rating or if the load becomes eccentric, follow the steps below to set parameters.

- **Weight Setting**
- **Inertia Setting**

Setting parameters makes the PTP motion of the Manipulator optimal, reduces vibration to shorten the operating time, and improves the capacity for larger loads. In addition, it reduces persistent vibration produced when the moment of inertia of the end effector and work piece is larger than the default setting.

It can also be set from “Weight, Inertia, and Eccentricity/Offset Measurement”. For details, refer to the following manual.

“Epson RC+ User’s Guide - Weight, Inertia, and Eccentricity/Offset Measurement Utility”

#### 3.4.3.1 Weight Setting

**⚠ CAUTION**

The total weight of the end effector and the workpiece must not exceed 20 kg. The LS20-C series are not designed to work with loads exceeding 20 kg. Always set the value according to the load. Setting a value that is smaller than the actual load may cause errors, shock and insufficient function of the Manipulator. Also, the life cycle of parts will shorten and belt tooth jumping will occur which will lead to position shift.

The acceptable weight capacity (end effector and workpiece) in LS20-C series

- Rated weight: 10 kg
- Maximum: 20 kg

If the load weight exceeds the rated weight, change the setting for the hand weight parameter in the Weight command. After the setting is changed, the maximum acceleration/deceleration speed of the robot system at PTP motion corresponding to the “Weight Parameter” is set automatically.

### 3.4.3.2 Load on the Shaft

The load (weight of the end effector and work piece) on the shaft can be set by Weight parameter.

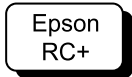

Enter a value into the [Weight:] text box on the [Weight] panel ([Tools]-[Robot Manager]). (You may also execute the Weight command from the [Command Window].)

### 3.4.3.3 Load on the Arm

When you attach a camera, valve or other devices to the arm, calculate the weight as the equivalent of the shaft. Then, add this to the weight of the load attached to the shaft, and enter the total weight to the Weight parameter.

#### Equivalent Weight Formula

When attached to the root of Arm #2:  $W_M = M(L_M + L_1)^2 / (L_1 + L_2)^2$

- $W_M$ : equivalent weight
- M: Weight of camera etc.
- $L_1$ : length of Arm #1
- $L_2$ : length of Arm #2
- $L_M$ : distance from rotation center of Joint #2 to center of gravity of the camera etc.

[Example]

Calculates [Weight] parameter when a “1 kg” camera is attached to the end of the LS20-C arm (550 mm away from the rotation center of Joint #2) with a load weight of “1 kg”.

$$W=1$$

$$M=1$$

$$L_1=350$$

$$L_2=450$$

$$L_M=550$$

$$W_M = 1 \times (550 + 350)^2 / (350 + 450)^2 = 1.27$$

(Round up to two decimal)

$$W + W_M = 1 + 1.27 = 2.27$$

Enter “2.27” for the Weight Parameter.

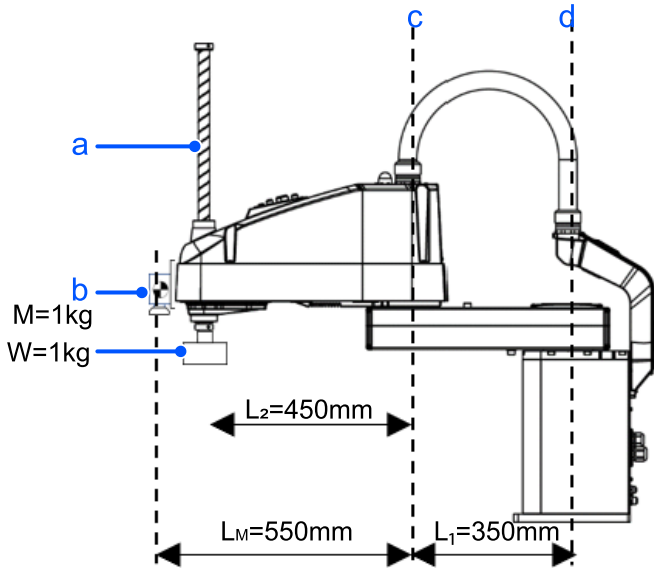

Symbol	Description
a	Shaft
b	Weight of the entire camera
c	Joint #2
d	Joint #1

### 3.4.3.4 Automatic speed setting by Weight

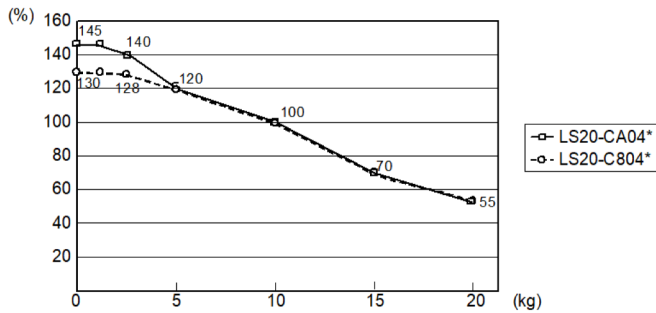

\* The percentage in the graph is based on the acceleration/ deceleration at rated weight (10 kg) as 100%.

End effector weight (kg)	Automatic speed setting by Weight (%)	
	LS20-C804 *	LS20-CA04*
0	130	145
1	130	145
2	128	140
5	120	120
10	100	100
15	70	70
20	55	55

### 3.4.3.5 Automatic acceleration/deceleration setting by Weight

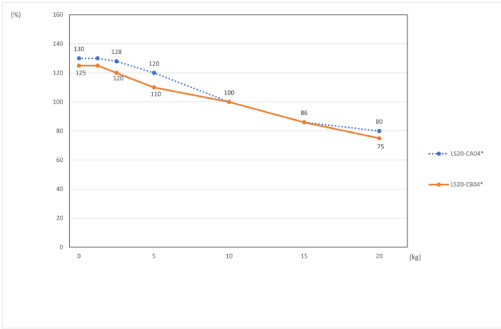

\* The percentage in the graph is based on the acceleration/ deceleration at rated weight (10 kg) as 100%.

End effector weight (kg)	Automatic acceleration/deceleration setting by Weight	
	LS20-C804 *	LS20-CA04*
0	130	125
1	130	125
2	128	120
5	120	110
10	100	100
15	86	86
20	80	75

### 3.4.3.6 Inertia Setting

#### 3.4.3.6.1 Moment of Inertia and the Inertia Setting

The moment of inertia is defined as “the ratio of the torque applied to a rigid body and its resistance to motion”. This value is typically referred to as “the moment of inertia”, “inertia”, or “GD2”. When the Manipulator operates with additional objects (such as an end effector) attached to the shaft, the moment of inertia of load must be considered.

**⚠ CAUTION**

The moment of inertia of the load (weight of the end effector and workpiece) must be  $1.0 \text{ kg}\cdot\text{m}^2$  or less. The LS20-C series are not designed to work with a moment of inertia exceeding  $1.0 \text{ kg}\cdot\text{m}^2$ . Always set the value according to the moment of inertia. Setting a value that is smaller than the actual moment of inertia may cause errors, shock and insufficient function of the Manipulator. Also, the life cycle of parts may be shortened and positional gap due to belt tooth bumping may occur.

The acceptable moment of inertia of load for a LS20-C series

- Rated weight:  $0.05 \text{ kg}\cdot\text{m}^2$
- Maximum:  $1.00 \text{ kg}\cdot\text{m}^2$

If the moment of inertia of the load exceeds the rated weight, change the setting of the moment of inertia parameter of the Inertia command. After the setting is changed, the maximum acceleration/deceleration speed of Joint #4 at PTP motion corresponding to the “moment of inertia” value is set automatically.

**3.4.3.6.2 Moment of inertia of load on the shaft**

The moment of inertia of load (weight of the end effector and workpiece) on the shaft can be set by the “moment of inertia” parameter of the Inertia command.

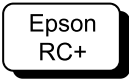

Enter a value into the [Moment of inertia] text box on the [Weight] panel ([Tools]-[Robot Manager]). (You may also execute the Inertia command from the [Command Window].)

**3.4.3.6.3 Automatic acceleration/deceleration setting of Joint #4 by Inertia (moment of inertia)**

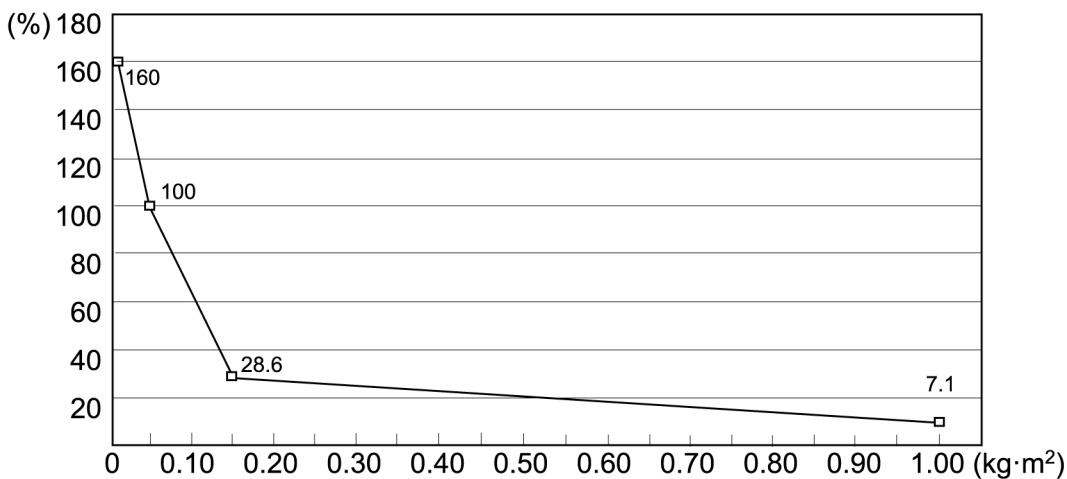

Moment of inertia setting parameter (kg·m <sup>2</sup> )	Automatic acceleration/deceleration (%) setting of Joint #4 by Inertia (moment of inertia)
0.01	160
0.05	100
0.15	28.6
1.00	7.1

**3.4.3.6.4 Eccentric Quantity and the Inertia Setting**

**⚠ CAUTION**  
 The eccentric quantity of the end effector and the workpiece must not exceed 200 mm. The LS20-C series are not designed to work with eccentric quantity exceeding 200 mm. Always set the Weight parameters according to the load. Setting a value that is smaller than the actual load may cause errors, excessive shock and insufficient

function of the Manipulator. Also, the life cycle of parts may be shortened and positional gap due to belt tooth bumping may occur.

The acceptable eccentric quantity of load in LS20-C series is 0 mm at the default rating and 200 mm at the maximum. If the moment of inertia of the load exceeds the default rating, change the setting of eccentric quantity parameter of Inertia command. After the setting is changed, the maximum acceleration/deceleration speed of the Manipulator at PTP motion corresponding to the “eccentric quantity” is set automatically.

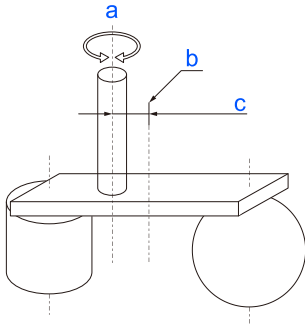

Symbol	Description
a	Rotation center
b	Position of load’s center of gravity
c	Eccentric quantity

### 3.4.3.6.5 Eccentric quantity of load on the shaft

The eccentric quantity of load (weight of the end effector and workpiece) on the shaft can be set by “eccentric quantity” parameter of Inertia command.

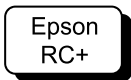

Enter a value into the [Eccentricity:] text box on the [Inertia] panel ([Tools]-[Robot Manager]). (You may also execute the Inertia command from the [Command Window].)

### 3.4.3.6.6 Automatic acceleration/deceleration setting by Inertia (eccentric quantity)

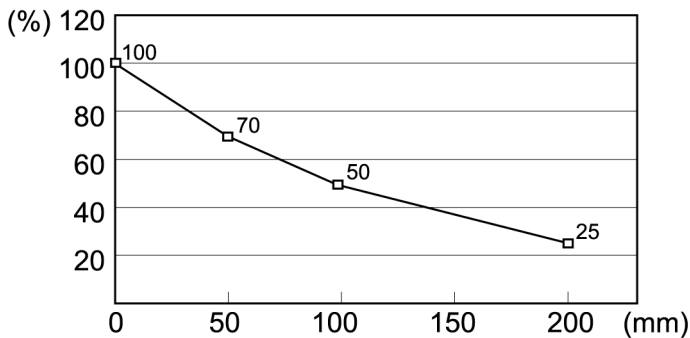

Eccentric quantity parameter (mm)	Automatic acceleration/deceleration setting by Inertia (eccentric quantity) (%)
0	100

Eccentric quantity parameter (mm)	Automatic acceleration/deceleration setting by Inertia (eccentric quantity) (%)
50	70
100	50
200	25

### 3.4.3.6.7 Calculating the Moment of Inertia

Refer to the following examples of formulas to calculate the moment of inertia of load (end effector with workpiece). The moment of inertia of the entire load is calculated by the sum of each part (a), (b), and (c).

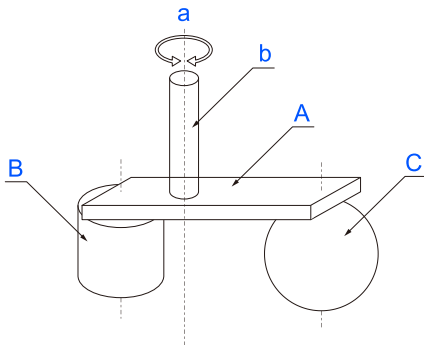

$$\text{Whole moment of inertia} = \text{Moment of inertia of end effector (A)} + \text{Moment of inertia of work piece (B)} + \text{Moment of inertia of work piece (C)}$$

Symbol	Description
a	End effector
b	Workpiece
c	Workpiece
d	Shaft
e	Rotation center

The methods for calculating the moment of inertia for (a), (b), and (c) are shown below. Calculate the total moment of inertia using the basic formulas.

#### (a) Moment of inertia of a rectangular parallelepiped

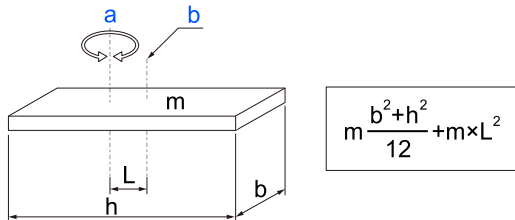

Symbol	Description
a	Rotation center
b	Rectangular parallelepiped's center of gravity

**(b) Moment of inertia of a cylinder**

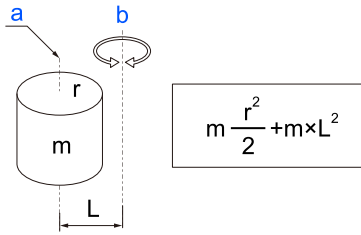

Symbol	Description
a	Cylinder's center of gravity
b	Rotation center

**(c) Moment of inertia of a sphere**

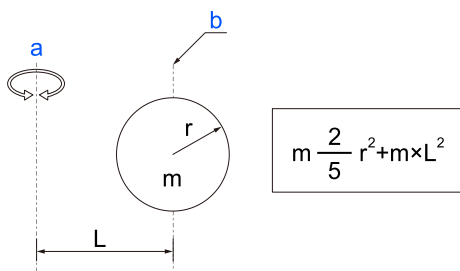

Symbol	Description
a	Rotation center
b	Sphere's center of gravity

**3.4.3.6.8 Moment of Inertia and the Inertia Setting**

The moment of inertia is defined as “the ratio of the torque applied to a rigid body and its resistance to motion”. This value is typically referred to as “the moment of inertia”, “inertia”, or “GD2”. When the Manipulator operates with additional objects (such as an end effector) attached to the shaft, the moment of inertia of load must be considered.

**⚠ CAUTION**

The moment of inertia of the load (weight of the end effector and workpiece) must be 2.45 kg·m<sup>2</sup> or less. The LS50-C series are not designed to work with a moment of inertia exceeding 2.45 kg·m<sup>2</sup>. Always set the value according to the moment of inertia. Setting a value that is smaller than the actual moment of inertia may cause errors, shock and insufficient function of the Manipulator. Also, the life cycle of parts may be shortened and positional gap due to belt tooth bumping may occur.

The acceptable moment of inertia of load for a LS50-C series

- Rated weight: 1.00 kg·m<sup>2</sup>
- Maximum: 2.45 kg·m<sup>2</sup>

If the moment of inertia of the load exceeds the rated weight, change the setting of the moment of inertia parameter of the Inertia command. After the setting is changed, the maximum acceleration/deceleration speed of Joint #4 at PTP motion corresponding to the “moment of inertia” value is set automatically.

### 3.4.3.6.9 Moment of inertia of load on the shaft

The moment of inertia of load (weight of the end effector and workpiece) on the shaft can be set by the “moment of inertia” parameter of the Inertia command.

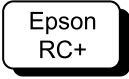

Enter a value into the [Moment of inertia] text box on the [Weight] panel ([Tools]-[Robot Manager]). (You may also execute the Inertia command from the [Command Window].)

### 3.4.3.6.10 Automatic acceleration/deceleration setting of Joint #4 by Inertia (moment of inertia)

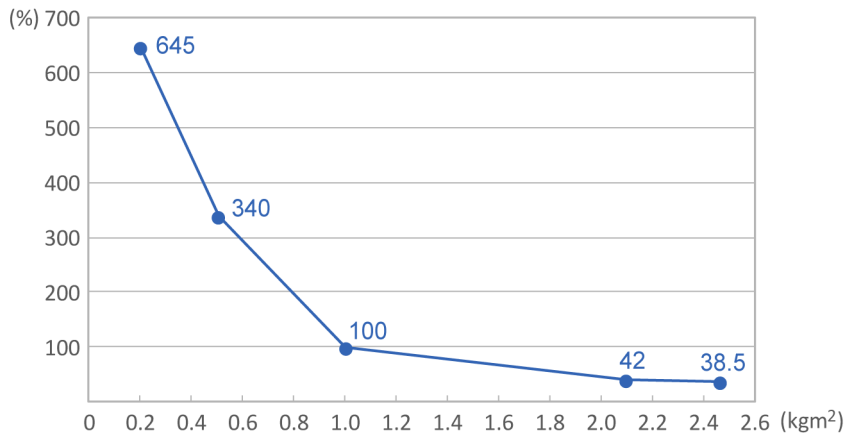

Moment of inertia setting parameter (kg·m <sup>2</sup> )	Automatic acceleration/deceleration (%) setting of Joint #4 by Inertia (moment of inertia)
0.2	645
0.5	340
1	100
2.1	42
2.45	38.5

### 3.4.3.6.11 Eccentric Quantity and the Inertia Setting

#### CAUTION

The eccentric quantity of the end effector and the workpiece must not exceed 200 mm. The LS50-C series are not designed to work with eccentric quantity exceeding 200 mm. Always set the Weight parameters according to the load. Setting a value that is smaller than the actual load may cause errors, excessive shock and insufficient function of the Manipulator. Also, the life cycle of parts may be shortened and positional gap due to belt tooth bumping may occur.

The acceptable eccentric quantity of load in LS50-C series is 0 mm at the default rating and 200 mm at the maximum. If the moment of inertia of the load exceeds the default rating, change the setting of eccentric quantity parameter of Inertia command.

After the setting is changed, the maximum acceleration/deceleration speed of the Manipulator at PTP motion corresponding to the “eccentric quantity” is set automatically.

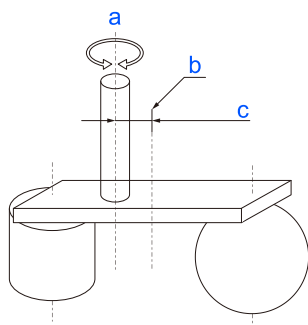

Symbol	Description
a	Rotation center
b	Position of load's center of gravity
c	Eccentric quantity

### 3.4.3.6.12 Eccentric quantity of load on the shaft

The eccentric quantity of load (weight of the end effector and workpiece) on the shaft can be set by “eccentric quantity” parameter of Inertia command.

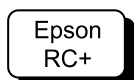

Enter a value into the [Eccentricity:] text box on the [Inertia] panel ([Tools]-[Robot Manager]). (You may also execute the Inertia command from the [Command Window].)

### 3.4.3.6.13 Automatic acceleration/deceleration setting by Inertia (eccentric quantity)

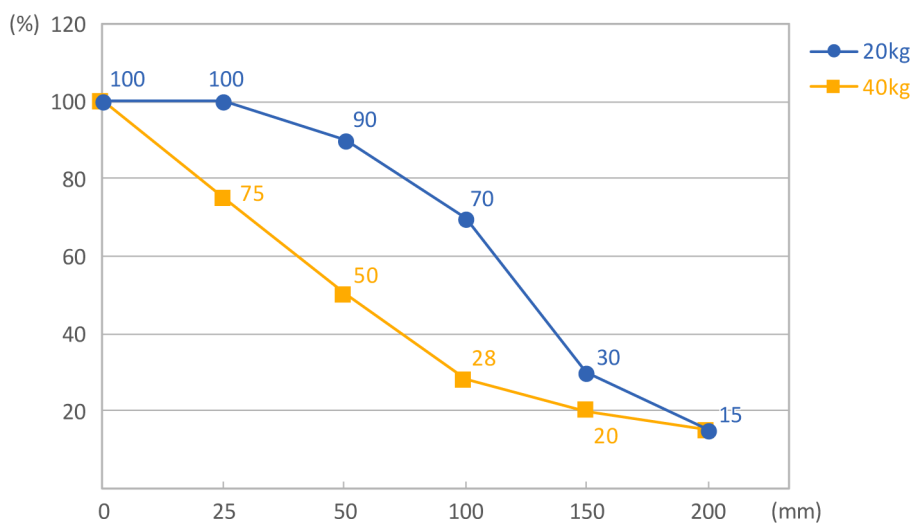

Eccentric quantity parameter (mm)	Automatic acceleration/deceleration setting by Inertia (eccentric quantity) (%)	
	20 kg	40 kg
0	100	100
25	100	70
50	90	50
100	70	28
150	30	20
200	15	15

**3.4.3.6.14 Calculating the Moment of Inertia**

Refer to the following examples of formulas to calculate the moment of inertia of load (end effector with workpiece).

The moment of inertia of the entire load is calculated by the sum of each part (A), (B), and (C).

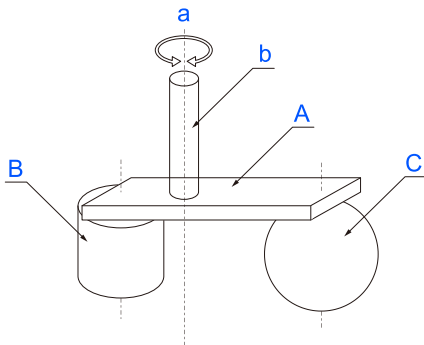

$$\text{Whole moment of inertia} = \text{Moment of inertia of end effector (A)} + \text{Moment of inertia of work piece (B)} + \text{Moment of inertia of work piece (C)}$$

Symbol	Description
a	Rotation center
b	Shaft
A	End effector
B	Workpiece
C	Workpiece

The methods for calculating the moment of inertia for (a), (b), and (c) are shown below. Calculate the total moment of inertia using the basic formulas.

**(A) Moment of inertia of a rectangular parallelepiped**

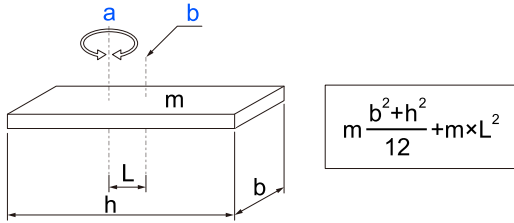

Symbol	Description
a	Rotation center
c	Rectangular parallelepiped's center of gravity

**(b) Moment of inertia of a cylinder**

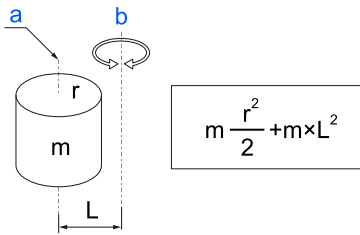

Symbol	Description
a	Cylinder's center of gravity
b	Rotation center

**(C) Moment of inertia of a sphere**

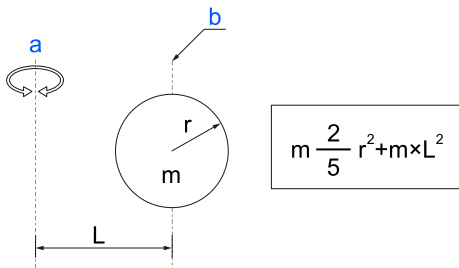

Symbol	Description
a	Rotation center
b	Sphere's center of gravity

**3.4.3.7 Moment of Inertia and the Inertia Setting**

The moment of inertia is defined as “the ratio of the torque applied to a rigid body and its resistance to motion”. This value is typically referred to as “the moment of inertia”, “inertia”, or “GD2”. When the Manipulator operates with additional objects (such as an end effector) attached to the shaft, the moment of inertia of load must be considered.

**⚠ CAUTION**

- The moment of inertia of the load (weight of the end effector and workpiece) must be 1.0 kg m<sup>2</sup> or less. The LS20-C series are not designed to work with a moment of inertia exceeding 1.0 kg m<sup>2</sup>. Always set the value according to the moment of inertia. Setting a value that is smaller than the actual moment of inertia may

cause errors, shock and insufficient function of the Manipulator. Also, the life cycle of parts may be shortened and positional gap due to belt tooth bumping may occur.

The acceptable moment of inertia of load for a LS20-C series

- Rated weight: 0.05 kg m<sup>2</sup>
- Maximum: 1.00 kg m<sup>2</sup>

If the moment of inertia of the load exceeds the rated weight, change the setting of the moment of inertia parameter of the Inertia command. After the setting is changed, the maximum acceleration/deceleration speed of Joint #4 at PTP motion corresponding to the “moment of inertia” value is set automatically.

### 3.4.3.8 Moment of inertia of load on the shaft

The moment of inertia of load (weight of the end effector and workpiece) on the shaft can be set by the “moment of inertia” parameter of the Inertia command.

Epson  
RC+

Enter a value into the [Moment of inertia] text box on the [Weight] panel ([Tools]-[Robot Manager]). (You may also execute the Inertia command from the [Command Window].)

### 3.4.3.9 Eccentric quantity of load on the shaft

The eccentric quantity of load (weight of the end effector and workpiece) on the shaft can be set by “eccentric quantity” parameter of Inertia command.

Epson  
RC+

Enter a value into the [Eccentricity:] text box on the [Inertia] panel ([Tools]-[Robot Manager]). (You may also execute the Inertia command from the [Command Window].)

## 3.4.4 Precautions for Auto Acceleration/Deceleration of Joint #3

When you move the Manipulator in horizontal PTP motion with Joint #3 (Z) at a high position, the motion time will be faster.

When Joint #3 gets below a certain point, then auto acceleration/deceleration is used to reduce acceleration/deceleration. (Refer to the figures below) The higher the position of the shaft is, the faster the motion acceleration/deceleration is. However, it takes more time to move Joint #3 up and down. Adjust the position of Joint #3 for the Manipulator motion after considering the relation between the current position and the destination position.

The upper limit of Joint #3 during horizontal motion using Jump command can be set by the LimZ command.

### 3.4.4.1 Automatic acceleration/deceleration vs. Joint #3 position

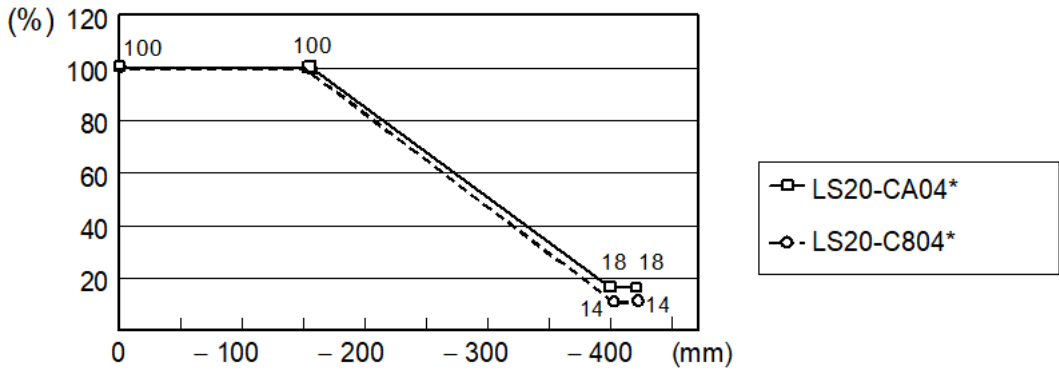

**KEY POINTS**

When moving the Manipulator horizontally while the shaft is being lowered, it may cause over-shoot at the time of final positioning.

Shaft height (mm)	Acceleration/Deceleration	
	LS20-C804 *	LS20-CA04*
0	100	100
-150	100	100
-400	14	18
-420	14	18

## 3.5 Motion Range

**CAUTION**

When setting up the motion range for safety, both the pulse range and mechanical stops must always be set at the same time.

The motion range is preset at the factory as explained in the following section.

### Standard Motion Range

This is the maximum motion range of the Manipulator.

There are three methods for setting the motion range described as follows:

1. Setting by pulse range (for all joints)
2. Setting by mechanical stops (for Joints #1 to #2)
3. Setting the Cartesian (rectangular) range in the X, Y coordinate system of the Manipulator (for Joints #1 and #2)

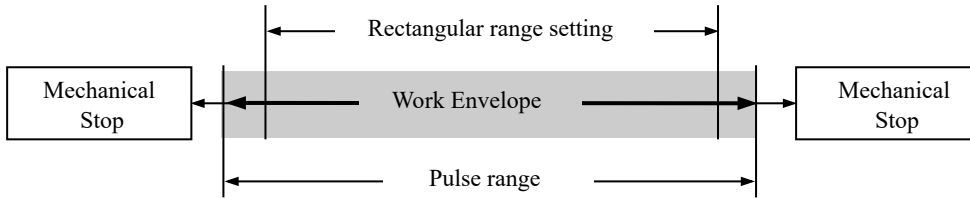

When the motion range is changed due to layout efficiency or safety, follow the descriptions below.

- [Motion Range Setting by Pulse Range](#)
- [Motion Range Setting by Mechanical Stops](#)
- [Setting the Cartesian \(Rectangular\) Range in the XY Coordinate System of the](#)

### 3.5.1 Motion Range Setting by Pulse Range

Pulses are the basic unit of Manipulator motion. The motion range of the Manipulator is controlled by the pulse range between the pulse lower limit and upper limit of each joint. Pulse values are read from the encoder output of the servo motor.

For the maximum pulse range, refer to the following sections. The pulse range must be set inside of the mechanical stop range.

- [Max. Pulse Range of Joint #1](#)
- [Max. Pulse Range of Joint #2](#)
- [Max. Pulse Range of Joint #3](#)
- [Max. Pulse Range of Joint #4](#)

 **KEY POINTS**

Once the Manipulator receives an operating command, it checks whether the target position specified by the command is within the pulse range before operating. If the target position is out of the set pulse range, an error occurs and the Manipulator does not move.



The pulse range can be set on the [Range] panel shown by selecting [Tools]-[Robot Manager]. (You may also execute the Range command from the [Command Window].)

#### 3.5.1.1 Max. Pulse Range of Joint #1

The 0 (zero) pulse position of Joint #1 is the position where Arm #1 faces toward the positive (+) direction on the X-coordinate axis. With the 0 pulse as a starting point, the counterclockwise pulse value is defined as the positive (+) and the clockwise pulse value is defined as the negative (-).

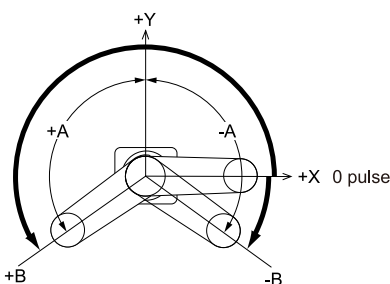

A: Max. Motion Range	B: Max. Pulse Range
±132°	-152918 to 808278 pulse

### 3.5.1.2 Max. Pulse Range of Joint #2

The 0 (zero) pulse position of Joint #2 is the position where Arm #2 is in-line with Arm #1. (Same for all direction of Arm #1)  
 With the 0 pulse as a starting point, the counterclockwise pulse value is defined as the positive (+) and the clockwise pulse value is defined as the negative (-).

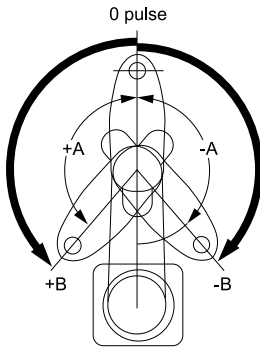

A: Max. Motion Range	B: Max. Pulse Range
±152 °	±345885 pulse

### 3.5.1.3 Max. Pulse Range of Joint #3

The 0 (zero) pulse position of Joint #3 is the position where the shaft is at its upper limit. The pulse value is always negative because Joint #3 always moves lower than the 0 pulse position.

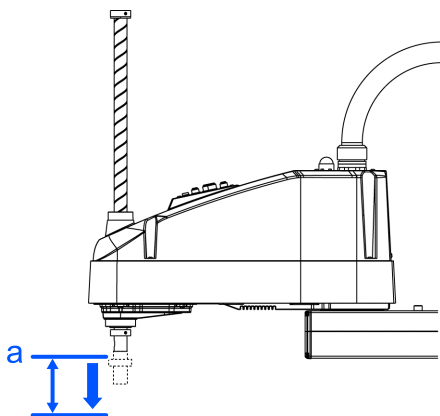

Symbol	Description
a	Upper limit: 0 pulse

	Joint #3 stroke	Lower Limit Pulse
LS20-C804S (Standard model)	420 mm	-283853 pulse
LS20-CA04S (Standard model)		

LS20-C804C (Cleanroom model)	390 mm	-263578 pulse
LS20-CA04C (Cleanroom model)		

**KEY POINTS**

The motion range setting cannot be changed by Joint #3 mechanical stop.

### 3.5.1.4 Max. Pulse Range of Joint #4

The 0 (zero) pulse position of Joint #4 is the position where the flat near the end of the shaft faces toward the end of Arm #2. (Same for all directions of Arm #2) With the 0 pulse as a starting point, the counterclockwise pulse value is defined as the positive (+) and the clockwise pulse value is defined as the negative (-).

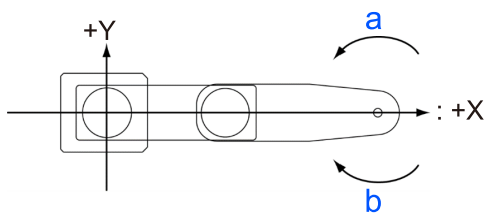

Symbol	Description
a	+ direction
b	- direction

Maximum Pulse Range: 0±344065 pulse

### 3.5.2 Motion Range Setting by Mechanical Stops

Mechanical stops physically limit the absolute area that the Manipulator can move.

Joints #1 and #2 have threaded holes in the positions corresponding to the angle for the mechanical stop settings. Set the motion range depending on the position of the mechanical stop (adjustable) Install the bolts in the holes corresponding to the angle that you want to set.

\*The operating area of the Joint #3 cannot be set.

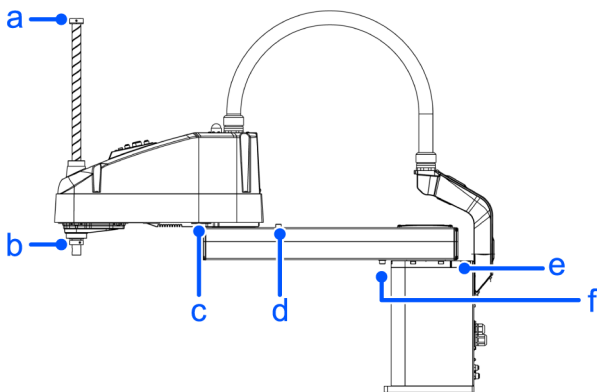

Symbol	Description
a	Mechanical stop of Joint #3 (Lower limit mechanical stop): Do not move the position.

Symbol	Description
b	Mechanical stop of Joint #3 (Upper limit mechanical stop): Do not move the position.
c	Mechanical stop of Joint #2 (Fixed)
d	Mechanical stop of Joint #2 (Adjustable)
e	Mechanical stop of Joint #1 (Fixed)
f	Mechanical stop of Joint #1 (Adjustable)

### 3.5.2.1 Setting the Mechanical Stops of Joints #1 and #2

Joints #1 and #2 have threaded holes in the positions corresponding to the angle for the mechanical stop settings. Set the motion range depending on the position of the mechanical stop (adjustable) Install the bolts in the holes corresponding to the angle that you want to set.

Install the bolts for the mechanical stop to the following position.

#### Joint #1 Mechanical Stops

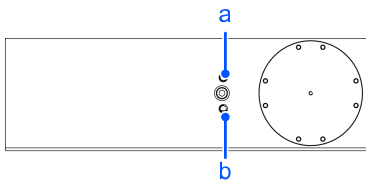

	a	b
Setting Angle (°)	122	-122
Pulse Value (pulse)	771868	-116508

#### Joint #2 Mechanical Stops

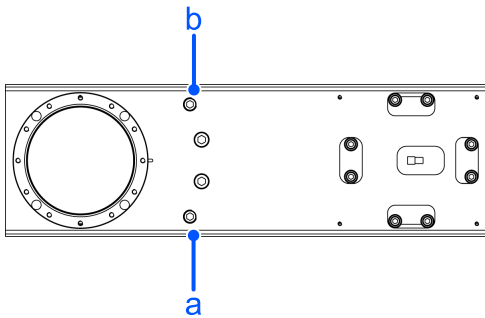

This is a figure of Arm #1 viewed from below.

	a	b
Setting Angle (°)	135	-135
Pulse Value (pulse)	307200	-307200

1. Turn off the Controller.
2. Install a hexagon socket head cap bolt into the hole corresponding to the setting angle, and tighten it.

Joint	Hexagon socket head cap bolt	The number of bolts	Recommended tightening torque	Strength
1	M8×10 full thread	1 bolt / side	13.0 N·m (132.7 kgf·cm)	ISO898-1 property class 10.9 or 12.9.
2	M10×50 full thread			

3. Turn ON the Controller.

4. Set the pulse range corresponding to the new positions of the mechanical stops.

Be sure to set the pulse range inside the positions of the mechanical stop range.

Example: Using LS20-C804S to set Joint #1 from -110 to +110° and Joint #2 from -120 to +120°

Epson  
RC+

Execute the following commands from the [Command Window].

```
>JRANGE 1, -72817, 728177 ' Sets the pulse range of Joint #1
>JRANGE 2, -273066, 273066 ' Sets the pulse range of Joint #2
>RANGE ' Checks the set value using Range command
-72817, 728177, -273066, 273066, -283853, 0, -344064, 344064
```

5. Move the arm by hand until it touches the mechanical stops, and make sure that the arm does not hit any peripheral equipment during operation.

6. Operate the joint changed at low speeds until it reaches the positions of the minimum and maximum pulse range. Make sure that the arm does not hit the mechanical stops.

(Check the position of the mechanical stop and the motion range you set.)

Example: Using LS20-C804S to set Joint #1 from -110 to +110° and Joint #2 from -120 to +120°

Epson  
RC+

Execute the following commands from the [Command Window].

```
>MOTOR ON ' Turns On the motor
>POWER LOW ' Enters low-power mode
>SPEED 5 ' Sets at low speed
>PULSE 1, -72817.0, 0.0 ' Moves to the min. pulse position of Joint #1
>PULSE 728177,0,0,0 ' Moves to the max. pulse position of Joint #1
>PULSE 2, -273066.0, 0 ' Moves to the min. pulse position of Joint #1
>PULSE 327680,273066,0,0 ' Moves to the max. pulse position of Joint #2
```

The Pulse command (Go Pulse command) moves all joints to the specified positions at the same time. Specify safe positions after considering motion of not only the joints whose pulse range have been changed, but also other joints.

In this example, when checking Joint #2, Joint #1's setting is set to 0° near the center of the motion area (pulse: 327680) and then operated.

If the arm is hitting the mechanical stops or if an error occurs after the arm hits the mechanical stops, either reset the pulse range to a narrower setting or extend the positions of the mechanical stops within the limit.

### 3.5.3 Setting the Cartesian (Rectangular) Range in the XY Coordinate System of the

Manipulator (for Joints #1 and #2)

Use this method to set the upper and lower limits of the X and Y coordinates.

This setting is only enforced by software. Therefore, it does not change the physical range. The maximum physical range is based on the position of the mechanical stops.



Set the XYLim setting on the [XYZ Limits] panel shown by selecting [Tools]-[Robot Manager]. (You may also execute the XYLim command from the [Command Window].)

### 3.5.4 Standard Motion Range

#### Motion Range

The following “motion range” diagrams show the standard (maximum) specification. When each Joint motor is under servo control, the center of Joint #3’s (shaft’s) lowest point moves in the areas shown in the figure.

#### Area limited by a mechanical stop

The area where the center of Joint #3’s lowest point can be moved when each joint motor is not under servo control.

#### Mechanical stop

The area that contains the farthest reach of the arms.

#### Maximum Range

The area that contains the farthest reach of the arms. If the maximum radius of the end effector is over 60 mm, add the “Area limited by mechanical stop” and “radius of the end effector” as the maximum area.

A	Center of Joint #3
B	Motion Range
C	Maximum Range
D	Base mounting face
E	Area limited by a mechanical stop

		LS20-C804 *	LS20-CA04*
a	Arm #1 + Arm #2 [mm]	800	1000
b	Arm 1 length [mm]	350	550
c	Arm 2 length [mm]	450	
d	Joint #1 motion range [°]	132	
e	Joint #2 motion range [°]	152	
f	(Motion range)	216.5	260.7

		LS20-C804 *	LS20-CA04*
g	(Motion range of the back side)	684.2	818
h	Angle to the mechanical stop of Joint #1 [°]	2.0	
i	Angle to the mechanical stop of Joint #2 [°]	3.6	
j	(Mechanical stop area)	195.3	232.8
k	(Mechanical stop area on the back side)	693.1	832.1
m	(Joint #3 motion range)	LS20-C***S	420
		LS20-C***C	390
n	(Distance from the base mounting face)	LS20-C***S	26.5
		LS20-C***C	33.7
p	(Joint #3 Mechanical stop area, upper terminal)	LS20-C***S	6.5
		LS20-C***C	3.2
q	(Joint #3 Mechanical stop area, lower terminal)	LS20-C***S	8.5
		LS20-C***C	1.3

**Standard environment specification**

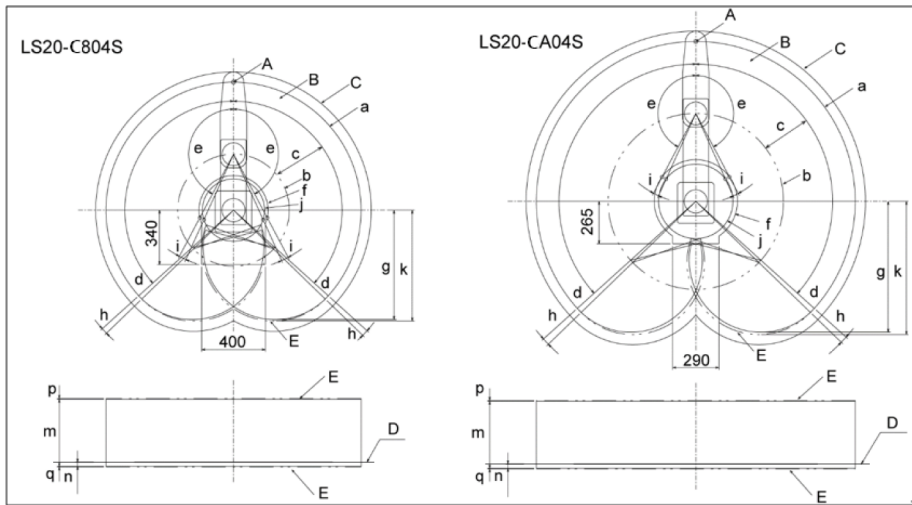

**Cleanroom Environment Specification**

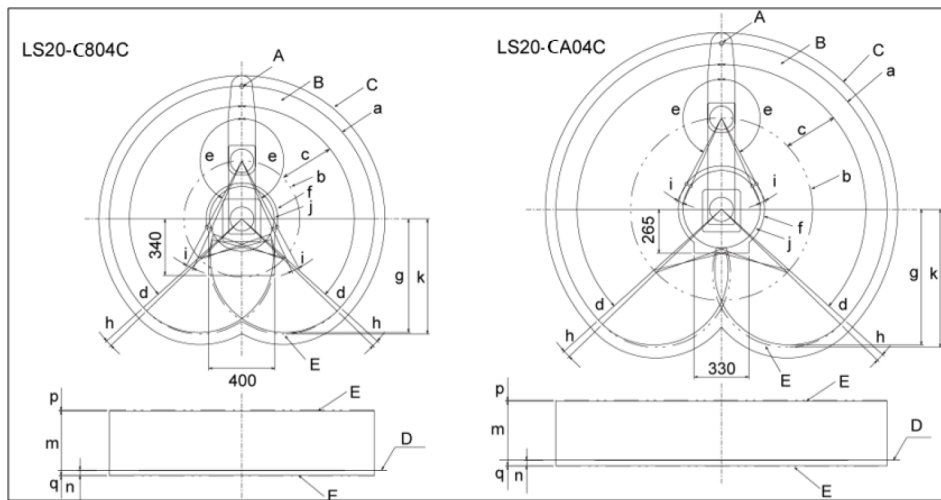

## **4. LS50-C Manipulator**

This volume contains information for setup and operation of the Manipulators.

Please read this volume thoroughly before setting up and operating the Manipulators.

## 4.1 Safety

The Manipulator and its related equipment should be unpacked and transported by people who have received installation training provided by Epson and the suppliers. Also, the laws and regulations of the installation country must be followed.

Before use, please read this manual and other related manuals to ensure correct use. After reading this manual, store it in an easily accessible location for future reference.

This product is intended for transporting and assembling parts in a safely isolated area.

### 4.1.1 Conventions

The following symbols are used in this manual to indicate important safety information. Be sure to read the descriptions shown with each symbol.

#### WARNING

This symbol indicates an imminently hazardous situation which, if operation is not performed properly, will result in death or serious injury.

#### WARNING

This symbol indicates a potentially hazardous situation which, if operation is not performed properly, could result in an injury due to electric shock.

#### CAUTION

This symbol indicates a potentially hazardous situation which, if operation is not performed properly, may result in a minor or moderate injury or in property damage only.

### 4.1.2 Design and Installation Safety

This product is intended for transporting and assembling parts in a safely isolated area.

Design and installation of robot system shall be performed by personnel who has taken robot system training held by us and suppliers.

To ensure safety, a safeguard must be installed for the robot system. For details on the safeguard, refer to the following.

#### Safeguard

The following items are safety precautions for design personnel.

#### WARNING

- Personnel who design and/or construct the robot system with this product must read the “Safety Manual” to understand the safety requirements before designing and/or constructing the robot system. Designing and/or constructing the robot system without understanding the safety requirements is extremely hazardous, may

result in serious bodily injury and/or severe equipment damage to the robot system, and may cause serious safety problems.

- The Manipulator and the Controller must be used within the environmental conditions described in their respective manuals. This product has been designed and manufactured strictly for use in a normal indoor environment. Using the product in an environment that exceeds the specified environmental conditions may not only shorten the life cycle of the product but may also cause serious safety problems.
- The robot system must be used within the installation requirements described in the manuals. Using the robot system outside of the installation requirements may not only shorten the life cycle of the product but also cause serious safety problems.
- When designing or installing a robot system, wear at least the following protective gear. Working without protective gear may cause serious safety problems.
  - Work clothes suitable for work
  - Helmet
  - Safety shoes

Further precautions for installation are mentioned in the following.

**Environment and Installation**

Please read this chapter carefully to understand safe installation procedures before installing the robots and robotic equipment.

**4.1.2.1 Strength of the Ball Screw Spline**

If a load exceeding the allowable value is applied to the ball screw spline, it may not work properly due to deformation or breakage of the shaft.

If the ball screw spline is applied the load exceeding the allowable value, it is necessary to replace the ball screw spline unit. The allowable loads differ depending on distance where the load is applied to. For calculating the allowable load, see the calculation formula below.

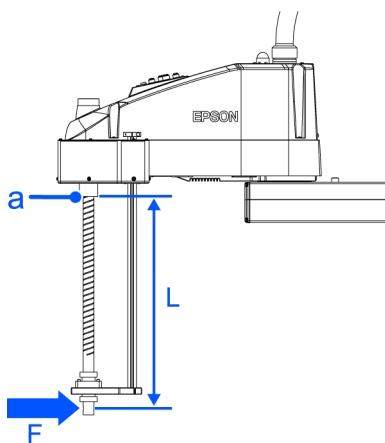

Symbol	Description
a	End of the spline nut

**Example:**

If 110 N (11.2kgf) load is applied at 400 mm from the end of the spline nut

**Allowable bending moment**

$M=80,000 \text{ N}\cdot\text{mm}$

## Moment

$$M=F \cdot L = 100 \cdot 400 = 44,000 \text{ N} \cdot \text{mm}$$

### 4.1.3 Operation Safety

The following items are safety precautions for qualified Operator personnel:

#### WARNING

- Please carefully read the Safety Requirements in the “Safety Manual” before operating the robot system. Operating the robot system without understanding the safety requirements is extremely hazardous and may result in serious bodily injury and/or severe equipment damage to the robot system.
- Do not enter the operating area of the Manipulator while the power to the robot system is turned ON. Entering the operating area with the power ON is extremely hazardous and may cause serious safety problems as the Manipulator may move even if it seems to be stopped.
- Before operating the robot system, make sure that no one is inside the safeguarded area. The robot system can be operated in the mode for teaching even when someone is inside the safeguarded area. The motion of the Manipulator is always in restricted (low speed and low power) status to secure the safety of an operator. However, operating the robot system while someone is inside the safeguarded area is extremely hazardous and may result in serious safety problems in case that the Manipulator moves unexpectedly.
- Immediately press the Emergency Stop switch whenever the Manipulator moves abnormally while the robot system is operated. Continuing the operation while the Manipulator moves abnormally is extremely hazardous and may result in serious bodily injury and/or severe equipment damage to the robot system.

#### WARNING

- To shut off power to the robot system, disconnect the power plug from the power source or use a disconnecter. Be sure to connect the AC power cable to either a power receptacle or a disconnecter. DO NOT connect it directly to a factory power source.
- Before performing any replacement procedure, turn OFF the Controller and related equipment, and then disconnect the power plug from the power source. Performing any replacement procedure with the power ON is extremely hazardous and may result in electric shock and/or malfunction of the robot system.
- Do not connect or disconnect the motor connectors while the power to the robot system is turned ON. Connecting or disconnecting the motor connectors with the power ON is extremely hazardous and may result in serious bodily injury as the Manipulator may move abnormally. Performing any work procedure with the power turned on is extremely dangerous and may result in electric shock and/or malfunction of the robot system.

#### CAUTION

- Whenever possible, only one person should operate the robot system. If it is necessary to operate the robot system with more than one person, ensure that all people involved communicate with each other as to what they are doing and take all necessary safety precautions.
- Joint #1, #2, and #4: If the joints are operated repeatedly with the operating angle less than 5 degrees, the bearings are likely to cause oil film shortage in such situation. Repeating the operation may cause the

Manipulator to break faster. To prevent early breakdown, move each joint larger than 50 degrees for about once an hour.

- Joint #3: If the up-and-down motion of the hand is less than 50 mm, move the joint a half of the maximum stroke for about once an hour.
- Vibration (resonance) may occur continuously in low speed Manipulator motion (Speed: approx. 5 to 20%) depending on combination of Arm orientation and end effector load. Vibration arises from natural vibration frequency of the Arm and can be controlled by following measures.
  - Changing Manipulator speed
  - Changing the teach points
  - Changing the end effector load

## 4.1.4 Emergency Stop

Each robot system needs equipment that will allow the operator to immediately stop the system's operation. Install an emergency stop device by using emergency stop input from the Controller or other equipment.

Before using the emergency stop switch, be aware of the following points.

- The emergency stop switch should be used to stop the Manipulator only in case of emergencies.
- Besides pressing the emergency stop switch when an emergency occurs, to stop the Manipulator during program operation, use the Pause or STOP (program stop) statements assigned to a standard I/O.  
The Pause and STOP statements do not turn off motor energization, and so the brake is not locked.

To place the robot system in emergency stop mode in a non-emergency (normal) situation, press the emergency stop switch while the Manipulator is not operating.

Do not press the emergency stop switch unnecessarily while the Manipulator is operating normally.

It could shorten the lifespan of the following components.

- Brakes  
The brakes will be locked, which will shorten the lifespan of the brakes due to worn brake friction plates.
  - Normal brake lifespan:  
About 2 years (when the brakes are used 100 times/day)  
or about 20,000 times
- Reduction gears  
An emergency stop applies an impact to the reduction gear, which can shorten its life.

If the Manipulator is stopped by turning off the Controller while it is operating, the following problems may occur.

- Reduced life and damage to reduction gear
- Position shift at the joints

If a power outage or other unavoidable Controller power-off occurs during Manipulator operation, check the following points after power is restored.

- Damage in reduction gear
- Shifting of the joints from their proper positions

If there was any shifting, maintenance is required. For more information, please contact the supplier.

### Stopping distance of emergency stop

The Manipulator during operation cannot stop immediately after the emergency stop switch is pressed. Also, the stopping time and movement distance vary depending on the following factors.

- Hand weight, WEIGHT setting, ACCEL setting, workpiece weight, SPEED setting, movement posture, etc.

For the stopping time and movement distance of the Manipulator, refer to the following section.

### Appendix C: Stopping time and Stopping distance in Emergency

#### 4.1.5 Safeguard

To maintain a safe working zone, safety barriers must be set up around the Manipulator, and safeguards must be installed at the entrance and exit of the safety barriers.

The term "safeguard" as used in this manual refers to a safety device with an interlock that allows entry into the safety barriers. Specifically, this includes safety door switches, safety barriers, light curtains, safety gates, safety floor mats, and so on. The safeguard is an input that informs the Robot Controller that an operator may be inside the safeguard area. You must assign at least one Safeguard (SG) in Safety Function Manager.

When the safeguard is opened, Protective Stop operates to change to the safeguard open state (display: SO).

- Safeguard open  
Operations are prohibited. Further robot operation is not possible until either the safeguard is closed, the latched state is released, and a command is executed, or the TEACH or TEST operation mode is turned on and the enable circuit is activated.
- Safeguard closed  
The robot can operate automatically in an unrestricted (high power) state.

#### WARNING

- If a third party accidentally releases the safeguard while an operator is working inside the safety barriers, this may result in a hazardous situation. To protect the operator working inside the safety barriers, implement measures to lock out or tag out the latch release switch.
- To protect operators working near the robot, be sure to connect a safeguard switch and make sure that it works properly.

#### Installing safety barriers

When installing safety barriers within the maximum range of the Manipulator, combine safety functions such as SLP. Carefully take into account the size of the hand and the workpieces to be held so that no interference occurs between the operating parts and the safety barriers.

#### Installing safeguards

Design the safeguards so that they satisfy the following requirements:

- When using a key switch type safety device, use a switch that forcibly opens the interlock contacts. Do not use switches that open their contacts using the spring force of the interlock.
- When using an interlock mechanism, do not disable the interlock mechanism.

#### Considering the stopping distance

During operation, the Manipulator cannot stop immediately even if the safeguard is opened. Also, the stopping time and movement distance vary depending on the following factors.

- Hand weight, WEIGHT setting, ACCEL setting, workpiece weight, SPEED setting, movement posture, etc.

For the stopping time and movement distance of the Manipulator, refer to the following section.

**Appendix D: Stopping time and Stopping distance when Safeguard is Opened**

**Precautions for safeguard operation**

Do not open the safeguard unnecessarily while the motor is energized. Frequent safeguard inputs will reduce the life of the relay.

- Normal relay lifespan: Approximately 20,000 times

**4.1.6 Emergency Movement without Drive Power**

When the system is placed in emergency mode, push the arm or joint of the Manipulator by hand as shown below:

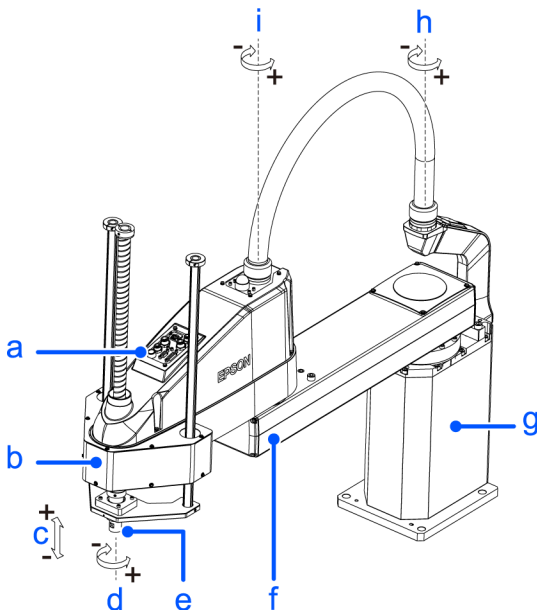

(Figure: LS50-CA04S)

Symbol	Description
a	Joint #3 #4 Brake release switch
b	Arm #2
c	Joint #3 (up and down)
d	Joint #4 (rotating)
e	Shaft
f	Arm #1
g	Base
h	Joint #1 (rotating)
i	Joint #2 (rotating)

- Arm #1: Push the arm by hand.
- Arm #2: Push the arm by hand.
- Joint #3: The joint cannot be moved up/down by hand until the electromagnetic brake applied to the joint has been released. Move the joint up/down while pressing the brake release switch.

- Joint #4: The shaft cannot be rotated by hand until the electromagnetic brake applied to the shaft has been released. Move the joint up/down while pressing the brake release switch.

**⚠ CAUTION**

The brake release switch is used with both Joint #3 and Joint #4. When the brake release switch is pressed in emergency mode, the brake for both Joints #3 and #4 are released simultaneously. Be careful of getting caught in Joint #3 and 4 operating range due to the shaft falling and rotating while the brake release switch is being pressed because the shaft may be lowered by the weight of the hand.

**4.1.7 ACCELS Setting for CP Motions**

To make the Manipulator move in a CP motion, make the appropriate ACCELS settings in the SPEL program based on the tip load and Z-axis height.

**✍ KEY POINTS**

If the ACCELS settings are not properly configured, the following problem occurs.

- Shortened lifespan and damage to the ball screw spline
- Stop with error (Error code: 4002)

Set ACCELS as shown below based on the Z-axis height.

**Maximum ACCELS correction values by Z-axis height and tip load**

Z-axis height(mm)	Tip load		
	30kg or less	40kg or less	50kg or less
0>Z≥-400	14000 or less	5000 or less	5000 or less

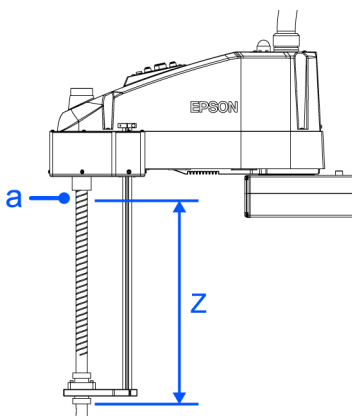

Symbol	Description
a	Z-axis height 0 (Origin position)

If the Manipulator is operated in CP motion with the wrong set values, make sure to check the following.

- Whether or not the ball screw spline shaft is deformed or bent

### 4.1.8 Warning Labels

The Manipulator has the following warning labels. Specific hazards exist in the vicinity of areas with the warning labels. Be thoroughly careful in handling. To ensure that the Manipulator is operated and maintained safely, be sure to follow the safety information and warnings indicated on the warning labels. Also, do not tear, damage, or remove these warning labels.

A



Touching any internal electrified parts while the power is turned on may cause electric shock.

B



The surface of the Manipulator is very hot during and after operation which can cause for you to get burnt.

1

This indicates the product name, model name, serial number, information of supported laws and regulations, product specifications, manufacturer, importer, date of manufacture, country of manufacture, and the like.

For details, see the label affixed to the product.

2



Indicates the position of the brake release switch



Indicates the position of a threaded hole for an eye bolt mounting screw.

**LS50-C**

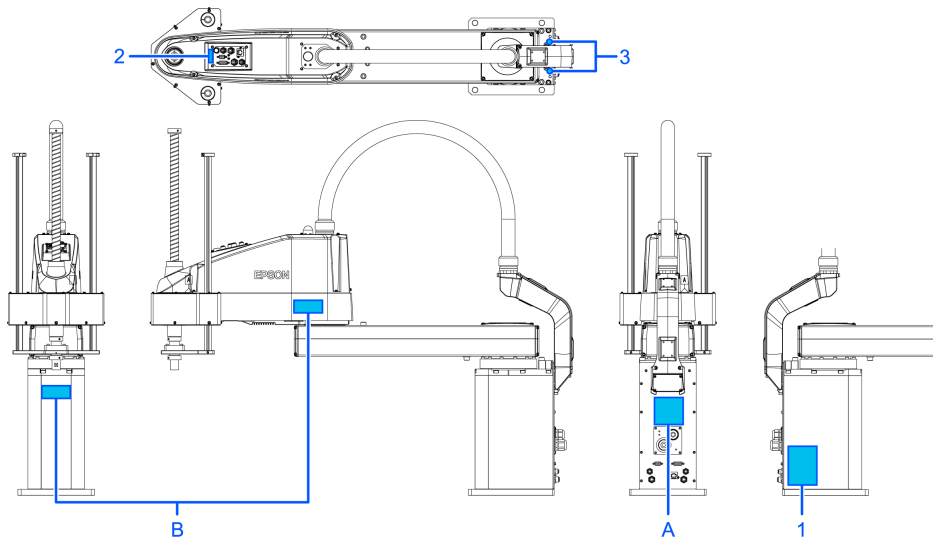

**4.1.9 Response for Emergency or Malfunction**

**4.1.9.1 Collision**

If the Manipulator has collided with a mechanical stop, peripheral device, or other object, discontinue use and contact the supplier.

Also, if the Manipulator collides with mechanical stops or peripheral devices, the following problems may occur.

- Reduction of the life and damage of the reduction gear unit
- Position gap at the joints

**4.1.9.2 Getting body caught in Manipulator**

When the operator is caught between the Manipulator and a mechanical part such as a base table, press the emergency stop switch to release the brake on the subject arm, and then move the arm by hand.

- Get body caught in the arms:
  - The break is not working. Move the arms manually.
- Get body caught in the shafts:
  - The break is working. Press the brake release switch and move the shafts.

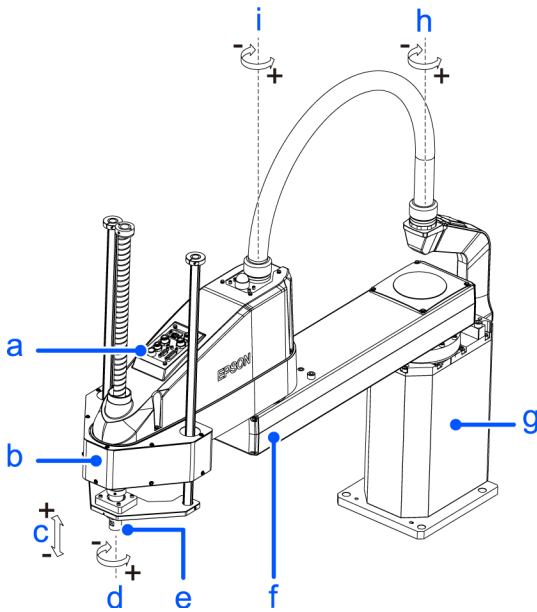

(Figure: LS50-CA04S)

Symbol	Description
a	Joint #3 #4 Brake release switch
b	Arm #2
c	Joint #3 (up and down)
d	Joint #4 (rotating)
e	Shaft
f	Arm #1
g	Base
h	Joint #1 (rotating)
i	Joint #2 (rotating)

**⚠ CAUTION**

Be careful of the shaft falling and rotating while the brake release switch is being pressed because the shaft may be lowered by the weight of the hand.

## 4.2 Specification

### 4.2.1 Model number

LS50-CA 0 □ S  
 [a] [b] [c][d]

- a: Payload
  - 50: 50 kg

- b: Arm length
  - A0: 1000 mm
- c: Joint #3 stroke
  - 2: 210 mm
  - 4: 400 mm
- D: Environment
  - S: Standard

For details on the specifications, refer to the following.

**Appendix B: Specification Table**

**List of Models**

Payload	Arm length	Environment	Joint #3 stroke	Model number
50 kg	1000 mm	Standard	210 mm	LS50-CA02S
			400 mm	LS50-CA04S

**4.2.2 Part Names and Outer Dimensions**

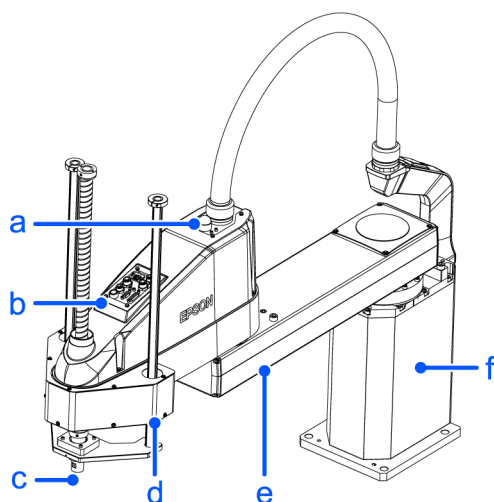

Symbol	Description
a	LED lamp
b	Joint #3 Brake release switch
c	Shaft
d	Arm #2
e	Arm #1
f	Base

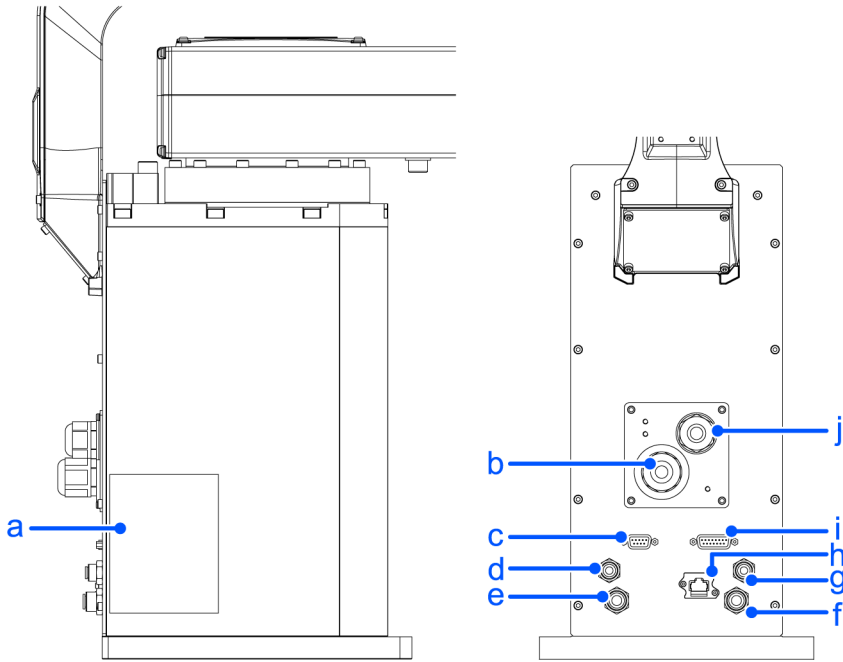

Symbol	Description
a	Signature label (Serial No. of Manipulator)
b	Power cable
c	User connector (9-pin D-sub connector)
d	Fittings for $\varnothing 6$ mm pneumatic tube (No.1)
e	Fittings for $\varnothing 8$ mm pneumatic tube (No.2)
f	Fittings for $\varnothing 8$ mm pneumatic tube (No.3)
g	Fittings for $\varnothing 6$ mm pneumatic tube (No.4)
h	Ethernet connector
i	User connector (15-pin D-sub connector)
j	Signal Cable

**KEY POINTS**

- The brake release switch affects both Joints #3 and #4. When the brake release switch is pressed in emergency mode, the brake for both Joints #3 and #4 are released simultaneously.
- While the LED lamp is on, current is being applied to the Manipulator. Performing any work with the power ON is extremely hazardous and may result in electric shock and/or malfunction of the robot system. Make sure to turn OFF the controller power before maintenance work.

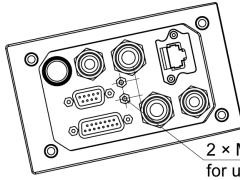
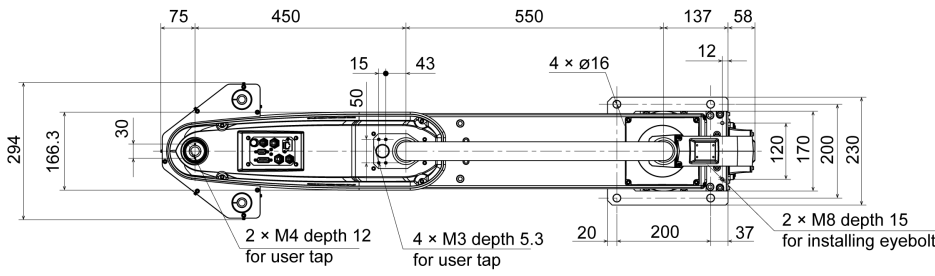

Detail of D

2 x M3 depth 3.5 for user tap

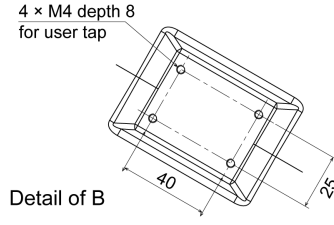

Detail of B

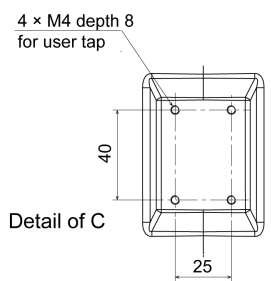

Detail of C

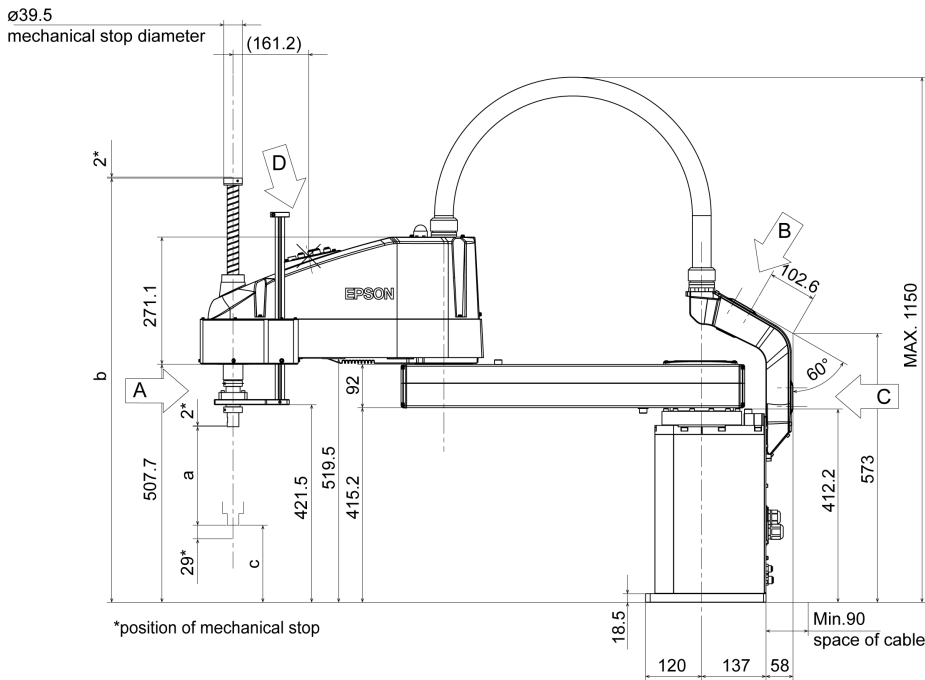

\*position of mechanical stop

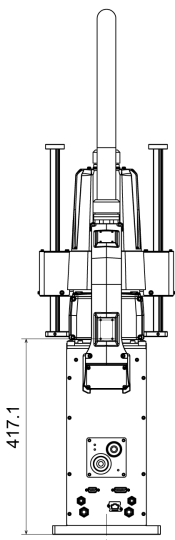

417.1

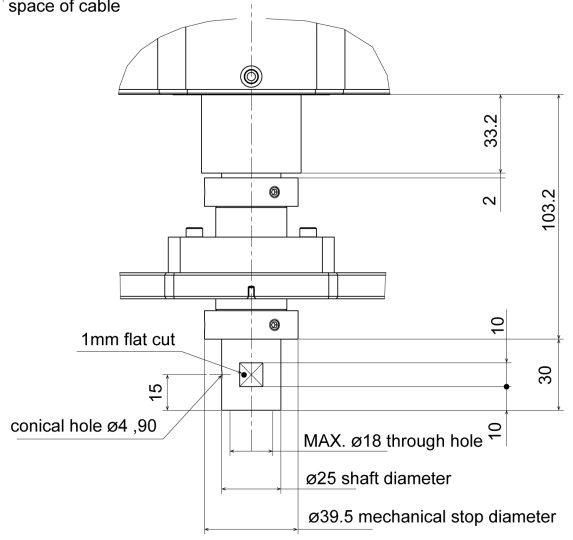
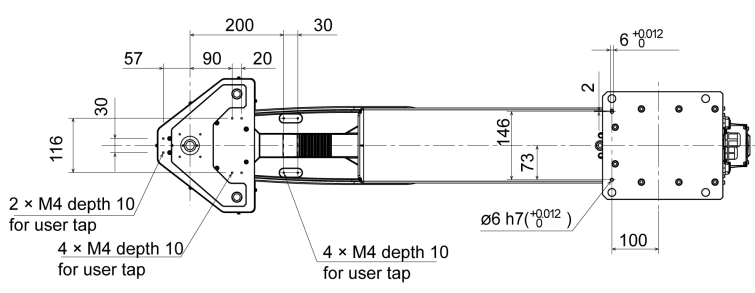

Detail of A

	LS50-CA02S	LS50-CA04S
a	210	400
b	904.5	1094.5

	LS50-CA02S	LS50-CA04S
c	164.5	-25.5

### 4.2.3 Specification table

For details on the specifications of each model, refer to the following:

[Appendix B: Specification Table](#)

### 4.2.4 How to Set the Model

The Manipulator model for your system has been set before shipment from the factory.

#### CAUTION

- If changing the setting of the Manipulator model, be responsible and absolutely certain that the wrong Manipulator model is not set. Incorrect setting of the Manipulator model may result in abnormal or no operation by the Manipulator and could even cause safety problems.

If a custom specifications number (MT\*\*\*\*) or (X\*\*\*\*) is written on the face plate (serial number label), the Manipulator has custom specifications.

Models with custom specifications may require a different setting procedure. Check the custom specifications number, and contact the supplier for more information.

The Manipulator model is set from software. For details, refer to the following manual.  
"Epson RC+ User's Guide - Robot Configuration"

## 4.3 Environment and Installation

The robot system should be designed and installed by people who have received installation training provided by Epson and the suppliers. Also, the laws and regulations of the installation country must be followed.

### 4.3.1 Environment

A suitable environment is necessary for the robot system to function properly and safely. Be sure to install the robot system in an environment that meets the following conditions:

Item	Conditions
Ambient Temperature *	5 to 40°C
Ambient relative humidity	10 to 80 % (no condensation)
Fast transient burst noise	1 kV or less (Signal wire)
Electrostatic noise	4 kV or less
Altitude	1000 m or lower

Item	Conditions
Environment	<ul style="list-style-type: none"> <li>▪ Install indoors</li> <li>▪ Keep away from direct sunlight</li> <li>▪ Keep away from dust, oily smoke, salinity, metal powder and other contaminants</li> <li>▪ Keep away from flammable or corrosive solvents and gases</li> <li>▪ Keep away from water</li> <li>▪ Keep away from shock or vibration</li> <li>▪ Keep away from sources of electric noise</li> <li>▪ Keep away from explosive area</li> <li>▪ Keep away from a large quantity of radiation</li> </ul>

\* The ambient temperature conditions are for the Manipulator only. For the Controller the Manipulators are connected to, refer to the Controller Manual.

 **KEY POINTS**

---

- Manipulators are not suitable for operation in harsh environments such as painting areas, etc. When using Manipulators in inadequate environments that do not meet the above conditions, please contact the supplier of your region.
- When the product is used in a low temperature environment around the minimum temperature of the product specification, or when the product is suspended for a long time on holidays or at night, a collision detection error may occur due to the large resistance of the drive unit immediately after the start of operation. In such case, it is recommended to warm up for about 10 minutes.

**Special Environmental Conditions**

The surface of the Manipulator has general oil resistance. However, if your requirements specify that the Manipulator must withstand certain kinds of oil, please contact the supplier of your region.

Rapid change in temperature and humidity can cause condensation inside the Manipulator.

If your requirements specify that the Manipulator handles food, please contact the supplier of your region to check whether the Manipulator will damage the food or not.

The Manipulator cannot be used in corrosive environments where acid or alkaline is used. In a salty environment where the rust is likely to gather, the Manipulator is susceptible to rust.

 **WARNING**

---

- Always use a circuit breaker for the Controller's power supply. Failure to use a circuit breaker may result in an electrical shock hazard or malfunction due to an electrical leakage. Select the correct circuit breaker based on the Controller that you are using. For details, refer to the following manual.

"Robot Controller Manual"

**⚠ CAUTION**

- When cleaning the Manipulator, do not rub it strongly with alcohol or benzene. Coated surfaces may lose their luster.

**4.3.2 Base Table**

Please make or obtain the base table to secure your Manipulator.

The shape and size of the base table differs depending on the use of the robot system. For your reference, we list some Manipulator table requirements here.

The base table must not only be able to bear the weight of the Manipulator but also be able to withstand the dynamic movement of the Manipulator when it operates at maximum acceleration/deceleration. Ensure that there is enough strength on the base table by attaching reinforcing materials such as crossbeams.

The torque and reaction force produced by the movement of the Manipulator are as follows:

	LS50-C
Max. reaction torque on the horizontal plate	1700 N·m
Max. horizontal reaction force	4400 N
Max. vertical reaction force	4600 N

**⚠ CAUTION**

If the vibration of the base table is large, reduce the acceleration/deceleration or increase the rigidity of the base table to reduce the vibration. Continued use in a state of large vibration may cause loosening of fastening parts or excessive load on mechanical parts, which may shorten the lifespan.

The threaded holes required for mounting the Manipulator base are M12. Use mounting bolts with specifications conforming to ISO898-1 property class 10.9 or 12.9. For dimensions, refer to the following.

**Mounting Dimensions**

The plate for the Manipulator mounting face should be 20 mm thick or more and made of steel to reduce vibration. The surface roughness of the steel plate should be 25 μm or less.

The table must be secured on the floor or wall to prevent it from moving.

The Manipulator installation surface should have a flatness of 0.5 mm or less and an inclination of 0.5° or less. If the flatness of the installation surface is improper, the base may be damaged, or the robot may not fully show its performance.

When using a leveler to adjust the height of the base table, use a screw with M16 diameter or more.

If you are passing cables through the holes on the base table, see the figures below.

(Unit : mm)

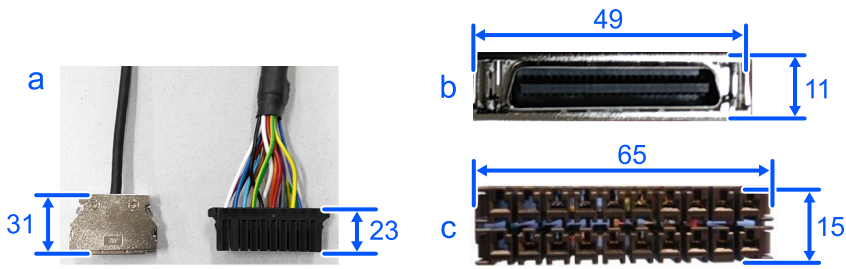

Symbol	Description
a	M/C Cables
b	Signal Cable Connector
c	Power Cable Connector

For environmental conditions regarding space when placing the Controller on the base table, refer to the Controller manual.

**⚠ WARNING**

To ensure safety, a safeguard must be installed for the robot system. For details on the safeguard, refer to the Epson RC+ User's Guide.

**4.3.3 Mounting Dimensions**

The maximum space (R) includes the radius of the end effector. If it exceeds 80 mm, define the radius as the distance to the outer edge of maximum space. If a camera or solenoid valve extends outside of the arm, set the maximum range including the space that they may reach.

Be sure to allow for the following extra spaces in addition to the space required for mounting the Manipulator, Controller, and peripheral equipment.

- Space for teaching
- Space for maintenance and inspection (Ensure a space to open the covers and plates for maintenance.
- Space for cables

**⚠ WARNING**

Install the Manipulator in a place where the the tool or the tip of the workpiece does not reach the wall and safety barriers when the Arm holding the workpiece is stretched.

If the tool or tip of the workpiece touches the wall and safety barriers, it can be extremely hazardous and may result in serious bodily injury and/or severe equipment damage to the robot system.

The distance between the safety barriers and tool or workpiece should be set according to the ISO10218-2.

For details on the stopping time and stopping distance, refer to the following:

[Appendix C: Stopping time and Stopping distance in Emergency](#)

[Appendix D: Stopping time and Stopping distance when Safeguard is Opened](#)

## KEY POINTS

When installing the cable, be sure to maintain sufficient distance from obstacles.

For the minimum bend radius of the MC cable, refer to the following.

### LS50-C Specification Table

For other cables, make sure to secure enough space so as not to bend the cables excessively.

Ensure distance to the safeguard from the maximum motion range is more than 100 mm.

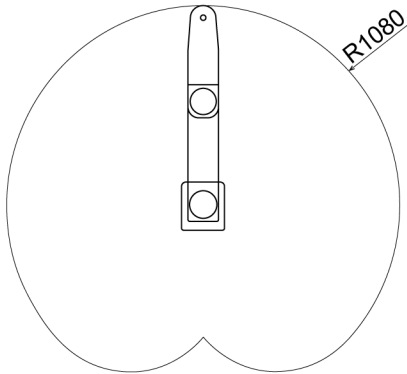

## 4.3.4 Unpacking and Transportation

Transportation and installation of the Manipulators shall be performed by personnel who has taken robot system training held by us and suppliers and should conform to all national and local codes.

### WARNING

- Only authorized personnel should perform sling work and operate a crane and a forklift. When these operations are performed by unauthorized personnel, it is extremely hazardous and may result in serious bodily injury and/or severe equipment damage to the robot system.
- Stabilize the Manipulator with your hands when hoisting it. If you lose balance, the Manipulator may fall which could result in serious bodily injury and/or severe equipment damage.

### CAUTION

- Using a cart or similar equipment, transport the Manipulator in the same manner as it was delivered.
- After removing the bolts securing the Manipulator to the delivery equipment, the Manipulator can fall. Be careful not to get hands or fingers caught.
- The arm is secured with a wire tie. Leave the wire tie secured until you finish the installation so as not to get hands or fingers caught.
- To carry the Manipulator, have two or more people to work on it and secure the Manipulator to the delivery equipment. Also, do not hold the shaded area in the figure. Doing so is extremely dangerous and can result in getting your hands and fingers caught.

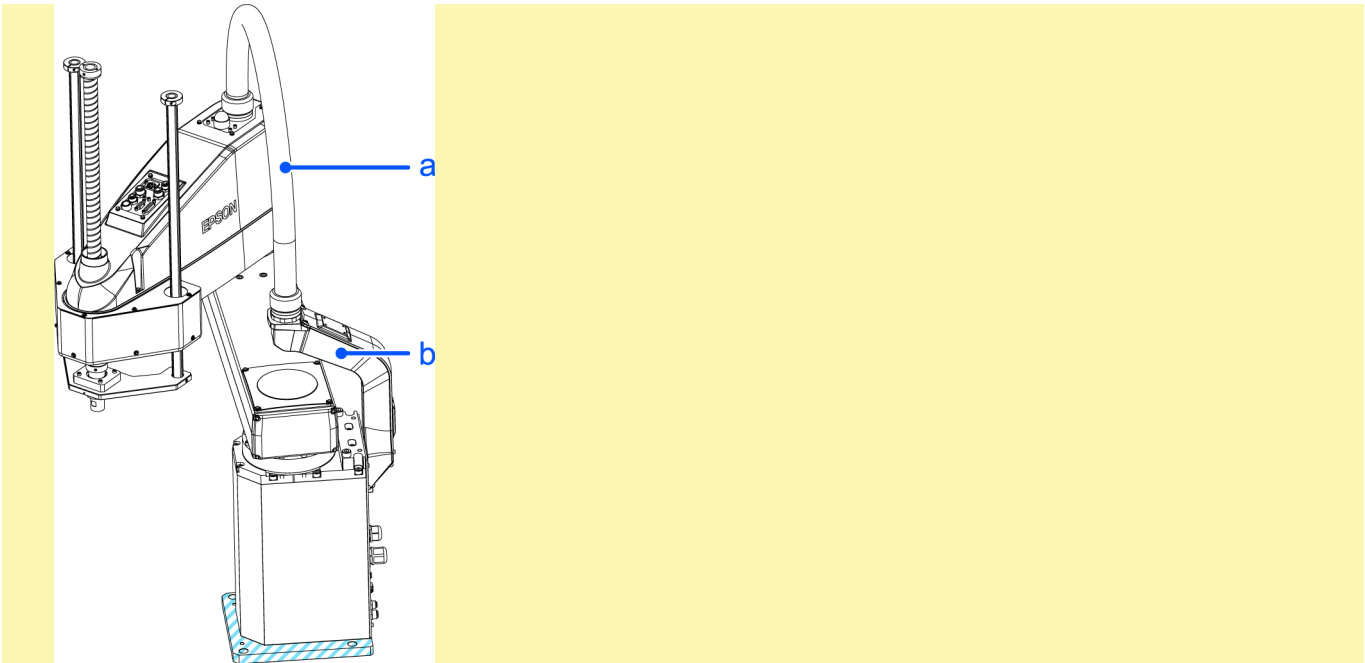

(Figure: LS50-CA04S)

Symbol	Description
a	Resin Duct
b	Metal Duct

- LS50-CA02S: approx. 60 kg: 132.3 lbs. (pound)
- LS50-CA04S: approx. 61 kg: 134.5 lbs. (pound)
- Do not hold the metal duct and the resin duct when transporting the Manipulator. Doing so may damage them.

 **KEY POINTS**

---

When transporting the Manipulator for a long distance, secure it to the delivery equipment directly so that the Manipulator never falls over. If necessary, pack the Manipulator in the same style as it was delivered.

Transport the Manipulator following the instructions below:

1. Attach the eye bolts to the upper side of the Base.
2. Turn the Arm #1 to face the front.
3. Pass the belts through the eye bolts and Arm #2. Set the wire tie at the metal part (shaded area in the figure below) so that the belt cannot move.
4. Hoist the Manipulator slightly so that it does not fall over. Then, remove the bolts securing the Manipulator to the delivery equipment or a pallet.
5. Hoist the Manipulator attaching the hands at the positions indicated by arrows so that it can keep the balance. Then, move the Manipulator to the base table.

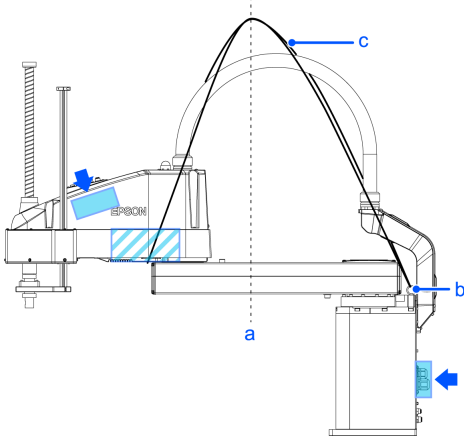

(Figure, LS50-CA04)

Symbol	Description
a	Center of gravity
b	Eye bolts
c	Belt

### 4.3.5 Installation Procedure

Installation of the Manipulators and robotic equipment shall be performed by personnel who has taken robot system training held by us and suppliers and should conform to all national and local codes.

**⚠ CAUTION**

- The robot system must be installed to avoid interference with buildings, structures, utilities, other machines and equipment that may create a trapping hazard or pinch points.
- Vibration (resonance) may occur during operation depending on rigidity of the base table. If vibration occurs, improve rigidity of the table or change the speed or acceleration and deceleration settings
- Install and move the Manipulator with two or more people. The Manipulator weights are as follows. Be careful not to get hands or feet caught and/or have equipment damaged by the Manipulator falling.
  - LS50-CA02S: approx. 60 kg: 132.3 lbs. (pound)
  - LS50-CA04S: approx. 61 kg: 134.5 lbs. (pound)

1. Secure the base to the base table with four bolts.

**✎ KEY POINTS**

Use bolts with specifications conforming to ISO898-1 Property Class 10.9 or 12.9.

Tightening torque: 80.0 N·m (816 kgf·cm)

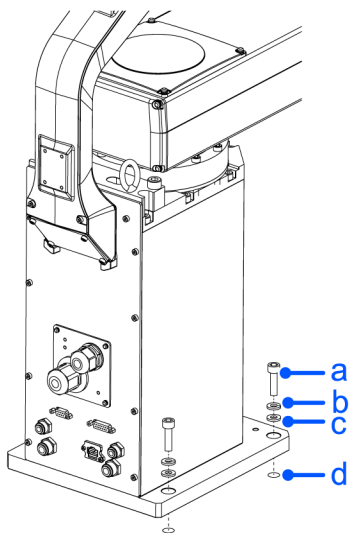

Symbol	Description
a	M12×40
b	Spring Washer
c	Plain Washer
d	Screw Hole

2. Using nippers, cut off the wire tie binding the arm. Remove the bolt.

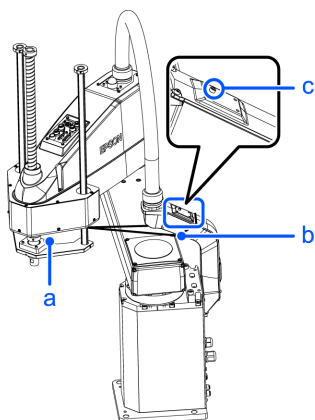

Symbol	Description
a	Eye bolts
b	Wire tie
c	Bolt: M4

3. Using nippers, cut off the Arm securing band #1.

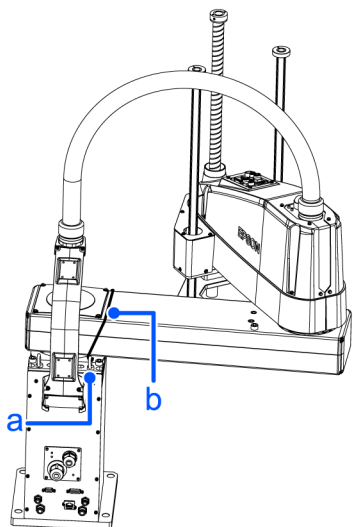

Symbol	Description
a	Eye bolts
b	Arm securing band

- Remove the wire tie and rope protecting the mechanical stop.  
Do not remove the mechanical stop.

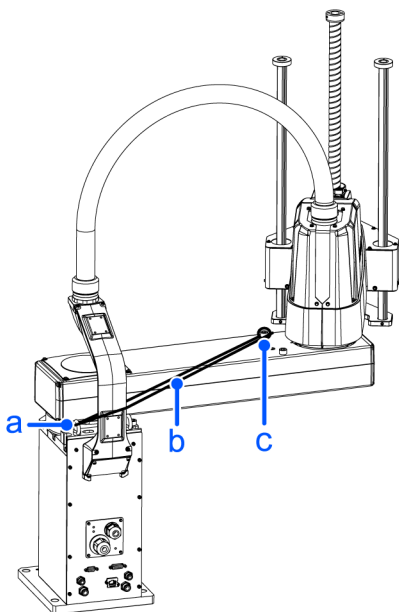

Symbol	Description
a	Eye bolts
b	Rope
c	Wire tie

### 4.3.6 Connecting the Cables

#### WARNING

- To shut off power to the robot system, disconnect the power plug from the power source or use a disconnecter. Be sure to connect the AC power cable to either a power receptacle or a disconnecter. **DO NOT** connect it directly to a factory power source.
- Before performing any replacement procedure, turn OFF the Controller and related equipment, and then disconnect the power plug from the power source. Performing any replacement procedure with the power ON is extremely hazardous and may result in electric shock and/or malfunction of the robot system.
- Be sure to connect the cables properly. Do not allow unnecessary strain on the cables. (Do not put heavy objects on the cables. Do not bend or pull the cables forcibly.) The unnecessary strain on the cables may result in damage to the cables, disconnection, and/or contact failure.
- Grounding the manipulator is done by connecting with the controller. Ensure that the controller is grounded and the cables are correctly connected. If the ground wire is improperly connected to ground, it may result in the fire or electric shock.

#### CAUTION

- When connecting the Manipulator to the Controller, make sure that the serial numbers on each equipment match. Improper connection between the Manipulator and Controller may not only cause improper function of the robot system but also serious safety problems. The connection method varies with the Controller used. For details on the specifications, refer to the Controller manual.
- Connecting cables to the Manipulator shall be performed by personnel who has taken robot system training held by us and suppliers. This should also be performed by qualified personnel with knowledge · skills in electricity. Cable connection performed by personnels without such knowledge · skill may result in injuries and malfunction.

#### 4.3.6.1 Method to Connect the Manipulator and M/C Cable

1. Set the M/C cable as shown below.

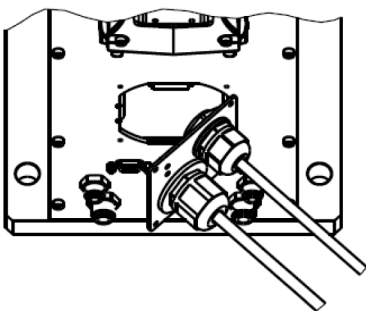

#### KEY POINTS

Be careful with the direction of the plate.

2. Connect the following connectors in the order shown below.

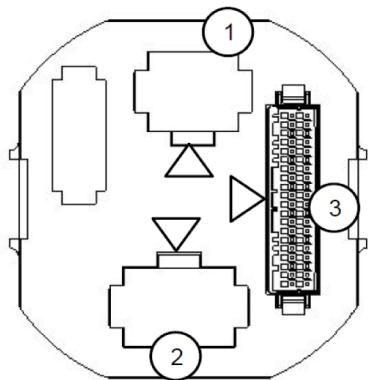

3. Install the plate.

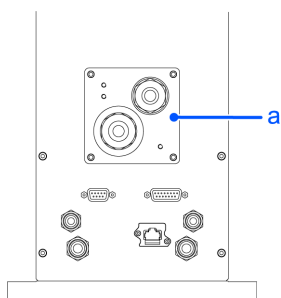

Symbol	Description
a	Plate

- Cross screw:  $4 \times M3 \times 6$
- Tightening torque:  $0.6 \pm 0.1 \text{ N}\cdot\text{m}$

### KEY POINTS

Be careful not to tighten the screws with the cables caught on the plate.

#### 4.3.6.2 Connecting M/C Cables and Controller

Connect the power connector and the signal connector of the M/C cable with each Controller.

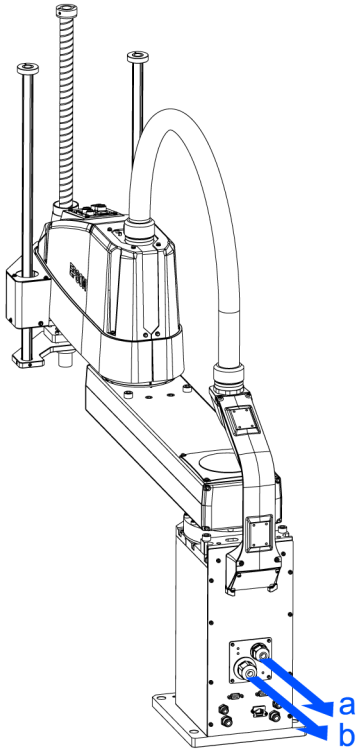

Symbol	Description
a	Signal Connector
b	Power Connector

There are two types of M/C cable: For fixing and movable. Movable cables have a line as shown in the figure below



### 4.3.7 Installed wire for customer use

**⚠ CAUTION**

- Only authorized or certified personnel should perform wiring. Wiring by unauthorized or uncertified staff may result in bodily injury and/or malfunction of the robot system.

User electrical wires and pneumatic tubes are contained in the cable unit.

#### 4.3.7.1 Electrical Wires

For the user connector of a Manipulator, connect the following connectors and cables.

**Specification of cables inside a Manipulator**

	Rated Voltage	Allowable Current	Wires	Nominal Sectional Area	Note
D-sub 15 pin	AC/DC 30V	1.0A	15	0.211 mm <sup>2</sup>	Twist pair/no shielding
D-sub 9 pin			9		
RJ45	-	-	-	-	Equivalent to CAT5e

Each connector is wired with pins that have the same number between the connectors on the base side of the Manipulator and the connectors on Arm #2's side.

**⚠ WARNING**

Do not apply the current more than 1A to the manipulator.

**Connectors to connect to the Manipulator (Recommended)**

		Manufacturer	Model type	Standard	Note
D-sub 15 pin	Connector	JST	DA-15PF-N	Solder type	Two included
	Clamp Hood	HRS	HDA-CTH(4-40)(10)	Connectors setscrew: #4-40 UNC	Two included
D-sub 9 pin	Connector	JST	DE-9PF-N	Solder type	Two included
	Clamp Hood	HRS	HDE-CTH(4-40)(10)	Connectors setscrew: #4-40 UNC	Two included
RJ45	Connector	CommScope	6-569550-3	-	-

**4.3.7.2 Pneumatic Tubes**

**Specification of Pneumatic tube within the Manipulator**

Max. Usable Pneumatic Pressure	The number of bolts	Outer Diameter×Inner Diameter
0.59Mpa (6 kgf/cm <sup>2</sup> : 86 psi)	2	ø6 mm× ø4 mm
	2	ø8 mm× ø5 mm

Fittings for ø6 mm and ø8 mm (outer diameter) pneumatic tubes are supplied on both ends of the pneumatic tubes.

**✍ KEY POINTS**

All fittings for ø6 mm, ø8 mm pneumatic tubes of LS50-C series are white. Be sure to check the numbers near the fittings and connect them properly.

**Pneumatic tubes to connect to the Manipulator (Recommended)**

Outer Diameter	Manufacturer	Model type	Note
ø6 mm	SMC	TU0604 *	Equivalent products from other companies can be used
ø8 mm	SMC	TU0805 *	Equivalent products from other companies can be used

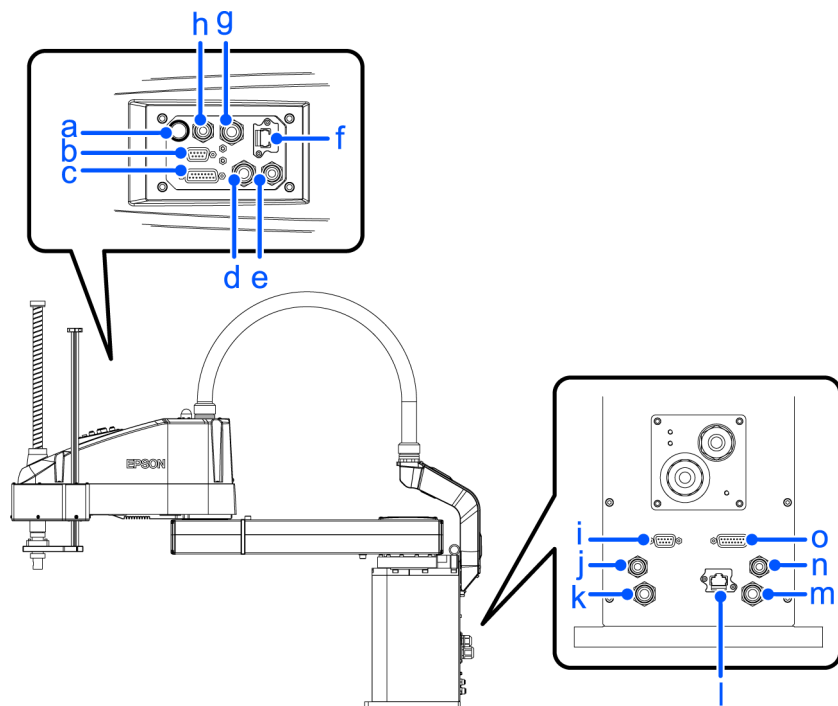

Symbol	Description
a	Brake release switch
b	User connector (9-pin D-sub connector)
c	User connector (15-pin D-sub connector)
d	Fitting (No.2) for ø8 mm pneumatic tube
e	Fitting (No.1) for ø6 mm pneumatic tube
f	Ethernet connector
g	Fitting (No.3) for ø8 mm pneumatic tube
h	Fitting (No.4) for ø6 mm pneumatic tube
i	User connector (9-pin D-sub connector)
j	Fitting (No.1) for ø6 mm pneumatic tube
k	Fitting (No.2) for ø8 mm pneumatic tube
l	Ethernet connector
m	Fittings for ø8 mm pneumatic tube (No. 3)
n	Fittings for ø6 mm pneumatic tube (No. 4)
o	User connector (15-pin D-sub connector)

### 4.3.8 Relocation and Storage

#### 4.3.8.1 Precautions for Relocation and Storage

Observe the following when relocating, storing, and transporting the Manipulators.

Transportation and installation of the Manipulator and robotic equipment shall be performed by personnel who has taken robot system training held by us and suppliers and should conform to all national and local codes.

**⚠ WARNING**

- Only authorized personnel should perform sling work and operate a crane and a forklift. When these operations are performed by unauthorized personnel, it is extremely hazardous and may result in serious bodily injury and/or severe equipment damage to the robot system.
- Stabilize the Manipulator with your hands when hoisting it. If you lose balance, the Manipulator may fall which could result in serious bodily injury and/or severe equipment damage.

**⚠ CAUTION**

- Before relocating the Manipulator, fold the arm and secure it tightly with a wire tie to prevent hands or fingers from being caught in the Manipulator.
- When removing the anchor bolts, support the Manipulator to prevent falling. Removing the anchor bolts without support may result in the Manipulator to fall, and then get hands, fingers, or feet caught.
- To carry the Manipulator, have two or more people to work on it and secure the Manipulator to the delivery equipment. Also, do not hold the shaded area in the figure. Doing so is extremely dangerous and can result in getting your hands and fingers caught.

When holding the shaded area (bottom of the base) by hand, be extremely careful not to get your hands or fingers caught.

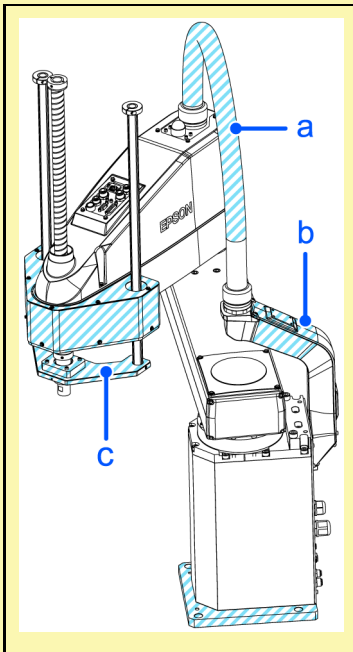
	Symbol	Description
	a	Resin Duct
	b	Metal Duct
	c	Support Plate
<ul style="list-style-type: none"> <li>• LS50-CA02S: approx. 60 kg: 132.3 lbs. (pound)</li> <li>• LS50-CA04S: approx. 61 kg: 134.5 lbs. (pound)</li> </ul> <p>(Figure: LS50-CA04S)</p>		

- Do not hold the metal duct, resin duct, or support duct when transporting the Manipulator. The duct part or the shaft may be damaged.

**✍ KEY POINTS**

When transporting the Manipulator for a long distance, secure it to the delivery equipment directly so that the Manipulator never falls over. If necessary, pack the Manipulator in the same style as it was delivered.

When the Manipulator is used for a robot system again after long-term storage, perform a test run to verify that it works properly, and then operate it thoroughly.

Transport and store the Manipulator in the range of Temperature: -20 to +60 °C, Humidity: 10 to 90% (no condensation).

When condensation occurs on the Manipulator during transport or storage, turn ON the power only after the condensation dries.

Do not shock or shake the Manipulator during transport.

### 4.3.8.2 Relocation

**⚠ CAUTION**

Install or relocate the Manipulator with two or more people. The Manipulator weights are as follows. Be careful not to get hands or feet caught and/or have equipment damaged by the Manipulator falling.

- LS50-CA02S: approx. 60 kg: 132.3 lbs. (pound)
- LS50-CA04S: approx. 61 kg: 134.5 lbs. (pound)

1. Turn OFF the power on all devices and unplug the cables.

**✎ KEY POINTS**

Remove the mechanical stops if using them to limit the motion range of Joints #1 and #2. For details on the motion range, refer to the following.

[Motion Range Setting by Mechanical Stops](#)

2. Cover the arm with a sheet so that the arm will not be damaged.  
 Insert the bolt to the screw hole on the arm and tie the bolt with the metal duct using a string. When fixing the arm using the shaft, fix it with adequate strength so as not to deform the spline. For details on the strength of the ball screw spline, refer to

#### Strength of the Ball Screw Spline

#### Example of Securing the Arm

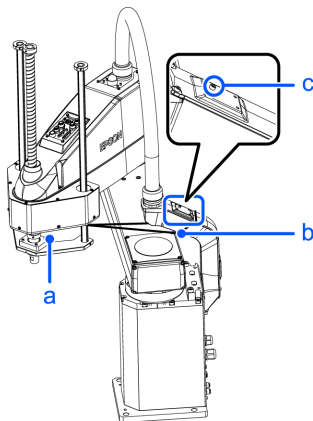

Symbol	Description
a	Eye bolts

Symbol	Description
b	Wire tie

3. Hold the bottom of Arm #1 by hand to unscrew the anchor bolts. Then, remove the Manipulator from the base table.

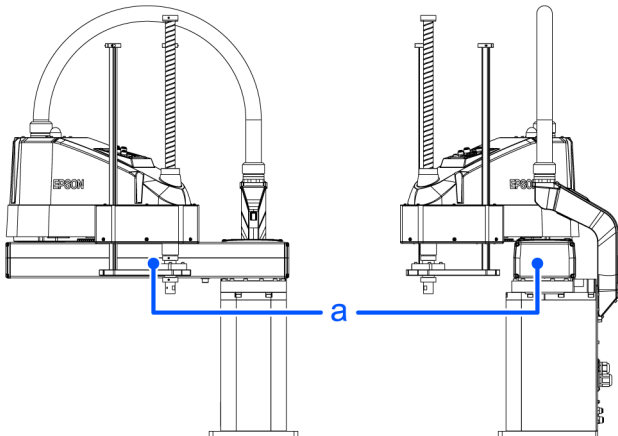

(Figure: LS50-CA04S)

Symbol	Description
a	Center of gravity

## 4.4 Setting of End Effectors

### 4.4.1 Attaching and End Effector

Users are responsible for making their own end effector(s). Be careful of the following points when attaching an end effector. For details on attaching a hand, refer to the following manual:

"Hand Function Manual"

#### **⚠ CAUTION**

- If you use an end effector equipped with a gripper or chuck, connect wires and/or pneumatic tubes properly so that the gripper does not release the workpiece when the power to the robot system is turned OFF. Improper connection of the wires and/or pneumatic tubes may damage the robot system and/or work piece as the work piece is released when the Emergency Stop switch is pressed.
- I/O outputs are configured at the factory so that they are automatically shut off (0) by power disconnection, the Emergency Stop switch, or the safety features of the robot system. However, the I/O set in the hand function does not turn off (0) when the Reset command is executed or in emergency stop.

#### **Shaft**

- Attach an end effector to the lower end of the shaft. For the shaft dimensions, and the overall dimensions of the Manipulator, refer to the following. **Specification**
- Do not move the upper limit mechanical stop on the lower side of the shaft. Otherwise, when "Jump motion" is performed, the upper limit mechanical stop may hit the Manipulator, and the robot system may not function properly.
- Use a split muff coupling with an M4 bolt or larger to attach the end effector to the shaft.

#### **Brake release switch**

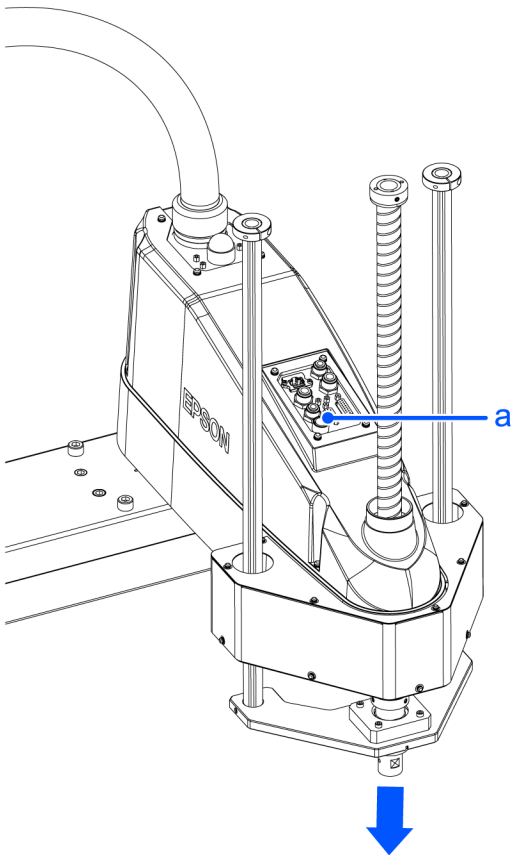

Shaft may be lowered by the weight of the end effector.

Symbol	Description
a	Brake release switch

- Joint #3 and #4 cannot be moved up/down by hand because the electromagnetic brake is applied to the joint while power to the robot system is turned OFF. This prevents the shaft from hitting peripheral equipment in the case that the shaft is lowered by the weight of the end effector when the power is disconnected during operation, or when the motor is turned OFF even though the power is turned ON.

To move Joint #3 up/down or rotate Joint #4 while attaching an end effector, turn ON the Controller and move the joint up/down or rotate the joint while pressing the brake release switch. This button switch is a momentary-type; the brake is released only while the button switch is being pressed

- Be careful of the shaft falling and rotating while the brake release switch is being pressed because the shaft may be lowered by the weight of the hand.

**Layouts**

- When you operate the manipulator with an end effector, the end effector may interfere with the Manipulator because of the outer diameter of the end effector, the size of the workpiece, or the position of the arms. When designing your system layout, pay attention to the interference area of the end effector.

**4.4.2 Attaching Cameras and Valves**

Arm #2 has threaded holes as shown in the figure below. Use M3 threaded holes on the top when attaching Ethernet cable to the arm. When attaching cameras and valves, attach it with a bracket to the mounting hole of the bottom of the plate or bottom of Arm #2 in the figure below.

(Unit : mm)

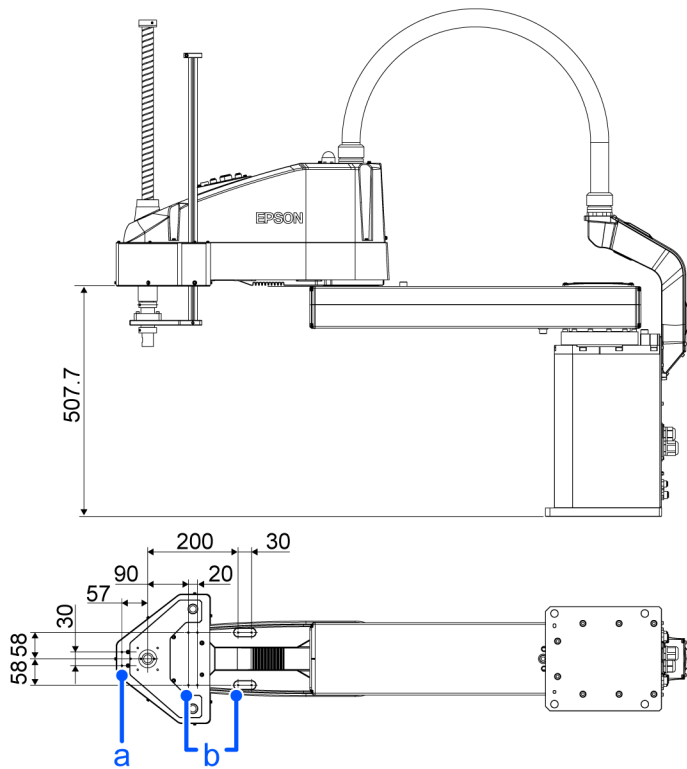

Symbol	Description
a	2×M4 Depth 10 *User tap
b	4×M4 Depth 10 *User tap

\*: From base installation surface

### 4.4.3 Weight and Inertia Settings

To ensure optimum Manipulator performance, it is important to make sure that the load (weight of the end effector and workpiece) and moment of inertia of the load are within the maximum rating for the Manipulator, and that Joint #4 does not become eccentric. If the load or moment of inertia exceeds the rating or if the load becomes eccentric, follow the steps below to set parameters.

- **Weight Setting**
- **Inertia Setting**

Setting parameters makes the PTP motion of the Manipulator optimal, reduces vibration to shorten the operating time, and improves the capacity for larger loads. In addition, it reduces persistent vibration produced when the moment of inertia of the end effector and work piece is larger than the default setting.

It can also be set from “Weight, Inertia, and Eccentricity/Offset Measurement”. For details, refer to the following manual.

“Epson RC+ User’s Guide - Weight, Inertia, and Eccentricity/Offset Measurement Utility”

### 4.4.3.1 Weight Setting

#### CAUTION

The total weight of the end effector and the workpiece must not exceed 50 kg. The LS50-C series are not designed to work with loads exceeding 50 kg. Always set the value according to the load. Setting a value that is smaller than the actual load may cause errors, shock and insufficient function of the Manipulator. Also, the life cycle of parts will shorten and belt tooth jumping will occur which will lead to position shift.

The acceptable weight capacity (end effector and workpiece) in LS50-C series

- Maximum: 50 kg

If the load weight exceeds the rated weight, change the setting for the hand weight parameter in the Weight command. After the setting is changed, the maximum acceleration/deceleration speed of the robot system at PTP motion corresponding to the “Weight Parameter” is set automatically.

### 4.4.3.2 Load on the Shaft

The load (weight of the end effector and work piece) on the shaft can be set by Weight parameter.

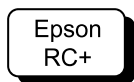

Enter a value into the [Weight:] text box on the [Weight] panel ([Tools]-[Robot Manager]). (You may also execute the Weight command from the [Command Window].)

### 4.4.3.3 Load on the Arm

When you attach a camera, valve or other devices to the arm, calculate the weight as the equivalent of the shaft. Then, add this to the weight of the load attached to the shaft, and enter the total weight to the Weight parameter.

#### Equivalent Weight Formula

When you attach a camera, valve or other devices to the arm, calculate the weight as the equivalent of the shaft. Then, add this to the weight of the load attached to the shaft, and enter the total weight to the Weight parameter.

If external wiring units (besides cables) are connected near the user connector on Arm #2’s side, add 0.16 kg to the shaft’s equivalent weight reduced value.

#### Equivalent Weight Formula

$$W_M = M \times (L_M + L_1)^2 / (L_1 + L_2)^2$$

$W_M$ : equivalent weight

$M$ : weight of the load of the Arm

$L_1$ : length of Arm #1

$L_2$ : length of Arm #2

$L_M$ : distance from rotation center of Joint #2 to center of gravity of the camera etc.

#### Example:

Calculates [Weight] parameter when a “1 kg” camera is attached to the end of the LS50-C arm (500 mm away from the rotation center of Joint #2) with a load weight of “2 kg”.

$$W = 2$$

$$M = 1$$

$L_1=550$

$L_2=450$

$L_M=500$

$W_M=1 \times (500+550)^2 / (450+550)^2 = 1.22$  (Round up to two decimal)

$W+W_M=2+1.22=3.22$

Enter “3.22” for the Weight Parameter.

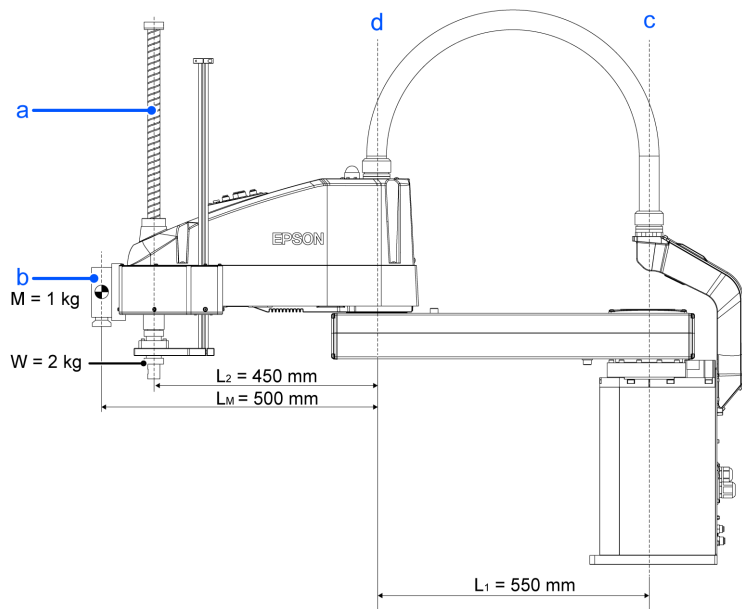

Symbol	Description
a	Shaft
b	Weight of the entire camera
c	Joint #1
d	Joint #2

#### 4.4.3.4 Automatic speed setting by Weight

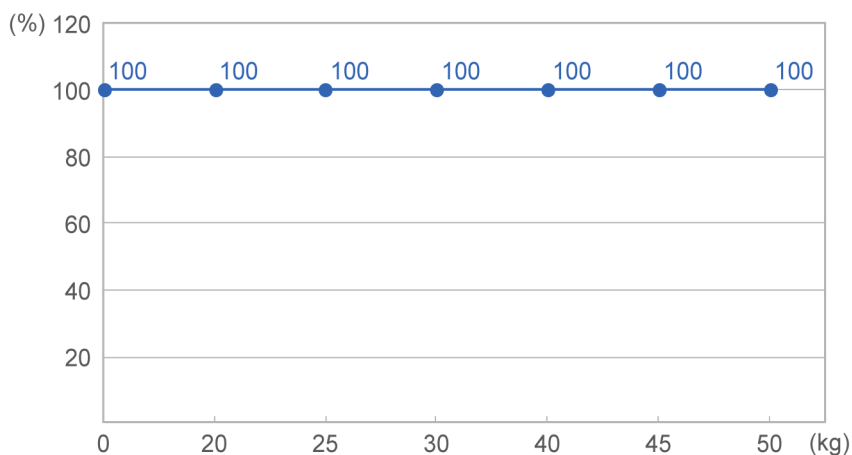

\* The percentage in the graph is based on the acceleration/ deceleration at rated weight (30 kg) as 100%.

End effector weight (kg)	Automatic speed setting by Weight (%)
0	100
20	100
25	100
30	100
40	100
45	100
50	100

#### 4.4.3.5 Automatic acceleration/deceleration setting by Weight

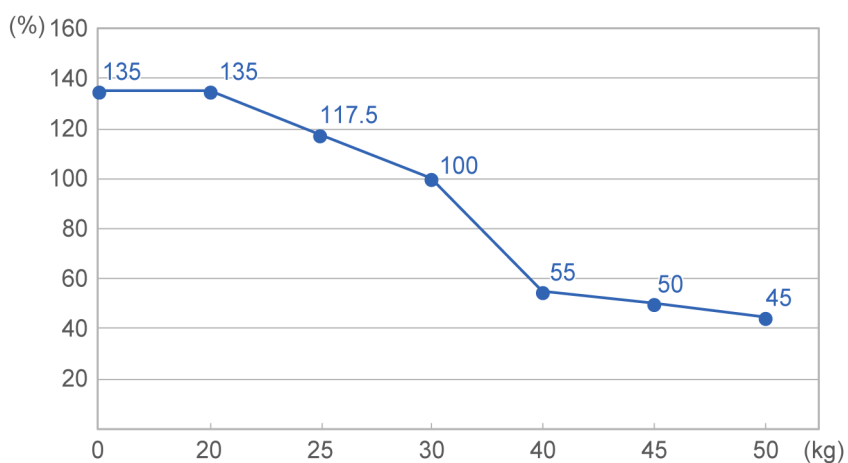

\* The percentage in the graph is based on the acceleration/ deceleration at rated weight (30 kg) as 100%.

End effector weight (kg)	Automatic acceleration/deceleration setting by Weight
0	135
20	135
25	117.5
30	100
40	55
45	50
50	45

#### 4.4.3.6 Inertia Setting

### 4.4.3.6.1 Moment of Inertia and the Inertia Setting

The moment of inertia is defined as “the ratio of the torque applied to a rigid body and its resistance to motion”. This value is typically referred to as “the moment of inertia”, “inertia”, or “GD2”. When the Manipulator operates with additional objects (such as an end effector) attached to the shaft, the moment of inertia of load must be considered.

**⚠ CAUTION**

The moment of inertia of the load (weight of the end effector and workpiece) must be 2.45 kg·m<sup>2</sup> or less. The LS50-C series are not designed to work with a moment of inertia exceeding 2.45 kg·m<sup>2</sup>. Always set the value according to the moment of inertia. Setting a value that is smaller than the actual moment of inertia may cause errors, shock and insufficient function of the Manipulator. Also, the life cycle of parts may be shortened and positional gap due to belt tooth bumping may occur.

The acceptable moment of inertia of load for a LS50-C series

- Rated weight: 1.00 kg·m<sup>2</sup>
- Maximum: 2.45 kg·m<sup>2</sup>

If the moment of inertia of the load exceeds the rated weight, change the setting of the moment of inertia parameter of the Inertia command. After the setting is changed, the maximum acceleration/deceleration speed of Joint #4 at PTP motion corresponding to the “moment of inertia” value is set automatically.

### 4.4.3.6.2 Moment of inertia of load on the shaft

The moment of inertia of load (weight of the end effector and workpiece) on the shaft can be set by the “moment of inertia” parameter of the Inertia command.

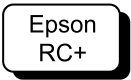

Enter a value into the [Moment of inertia] text box on the [Weight] panel ([Tools]-[Robot Manager]). (You may also execute the Inertia command from the [Command Window].)

### 4.4.3.6.3 Automatic acceleration/deceleration setting of Joint #4 by Inertia (moment of inertia)

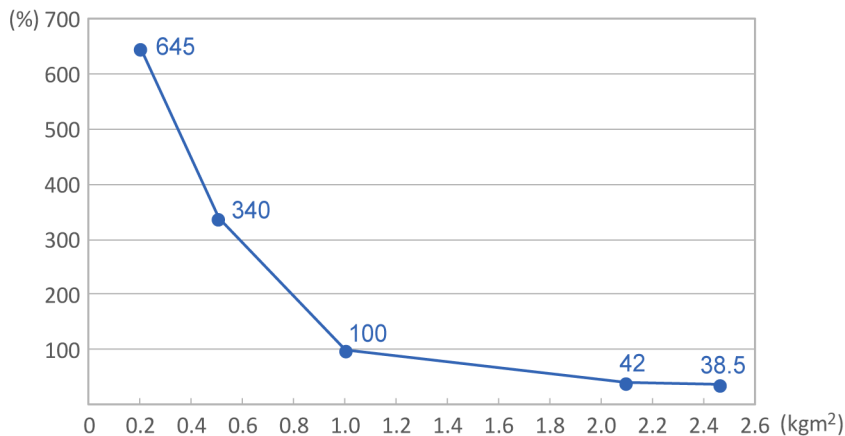

Moment of inertia setting parameter (kg·m <sup>2</sup> )	Automatic acceleration/deceleration (%) setting of Joint #4 by Inertia (moment of inertia)
0.2	645
0.5	340
1	100
2.1	42
2.45	38.5

#### 4.4.3.6.4 Eccentric Quantity and the Inertia Setting

#### ⚠ CAUTION

The eccentric quantity of the end effector and the workpiece must not exceed 200 mm. The LS50-C series are not designed to work with eccentric quantity exceeding 200 mm. Always set the Weight parameters according to the load. Setting a value that is smaller than the actual load may cause errors, excessive shock and insufficient function of the Manipulator. Also, the life cycle of parts may be shortened and positional gap due to belt tooth bumping may occur.

The acceptable eccentric quantity of load in LS50-C series is 0 mm at the default rating and 200 mm at the maximum. If the moment of inertia of the load exceeds the default rating, change the setting of eccentric quantity parameter of Inertia command. After the setting is changed, the maximum acceleration/deceleration speed of the Manipulator at PTP motion corresponding to the “eccentric quantity” is set automatically.

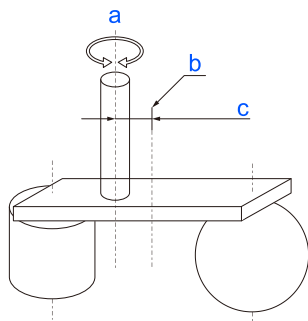

Symbol	Description
a	Rotation center
b	Position of load's center of gravity
c	Eccentric quantity

#### 4.4.3.6.5 Eccentric quantity of load on the shaft

The eccentric quantity of load (weight of the end effector and workpiece) on the shaft can be set by “eccentric quantity” parameter of Inertia command.

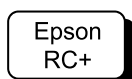

Enter a value into the [Eccentricity:] text box on the [Inertia] panel ([Tools]-[Robot Manager]). (You may also execute the Inertia command from the [Command Window].)

**4.4.3.6.6 Automatic acceleration/deceleration setting by Inertia (eccentric quantity)**

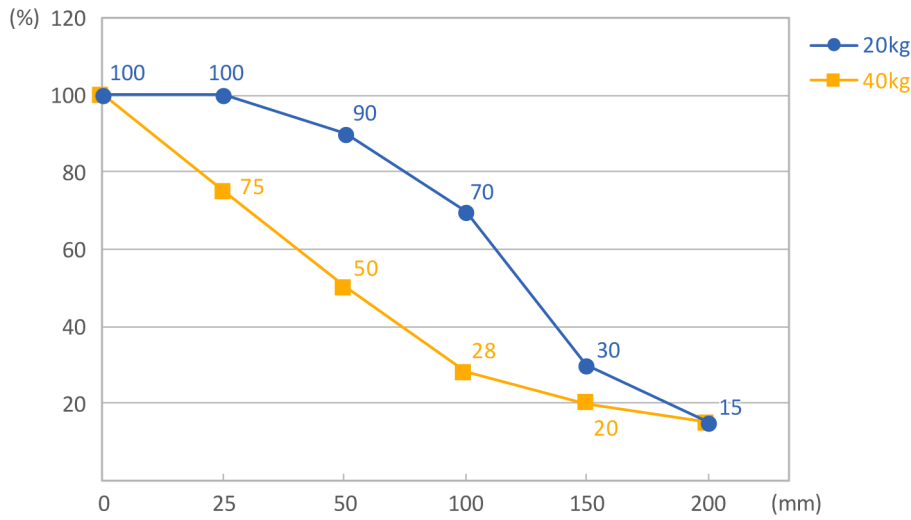

Eccentric quantity parameter (mm)	Automatic acceleration/deceleration setting by Inertia (eccentric quantity) (%)	
	20 kg	40 kg
0	100	100
25	100	70
50	90	50
100	70	28
150	30	20
200	15	15

**4.4.3.6.7 Calculating the Moment of Inertia**

Refer to the following examples of formulas to calculate the moment of inertia of load (end effector with workpiece). The moment of inertia of the entire load is calculated by the sum of each part (A), (B), and (C).

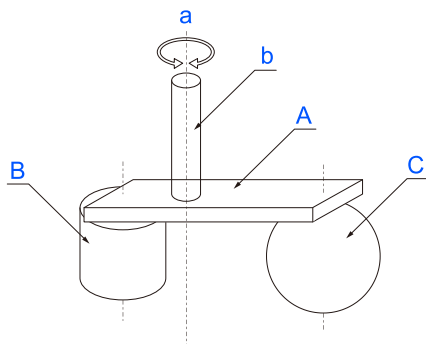

$$\text{Whole moment of inertia} = \text{Moment of inertia of end effector (A)} + \text{Moment of inertia of work piece (B)} + \text{Moment of inertia of work piece (C)}$$

Symbol	Description
a	Rotation center
b	Shaft
A	End effector
B	Workpiece
C	Workpiece

The methods for calculating the moment of inertia for (A), (B), and (C) are shown below. Calculate the total moment of inertia using the basic formulas.

**(A) Moment of inertia of a rectangular parallelepiped**

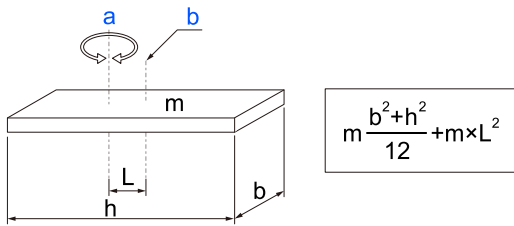

Symbol	Description
a	Rotation center
c	Rectangular parallelepiped's center of gravity

**(B) Moment of inertia of a cylinder**

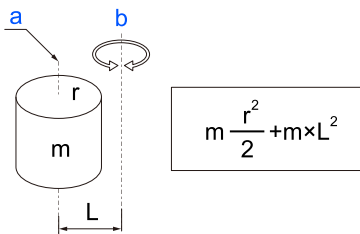

Symbol	Description
a	Cylinder's center of gravity
b	Rotation center

**(C) Moment of inertia of a sphere**

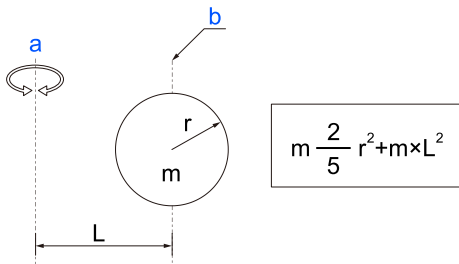

Symbol	Description
a	Rotation center

Symbol	Description
b	Sphere's center of gravity

### 4.4.4 Precautions for Auto Acceleration/Deceleration of Joint #3

When you move the Manipulator in horizontal PTP motion with Joint #3 (Z) at a high position, the motion time will be faster.

When Joint #3 gets below a certain point, then auto acceleration/deceleration is used to reduce acceleration/deceleration. (Refer to the figures below) The higher the position of the shaft is, the faster the motion acceleration/deceleration is. However, it takes more time to move Joint #3 up and down. Adjust the position of Joint #3 for the Manipulator motion after considering the relation between the current position and the destination position.

The upper limit of Joint #3 during horizontal motion using Jump command can be set by the LimZ command.

#### 4.4.4.1 Automatic acceleration/deceleration vs. Joint #3 position

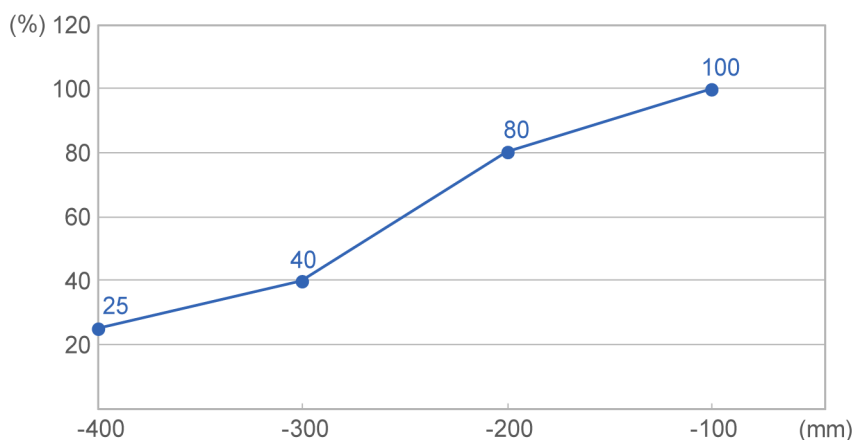

#### KEY POINTS

When moving the Manipulator horizontally while the shaft is being lowered, it may cause over-shoot at the time of final positioning.

Shaft height (mm)	Acceleration/Deceleration (%)
-100	100
-200	80
-300	40
-400	25

### 4.5 Motion Range

#### CAUTION

When setting up the motion range for safety, both the pulse range and mechanical stops must always be set at the same time.

The motion range is preset at the factory as explained in the following section.

### Standard Motion Range

This is the maximum motion range of the Manipulator.

There are three methods for setting the motion range described as follows:

1. Setting by pulse range (for all joints)
2. Setting by mechanical stops (for Joints #1 to #3)
3. Setting the Cartesian (rectangular) range in the X, Y coordinate system of the Manipulator (for Joints #1 and #2)

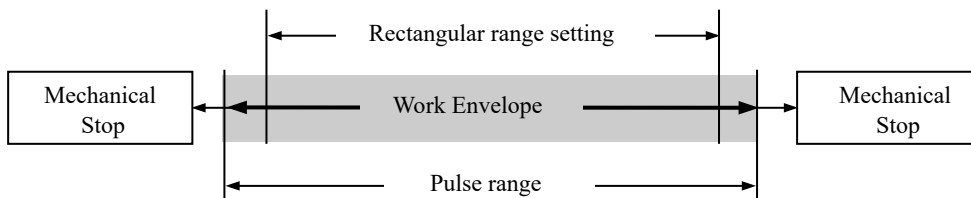

When the motion range is changed due to layout efficiency or safety, follow the descriptions below.

- [Motion Range Setting by Pulse Range](#)
- [Motion Range Setting by Mechanical Stops](#)
- [Setting the Cartesian \(Rectangular\) Range in the XY Coordinate System of the](#)

## 4.5.1 Motion Range Setting by Pulse Range

Pulses are the basic unit of Manipulator motion. The motion range of the Manipulator is controlled by the pulse range between the pulse lower limit and upper limit of each joint. Pulse values are read from the encoder output of the servo motor.

For the maximum pulse range, refer to the following sections. The pulse range must be set inside of the mechanical stop range.

- [Max. Pulse Range of Joint #1](#)
- [Max. Pulse Range of Joint #2](#)
- [Max. Pulse Range of Joint #3](#)
- [Max. Pulse Range of Joint #4](#)

### KEY POINTS

Once the Manipulator receives an operating command, it checks whether the target position specified by the command is within the pulse range before operating. If the target position is out of the set pulse range, an error occurs and the Manipulator does not move.

Epson  
RC+

The pulse range can be set on the [Range] panel shown by selecting [Tools]-[Robot Manager]. (You may also execute the Range command from the [Command Window].)

### 4.5.1.1 Max. Pulse Range of Joint #1

The 0 (zero) pulse position of Joint #1 is the position where Arm #1 faces toward the positive (+) direction on the X-coordinate axis. With the 0 pulse as a starting point, the counterclockwise pulse value is defined as the positive (+) and the clockwise pulse value is defined as the negative (-).

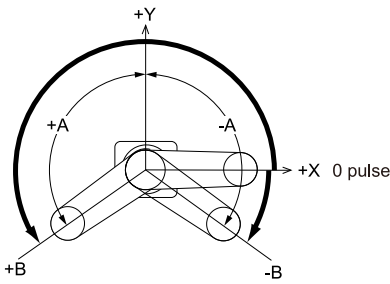

A: Max. Motion Range	B: Max. Pulse Range
±132°	- 231288 to 1222520 pulse

### 4.5.1.2 Max. Pulse Range of Joint #2

The 0 (zero) pulse position of Joint #2 is the position where Arm #2 is in-line with Arm #1. (Same for all direction of Arm #1)  
 With the 0 pulse as a starting point, the counterclockwise pulse value is defined as the positive (+) and the clockwise pulse value is defined as the negative (-).

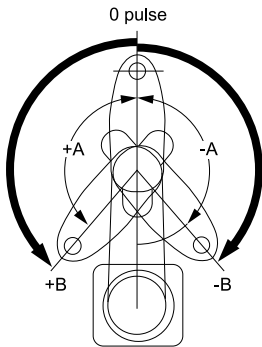

A: Max. Motion Range	B: Max. Pulse Range
±135 °	±491520 pulse

### 4.5.1.3 Max. Pulse Range of Joint #3

The 0 (zero) pulse position of Joint #3 is the position where the shaft is at its upper limit. The pulse value is always negative because Joint #3 always moves lower than the 0 pulse position.

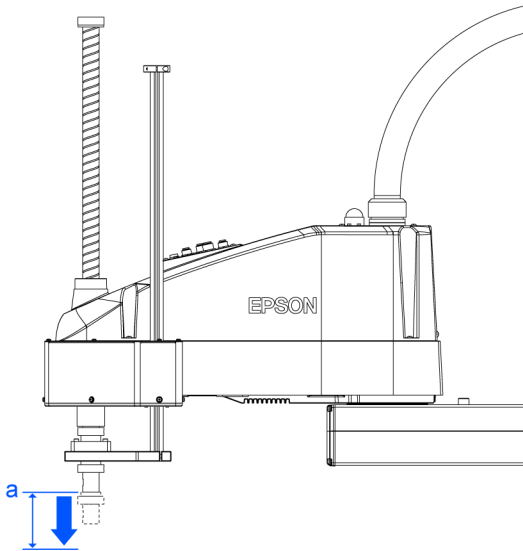

Symbol	Description
a	Upper limit: 0 pulse

Model number	Joint #3 stroke	Lower Limit Pulse
LS50-CA04S	400 mm	-806597 pulse
LS50-CA02S	210 mm	-423464 pulse

### 4.5.1.4 Max. Pulse Range of Joint #4

The 0 (zero) pulse position of Joint #4 is the position where the flat near the end of the shaft faces toward the end of Arm #2. (Same for all directions of Arm #2) With the 0 pulse as a starting point, the counterclockwise pulse value is defined as the positive (+) and the clockwise pulse value is defined as the negative (-).

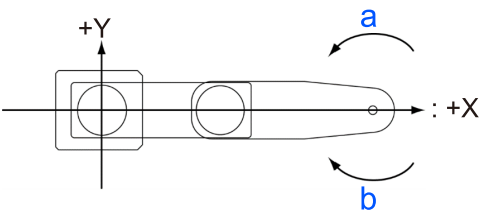

Symbol	Description
a	+ direction
b	- direction

Maximum Pulse Range: 0±737281 pulse

### 4.5.2 Motion Range Setting by Mechanical Stops

Mechanical stops physically limit the absolute area that the Manipulator can move.

Joints #1 have threaded holes in the positions corresponding to the angle for the mechanical stop settings. Set the motion range depending on the position of the mechanical stop (adjustable) Install the bolts in the holes corresponding to the angle that you want to set.

Joints #3 can be set to any length less than the maximum stroke.

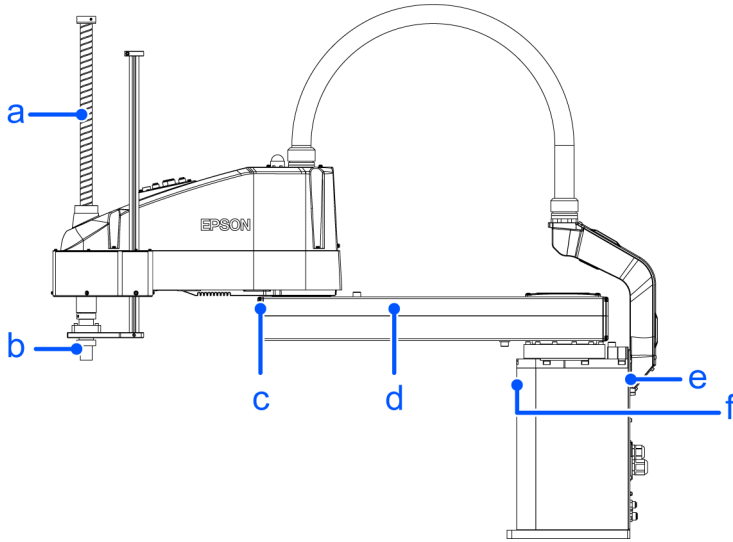

Symbol	Description
a	Mechanical stop of Joint #3 (Lower limit mechanical stop)
b	Mechanical stop of Joint #3 (Upper limit mechanical stop): Do not move the position.
c	Mechanical stop of Joint #2 (Fixed)
d	Mechanical stop of Joint #2 (Adjustable)
e	Mechanical stop of Joint #1 (Fixed)
f	Mechanical stop of Joint #1 (Adjustable)

### 4.5.2.1 Setting the Mechanical Stops of Joints #1

Joints #1 have threaded holes in the positions corresponding to the angle for the mechanical stop settings. Set the motion range depending on the position of the mechanical stop (adjustable) Install the bolts in the holes corresponding to the angle that you want to set.

Install the bolts for the mechanical stop to the following position.

#### Joint #1 Mechanical Stops

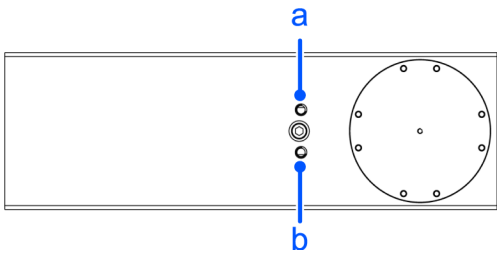

	a	b
Setting Angle (°)	122	-122
Pulse Value (pulse)	1167451	-176219

1. Turn off the Controller.
2. Install a hexagon socket head cap bolt into the hole corresponding to the setting angle, and tighten it.

Joint	Hexagon socket head cap bolt	The number of bolts	Recommended tightening torque	Strength
1	M10×60 full thread	1 bolt / side	13.0 N·m (132.7 kgf·cm)	ISO898-1 property class 10.9 or 12.9.

3. Turn on the Controller.

4. Set the pulse range corresponding to the new positions of the mechanical stops.

### KEY POINTS

Be sure to set the pulse range inside the positions of the mechanical stop range.

Example: Using LS50-CA0\*S to set Joint #1 from -110 to +110°

Epson  
RC+

Execute the following commands from the [Command Window].

```
>JRANGE 1, -110136, 1101368 ' Sets the pulse range of Joint #1
>RANGE ' Checks the set value using Range command
-110136,1101368, -491520, 491520,-806597,0, -737280, 737280
```

5. Move the arm by hand until it touches the mechanical stops, and make sure that the arm does not hit any peripheral equipment during operation.

6. Operate the joint changed at low speeds until it reaches the positions of the minimum and maximum pulse range. Make sure that the arm does not hit the mechanical stops.

(Check the position of the mechanical stop and the motion range you set.)

Example: Using LS50-CA0\*S to set Joint #1 from -110 to +110°

Epson  
RC+

Execute the following commands from the [Command Window].

```
>MOTOR ON ' Turns On the motor
>POWER LOW ' Enters low-power mode
>SPEED 5 ' Sets at low speed
>PULSE 1, -110136.0, 0.0 ' Moves to the min. pulse position of Joint #1
>PULSE 1101368,0,0,0 ' Moves to the max. pulse position of Joint #1
```

The Pulse command (Go Pulse command) moves all joints to the specified positions at the same time. Specify safe positions after considering motion of not only the joints whose pulse range have been changed, but also other joints.

If the arm is hitting the mechanical stops or if an error occurs after the arm hits the mechanical stops, either reset the pulse range to a narrower setting or extend the positions of the mechanical stops within the limit.

### 4.5.2.2 Setting the Mechanical Stops of Joints #3

1. Turn ON the Controller and turn OFF the motors using the Motor OFF command.
2. Push up the shaft while pressing the brake release switch.

#### KEY POINTS

Do not push the shaft up to its upper limit or it will be difficult for the arm top cover to be removed. Push the shaft up to a position where the Joint #3 mechanical stop can be changed.

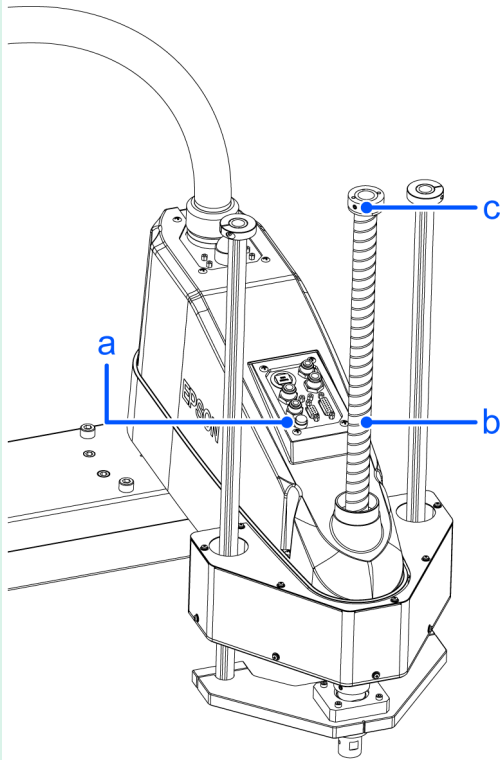

When you press the brake release switch, the shaft may lower or rotate due to the weight of the end effector. Be sure to hold the shaft by hand while pressing the button.

3. Turn off the Controller.
4. Loosen the lower limit mechanical stop screw (set screws: 2-M5×6).

#### KEY POINTS

A mechanical stop is mounted on both the top and bottom of Joint #3. However, only the position of the lower limit mechanical stop on the top can be changed. Do not remove the upper limit mechanical stop on the bottom because the calibration point of Joint #3 is specified using the stop.

5. The upper end of the shaft defines the maximum stroke. Move the lower limit mechanical stop down by the length you want to limit the stroke.  
For example, when the lower limit mechanical stop is set at “400 mm” stroke, the lower limit Z coordinate value is “-400”.

To change the value to “-100”, move the lower limit mechanical stop down “300 mm”. Use calipers to measure the distance when adjusting the mechanical stop.

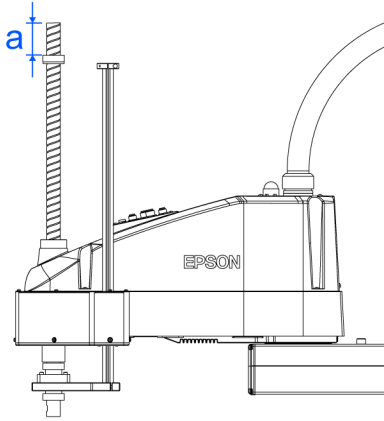

6. Firmly tighten the lower limit mechanical stop screw (set screws: 2-M5×6).  
Recommended tightening torque: 4.0 N m (40.8 kgf cm)
7. Turn on the Controller.
8. Move Joint #3 to its lower limit while pressing the brake release switch, and then check the lower limit position.  
Do not lower the mechanical stop too far. Otherwise, the joint may not reach a target position.
9. Calculate the lower limit pulse value of the pulse range using the formula shown below and set the value.  
The result of the calculation is always negative because the lower limit Z coordinate value is negative.  
Lower limit of pulse (pulse) = lower limit Z coordinate value (mm) / Joint #3 Resolution\*\* (mm/pulse)  
\*\* For the Joint #3 resolution, refer to the section Appendix A: Specifications.

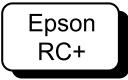

Execute the following commands from the [Command Window]. Enter the calculated value in X.

```
>JRANGE 3,X,0      '      Sets the pulse range of Joint #3
```

10. Using the Pulse command (Go Pulse command), move Joint #3 to the lower limit position of the pulse range at low speed.  
If the mechanical stop range is less than the pulse range, Joint #3 will hit the mechanical stop and an error will occur. When the error occurs, either change the pulse range to a lower setting or extend the position of the mechanical stop within the limit.

**KEY POINTS**

---

If it is difficult to check whether Joint #3 hits a mechanical stop, turn OFF the Controller and lift the arm top cover to check the condition causing the problem from the side.

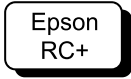

Execute the following commands from the [Command Window]. Enter the value calculated in Step (9) in X.

```
>MOTOR ON          '      Turns On the motor
>SPEED 5           '      Sets at low speed
>PULSE 0,0,X,0     '      Moves to the lower limit-pulse position of Joint #3
(In this example, all pulses except those for Joint #3 are "0". Substitute these
```

“0s” with the other pulse values specifying a position where there is no interference even when lowering Joint #3.)

### 4.5.3 Setting the Cartesian (Rectangular) Range in the XY Coordinate System of the

Manipulator (for Joints #1 and #2)

Use this method to set the upper and lower limits of the X and Y coordinates.

This setting is only enforced by software. Therefore, it does not change the physical range. The maximum physical range is based on the position of the mechanical stops.

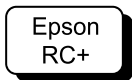

Set the XYLim setting on the [XYZ Limits] panel shown by selecting [Tools]-[Robot Manager]. (You may also execute the XYLim command from the [Command Window].)

### 4.5.4 Standard Motion Range

#### Motion Range

The following “motion range” diagrams show the standard (maximum) specification. When each Joint motor is under servo control, the center of Joint #3’s (shaft’s) lowest point moves in the areas shown in the figure.

#### Area limited by a mechanical stop

The area where the center of Joint #3’s lowest point can be moved when each joint motor is not under servo control.

#### Mechanical stop

The area that contains the farthest reach of the arms.

#### Maximum Range

The area that contains the farthest reach of the arms. If the maximum radius of the end effector is over 60 mm, add the “Area limited by mechanical stop” and “radius of the end effector” as the maximum area.

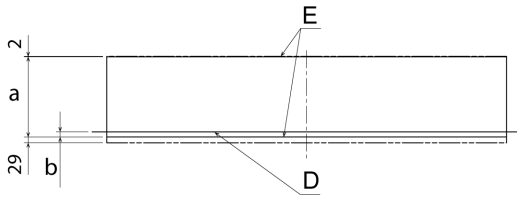
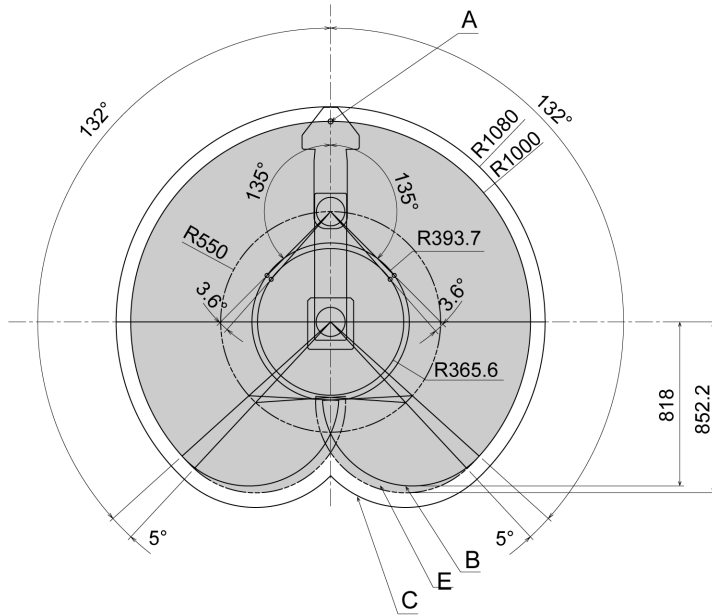

A	Center of Joint #3
B	Motion Range
C	Maximum Range
D	Base mounting face
E	Area limited by a mechanical stop

		LS50-CA02S	LS50-CA04S
a	(Joint #3 motion range)	210	400
b	(Distance from the base mounting face)	164.5	25.5

## 5. Daily Inspection

Accurate inspection work is necessary to prevent breakdowns and ensure safety. This section explains the inspection schedule and what should be inspected.

Perform inspections according to the predetermined schedule.

## 5.1 Daily Inspection of LS4-C and LS8-C Manipulator

Accurate inspection work is necessary to prevent breakdowns and ensure safety. This section explains the inspection schedule and what should be inspected.

Perform inspections according to the predetermined schedule.

### 5.1.1 Inspection

#### 5.1.1.1 Schedule for Inspection

Inspection items are divided into five stages (daily, 1-month, 3-month, 6-month, and 12-month), with additional items added at each stage. However, if the Manipulator is powered and operated for more than 250 hours in a month, add inspection items every 250, 750, 1500, and 3000 hours.

	Inspection Item					
	Daily Inspection	1-month Inspection	3-month Inspection	6-month Inspection	12-month Inspection	Overhaul (Parts Replacement)
1 months (250 hours)	Perform daily	✓				
2 months (500 hours)		✓				
3 months (750 hours)		✓	✓			
4 months (1,000 hours)		✓				
5 months (1,250 hours)		✓				
6 months (1,500 hours)		✓	✓	✓		
7 months (1,750 hours)		✓				
8 months (2,000 hours)		✓				
9 months (2,250 hours)		✓	✓			
10 months (2,500 hours)		✓				
11 months (2,750 hours)		✓				
12 months (3,000 hours)		✓	✓	✓	✓	
13 months (3,250 hours)		✓				
⋮	⋮	⋮	⋮	⋮	⋮	⋮

	Inspection Item					
	Daily Inspection	1-month Inspection	3-month Inspection	6-month Inspection	12-month Inspection	Overhaul (Parts Replacement)
(20,000 hours)						✓

### 5.1.1.2 Inspection point

#### Inspection item

Inspection item	Inspection Spot	Daily inspection	Monthly inspection	Quarterly inspection	Biannual inspection	Annual inspection
Check looseness or backlash of bolts/screws.	End effector mounting bolts	✓	✓	✓	✓	✓
	Manipulator mounting bolts	✓	✓	✓	✓	✓
Check looseness of connectors.	External connectors on Manipulator (on the connector plates etc.)	✓	✓	✓	✓	✓
Visually check for external defects. Clean up if necessary.	The entire Manipulator	✓	✓	✓	✓	✓
	External cables		✓	✓	✓	✓
Check for bends or improper location. Repair or place it properly if necessary.	Safeguard etc.	✓	✓	✓	✓	✓
Check the brake operation	Brake for arm #3 to #4	✓	✓	✓	✓	✓
Check whether unusual sound or vibration occurs.	Whole	✓	✓	✓	✓	✓

#### Inspection Method

Inspection Point	Inspection Method
Check looseness or backlash of bolts/screws.	Use a hexagonal wrench to check that the end effector mounting bolts and the Manipulator mounting bolts are not loose. When the bolts are loose, refer to the following and tighten them to the proper torque. <b>Tightening the hexagon socket head cap bolt</b>
Check looseness of connectors	Check that connectors are not loose. When the connectors are loose, reattach it so that it does not come off.
Visually check for external defects. Clean up if necessary.	Check the appearance of the Manipulator and clean up if necessary. Check the appearance of the cable, and if it is scratched, check that there is no cable disconnection.
Check for bends or improper location.	Check that the safeguard, etc. are located properly. If the location is improper, place it properly.

Inspection Point	Inspection Method
Check the brake operation	Check that the shaft does not fall when in MOTOR OFF. If the shaft falls when in MOTOR OFF and the brake is not released, contact the supplier. Also, if the brake is not released even after operating the brake release, contact the supplier.
Check whether unusual sound or vibration occurs.	Check that there is no unusual sound or vibration when operating. If there is something wrong, contact the supplier.

### 5.1.2 Overhaul (Parts Replacement)

Overhaul (replacement) shall be performed by properly trained service engineers.

For details, refer to the following manual.  
 "Safety Manual - Role and Training for Safety Managers"

For details on overhaul, refer to the following manual.

“Maintenance Manual”

### 5.1.3 Greasing

The ball screw spline and reduction gear units need greasing regularly. Only use the grease specified.

**⚠ CAUTION**



- Pay attention to the amount of greasing When greasing runs out, it can cause the slide part to get damaged which may result in not only the ball screw spline and reduction gear units to not function properly but also cost an incredible amount of money and time.
- Wear protective gear including a mask, protective goggles, and oil-resistant gloves during grease up. If grease gets into your eyes, mouth, or on your skin, follow the instructions below.
  - If grease gets into your eyes  
 Flush them thoroughly with clean water, and then see a doctor immediately.
  - If grease gets into your mouth  
 If swallowed, do not induce vomiting. See a doctor immediately. If grease gets into your mouth, wash your mouth with water thoroughly.
  - If grease gets on your skin  
 Wash the area thoroughly with soap and water.

	Greasing part	Greasing Interval	Grease	How to grease
Joint #1, Joint #2	Reduction gear units	Overhaul timing	-	Greasing shall be performed by personnel who has taken a proper training. For details, refer to the Manipulator’s maintenance manual.

	Greasing part	Greasing Interval	Grease	How to grease
Joint #3	Ball Screw Spline Unit	At 100 km of operation (50 km for first greasing)	AFB	Greasing the Ball Screw Spline Unit (mentioned below)

**Joint #3 ball screw spline unit**

The recommended greasing interval is at 100 km of operation. However, greasing interval can also be checked from the grease condition. Perform greasing if the grease is discolored or becomes dry.

Normal grease	Dicolored grease
	

Perform greasing at 50 km of operation for the first time of greasing.

**KEY POINTS**

In Epson RC+, the recommended greasing interval is referred in Epson RC+ [Maintenance].

**Greasing the Ball Screw Spline Unit**

	Name	Qty.	Note
Grease	For Ball Screw Spline Unit (AFB grease)	Proper quantity	
Tools	Wiping cloth	1	For wiping grease (Spline shaft)
	Cross-point screwdriver	1	

**KEY POINTS**

Cover the surrounding area such as the end effector and peripheral equipment in case the grease drips.

1. Turn ON the Controller.
2. Move the shaft to its lower limit in one of the following methods.
  - Move the shaft to its lower limit manually while pressing the brake release switch.
  - Move the shaft to its lower limit from Epson RC+ [Tools]-[Robot Manager]-[Jog & Teach].

**CAUTION**

- Be sure to keep enough space and prevent the end effector hitting any peripheral equipment.

- The brake release switch affects both Joints #3 and #4. When the brake release switch is pressed, the brakes for both Joints #3 and #4 are released simultaneously. Be careful of the shaft falling and rotating due to hand weight while the brake release switch is being pressed.

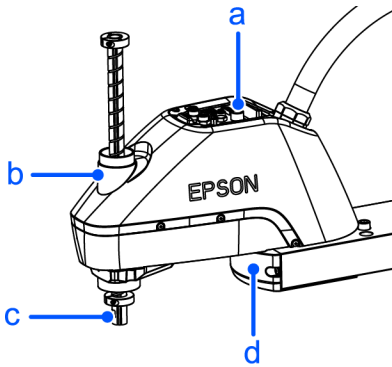

Symbol	Description
a	Joint #3 #4 Brake release switch
b	Arm #2
c	Shaft
d	Arm #1

3. Turn off the Controller.

4. Wipe off the old grease from the shaft, and then apply new grease to it.

The grease application area is from the end of the spline nut to the mechanical stop.

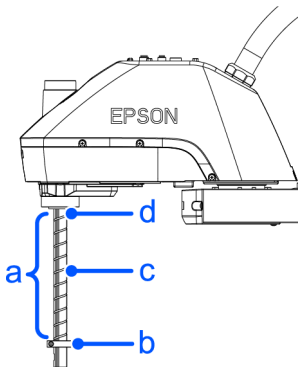

Symbol	Description
a	Grease application range
b	Mechanical stop
c	Shaft
d	End of the spline nut

5. Grease should be applied to the helical grooves of the of the ball screw and vertical grooves spline so that the grooves are filled evenly.

Grease application example:



6. Turn on the Controller.
7. Start the robot manager and move the shaft to the origin position.  
  
Be careful not to hit peripheral equipment.
8. After moving to the origin position, reciprocate the shaft. The reciprocating operation is a low power mode operation program that performs from the upper limit to the lower limit. Run for about 5 minutes to spread the grease over the shaft.
9. Turn off the Controller.
10. Wipe off any excess grease at the end of the spline nut and mechanical stop.

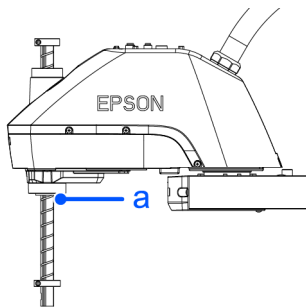

Symbol	Description
a	End of the spline nut

### 5.1.4 Tightening the hexagon socket head cap bolt

Hexagon socket head cap bolts (referred to as "bolts" below) are used in locations where mechanical strength is required. During assembly, these bolts are tightened at the tightening torques shown in the following table.

Unless otherwise specified, when retightening these bolts in the work procedures described in this manual, use a torque wrench or similar tool to obtain the tightening torques in the following table.

Bolt	Tightening Torque
M3	2.0 ± 0.1 N·m (21 ± 1 kgf·cm)
M4	4.0 ± 0.2 N·m (41 ± 2 kgf·cm)
M5	8.0 ± 0.4 N·m (82 ± 4 kgf·cm)
M6	13.0 ± 0.6 N·m (133 ± 6 kgf·cm)
M8	32.0 ± 1.6 N·m (326 ± 16 kgf·cm)

Bolt	Tightening Torque
M10	$58.0 \pm 2.9 \text{ N}\cdot\text{m}$ ( $590 \pm 30 \text{ kgf}\cdot\text{cm}$ )
M12	$100.0 \pm 5.0 \text{ N}\cdot\text{m}$ ( $1,020 \pm 51 \text{ kgf}\cdot\text{cm}$ )

For set screw, refer to the following table.

Set Screw	Tightening Torque
M4	$2.4 \pm 0.1 \text{ N}\cdot\text{m}$ ( $26 \pm 1 \text{ kgf}\cdot\text{cm}$ )
M5	$3.9 \pm 0.2 \text{ N}\cdot\text{m}$ ( $40 \pm 2 \text{ kgf}\cdot\text{cm}$ )
M6	$8.0 \pm 0.4 \text{ N}\cdot\text{m}$ ( $82 \pm 4 \text{ kgf}\cdot\text{cm}$ )

It is recommended that bolts arranged in a circular pattern be secured in place by tightening in criss-cross order as shown in the figure.

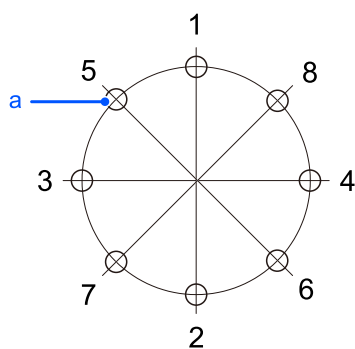

Symbol	Description
a	Threaded holes

When securing the bolts, do not tighten the bolts all at once, but tighten them in two or three separate rounds with an Allen wrench, and then use a torque wrench or similar tool to secure them at the tightening torques shown in the table above.

## 5.2 Daily Inspection of LS20-C Manipulator

Accurate inspection work is necessary to prevent breakdowns and ensure safety. This section explains the inspection schedule and what should be inspected.

Perform inspections according to the predetermined schedule.

### 5.2.1 Inspection

#### 5.2.1.1 Schedule for Inspection

Inspection items are divided into five stages (daily, 1-month, 3-month, 6-month, and 12-month), with additional items added at each stage. However, if the Manipulator is powered and operated for more than 250 hours in a month, add inspection items every 250, 750, 1500, and 3000 hours.

	Inspection Item					
	Daily Inspection	1-month Inspection	3-month Inspection	6-month Inspection	12-month Inspection	Overhaul (Parts Replacement)
1 months (250 hours)	Perform daily	✓				
2 months (500 hours)		✓				
3 months (750 hours)		✓	✓			
4 months (1,000 hours)		✓				
5 months (1,250 hours)		✓				
6 months (1,500 hours)		✓	✓	✓		
7 months (1,750 hours)		✓				
8 months (2,000 hours)		✓				
9 months (2,250 hours)		✓	✓			
10 months (2,500 hours)		✓				
11 months (2,750 hours)		✓				
12 months (3,000 hours)		✓	✓	✓	✓	
13 months (3,250 hours)		✓				
⋮	⋮	⋮	⋮	⋮	⋮	⋮

	Inspection Item					
	Daily Inspection	1-month Inspection	3-month Inspection	6-month Inspection	12-month Inspection	Overhaul (Parts Replacement)
(20,000 hours)						✓

### 5.2.1.2 Inspection point

#### Inspection item

Inspection item	Inspection Spot	Daily inspection	Monthly inspection	Quarterly inspection	Biannual inspection	Annual inspection
Check looseness or backlash of bolts/screws.	End effector mounting bolts	✓	✓	✓	✓	✓
	Manipulator mounting bolts	✓	✓	✓	✓	✓
Check looseness of connectors.	External connectors on Manipulator (on the connector plates etc.)	✓	✓	✓	✓	✓
Visually check for external defects. Clean up if necessary.	The entire Manipulator	✓	✓	✓	✓	✓
	External cables		✓	✓	✓	✓
Check for bends or improper location. Repair or place it properly if necessary.	Safeguard etc.	✓	✓	✓	✓	✓
Check the brake operation	Brake for arm #3 to #4	✓	✓	✓	✓	✓
Check whether unusual sound or vibration occurs.	Whole	✓	✓	✓	✓	✓

#### Inspection Method

Inspection Point	Inspection Method
Check looseness or backlash of bolts/screws.	Use a hexagonal wrench to check that the end effector mounting bolts and the Manipulator mounting bolts are not loose. When the bolts are loose, refer to the following and tighten them to the proper torque. <b>Tightening the hexagon socket head cap bolt</b>
Check looseness of connectors	Check that connectors are not loose. When the connectors are loose, reattach it so that it does not come off.
Visually check for external defects. Clean up if necessary.	Check the appearance of the Manipulator and clean up if necessary. Check the appearance of the cable, and if it is scratched, check that there is no cable disconnection.
Check for bends or improper location.	Check that the safeguard, etc. are located properly. If the location is improper, place it properly.

Inspection Point	Inspection Method
Check the brake operation	Check that the shaft does not fall when in MOTOR OFF. If the shaft falls when in MOTOR OFF and the brake is not released, contact the supplier. Also, if the brake is not released even after operating the brake release, contact the supplier.
Check whether unusual sound or vibration occurs.	Check that there is no unusual sound or vibration when operating. If there is something wrong, contact the supplier.

### 5.2.2 Overhaul (Parts Replacement)

Overhaul (replacement) shall be performed by properly trained service engineers.

For details, refer to the following manual.  
 "Safety Manual - Role and Training for Safety Managers"

For details on overhaul, refer to the following manual.

“Maintenance Manual”

### 5.2.3 Greasing

The ball screw spline and reduction gear units need greasing regularly. Only use the grease specified.

**⚠ CAUTION**



- Pay attention to the amount of greasing When greasing runs out, it can cause the slide part to get damaged which may result in not only the ball screw spline and reduction gear units to not function properly but also cost an incredible amount of money and time.
- Wear protective gear including a mask, protective goggles, and oil-resistant gloves during grease up. If grease gets into your eyes, mouth, or on your skin, follow the instructions below.
  - If grease gets into your eyes  
 Flush them thoroughly with clean water, and then see a doctor immediately.
  - If grease gets into your mouth  
 If swallowed, do not induce vomiting. See a doctor immediately. If grease gets into your mouth, wash your mouth with water thoroughly.
  - If grease gets on your skin  
 Wash the area thoroughly with soap and water.

	Greasing part	Greasing Interval	Grease	How to grease
Joint #1, Joint #2	Reduction gear units	Overhaul timing	-	Greasing shall be performed by personnel who has taken a proper training. For details, refer to the Manipulator’s maintenance manual.

	Greasing part	Greasing Interval	Grease	How to grease
Joint #3	Ball Screw Spline Unit	At 100 km of operation (50 km for first greasing)	AFB	Greasing the Ball Screw Spline Unit (mentioned below)

### Joint #3 ball screw spline unit

The recommended greasing interval is at 100 km of operation. However, greasing interval can also be checked from the grease condition. Perform greasing if the grease is discolored or becomes dry.

Normal grease	Dicolored grease
	

Perform greasing at 50 km of operation for the first time of greasing.

#### KEY POINTS

In Epson RC+, the recommended greasing interval is referred in Epson RC+ [Maintenance].

### Greasing the Ball Screw Spline Unit

	Name	Qty.	Note
Grease	For Ball Screw Spline Unit (AFB grease)	Proper quantity	
Tools	Wiping cloth	1	For wiping grease (Spline shaft)
	Cross-point screwdriver	1	

#### KEY POINTS

Cover the surrounding area such as the end effector and peripheral equipment in case the grease drips.

1. Turn ON the Controller.
2. Move the shaft to its lower limit in one of the following methods.
  - Move the shaft to its lower limit manually while pressing the brake release switch.
  - Move the shaft to its lower limit from Epson RC+ [Tools]-[Robot Manager]-[Jog & Teach].

#### CAUTION

- Be sure to keep enough space and prevent the end effector hitting any peripheral equipment.

- The brake release switch affects both Joints #3 and #4. When the brake release switch is pressed, the brakes for both Joints #3 and #4 are released simultaneously. Be careful of the shaft falling and rotating while the brake release switch is being pressed because the shaft may be lowered by the weight of the hand.

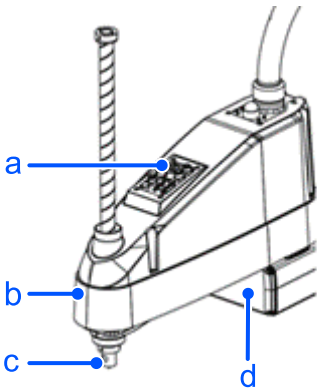

Symbol	Description
a	Joint #3 #4 Brake release switch
b	Arm #2
c	Shaft
d	Arm #1

3. Turn off the Controller.

4. Wipe off the old grease from the shaft, and then apply new grease to it.

The grease application area is from the end of the spline nut to the mechanical stop.

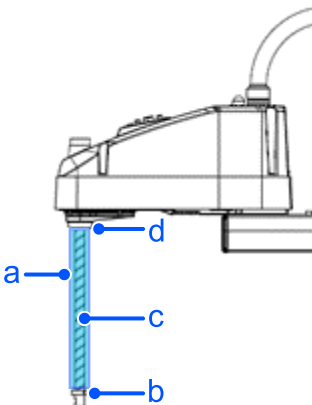

Symbol	Description
a	Grease application range
b	Mechanical stop
c	Shaft
d	End of the spline nut

5. Grease should be applied to the helical grooves of the of the ball screw and vertical grooves spline so that the grooves are filled evenly.

Grease application example:



- 6. Turn on the Controller.
- 7. Start the robot manager and move the shaft to the origin position.

Be careful not to hit peripheral equipment.

- 8. After moving to the origin position, reciprocate the shaft. The reciprocating operation is a low power mode operation program that performs from the upper limit to the lower limit. Run for about 5 minutes to spread the grease over the shaft.

- 9. Turn off the Controller.

- 10. Wipe off any excess grease at the end of the spline nut and mechanical stop.

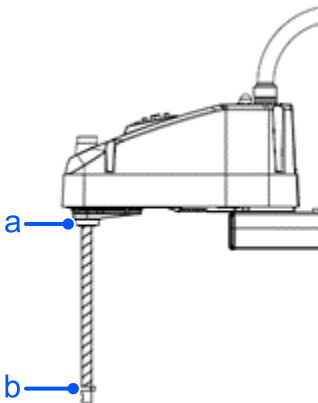

Symbol	Description
a	End of the spline nut
b	Mechanical stop

### 5.2.4 Tightening the hexagon socket head cap bolt

Hexagon socket head cap bolts (referred to as "bolts" below) are used in locations where mechanical strength is required. During assembly, these bolts are tightened at the tightening torques shown in the following table.

Unless otherwise specified, when retightening these bolts in the work procedures described in this manual, use a torque wrench or similar tool to obtain the tightening torques in the following table.

Bolt	Tightening Torque
M3	2.0 ± 0.1 N·m (21 ± 1 kgf·cm)
M4	4.0 ± 0.2 N·m (41 ± 2 kgf·cm)

Bolt	Tightening Torque
M5	8.0 ± 0.4 N·m (82 ± 4 kgf·cm)
M6	13.0 ± 0.6 N·m (133 ± 6 kgf·cm)
M8	32.0 ± 1.6 N·m (326 ± 16 kgf·cm)
M10	58.0 ± 2.9 N·m (590 ± 30 kgf·cm)
M12	100.0 ± 5.0 N·m (1,020 ± 51 kgf·cm)

For set screw, refer to the following table.

Set Screw	Tightening Torque
M4	2.4 ± 0.1 N·m (26 ± 1 kgf·cm)
M5	3.9 ± 0.2 N·m (40 ± 2 kgf·cm)
M6	8.0 ± 0.4 N·m (82 ± 4 kgf·cm)

It is recommended that bolts arranged in a circular pattern be secured in place by tightening in criss-cross order as shown in the figure.

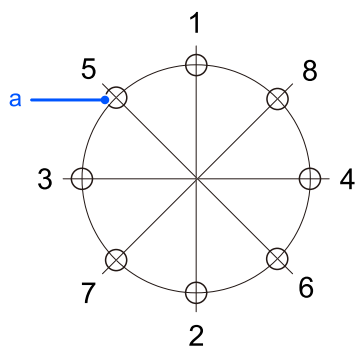

Symbol	Description
a	Threaded holes

When securing the bolts, do not tighten the bolts all at once, but tighten them in two or three separate rounds with an Allen wrench, and then use a torque wrench or similar tool to secure them at the tightening torques shown in the table above.

## 5.3 Daily Inspection of LS50-C Manipulator

Accurate inspection work is necessary to prevent breakdowns and ensure safety. This section explains the inspection schedule and what should be inspected.

Perform inspections according to the predetermined schedule.

### 5.3.1 Inspection

#### 5.3.1.1 Schedule for Inspection

Inspection items are divided into five stages (daily, 1-month, 3-month, 6-month, and 12-month), with additional items added at each stage. However, if the Manipulator is powered and operated for more than 250 hours in a month, add inspection items every 250, 750, 1500, and 3000 hours.

	Inspection Item					
	Daily Inspection	1-month Inspection	3-month Inspection	6-month Inspection	12-month Inspection	Overhaul (Parts Replacement)
1 months (250 hours)	Perform daily	✓				
2 months (500 hours)		✓				
3 months (750 hours)		✓	✓			
4 months (1,000 hours)		✓				
5 months (1,250 hours)		✓				
6 months (1,500 hours)		✓	✓	✓		
7 months (1,750 hours)		✓				
8 months (2,000 hours)		✓				
9 months (2,250 hours)		✓	✓			
10 months (2,500 hours)		✓				
11 months (2,750 hours)		✓				
12 months (3,000 hours)		✓	✓	✓	✓	
13 months (3,250 hours)		✓				
⋮	⋮	⋮	⋮	⋮	⋮	⋮

	Inspection Item					
	Daily Inspection	1-month Inspection	3-month Inspection	6-month Inspection	12-month Inspection	Overhaul (Parts Replacement)
(20,000 hours)						✓

### 5.3.1.2 Inspection point

#### Inspection item

Inspection item	Inspection Spot	Daily inspection	Monthly inspection	Quarterly inspection	Biannual inspection	Annual inspection
Check looseness or backlash of bolts/screws.	End effector mounting bolts	✓	✓	✓	✓	✓
	Manipulator mounting bolts	✓	✓	✓	✓	✓
Check looseness of connectors.	External connectors on Manipulator (on the connector plates etc.)	✓	✓	✓	✓	✓
Visually check for external defects. Clean up if necessary.	The entire Manipulator	✓	✓	✓	✓	✓
	External cables		✓	✓	✓	✓
Check for bends or improper location. Repair or place it properly if necessary.	Safeguard etc.	✓	✓	✓	✓	✓
Check the brake operation	Brake for arm #3 to #4	✓	✓	✓	✓	✓
Check whether unusual sound or vibration occurs.	Whole	✓	✓	✓	✓	✓

#### Inspection Method

Inspection Point	Inspection Method
Check looseness or backlash of bolts/screws.	Use a hexagonal wrench to check that the end effector mounting bolts and the Manipulator mounting bolts are not loose. When the bolts are loose, refer to the following and tighten them to the proper torque. <b>Tightening the hexagon socket head cap bolt</b>
Check looseness of connectors	Check that connectors are not loose. When the connectors are loose, reattach it so that it does not come off.
Visually check for external defects. Clean up if necessary.	Check the appearance of the Manipulator and clean up if necessary. Check the appearance of the cable, and if it is scratched, check that there is no cable disconnection.
Check for bends or improper location.	Check that the safeguard, etc. are located properly. If the location is improper, place it properly.

Inspection Point	Inspection Method
Check the brake operation	Check that the shaft does not fall when in MOTOR OFF. If the shaft falls when in MOTOR OFF and the brake is not released, contact the supplier. Also, if the brake is not released even after operating the brake release, contact the supplier.
Check whether unusual sound or vibration occurs.	Check that there is no unusual sound or vibration when operating. If there is something wrong, contact the supplier.

### 5.3.2 Overhaul (Parts Replacement)

Overhaul (replacement) shall be performed by properly trained service engineers.

For details, refer to the following manual.  
 "Safety Manual - Role and Training for Safety Managers"

For details on overhaul, refer to the following manual.

“Service Manual”

### 5.3.3 Greasing

The ball screw spline and reduction gear units need greasing regularly. Only use the grease specified.

**⚠ CAUTION**

- Pay attention to the amount of greasing When greasing runs out, it can cause the slide part to get damaged which may result in not only the ball screw spline and reduction gear units to not function properly but also cost an incredible amount of money and time.
- Wear protective gear including a mask, protective goggles, and oil-resistant gloves during grease up. If grease gets into your eyes, mouth, or on your skin, follow the instructions below.
  - If grease gets into your eyes  
 Flush them thoroughly with clean water, and then see a doctor immediately.
  - If grease gets into your mouth  
 If swallowed, do not induce vomiting. See a doctor immediately. If grease gets into your mouth, wash your mouth with water thoroughly.
  - If grease gets on your skin  
 Wash the area thoroughly with soap and water.

	Greasing part	Greasing Interval	Grease	How to grease
Joint #1, Joint #2	Reduction gear units	Overhaul timing	-	Greasing shall be performed by personnel who has taken a proper training. For details, refer to the Manipulator’s service manual.

	Greasing part	Greasing Interval	Grease	How to grease
Joint #3	Ball screw spline unit, support shaft	At 100 km of operation (50 km for first greasing)	AFB	Greasing the Ball Screw Spline Unit (mentioned below)

**Joint #3 ball screw spline unit and support shaft**

The recommended greasing interval is at 100 km of operation. However, greasing interval can also be checked from the grease condition. Perform greasing if the grease is discolored or becomes dry.

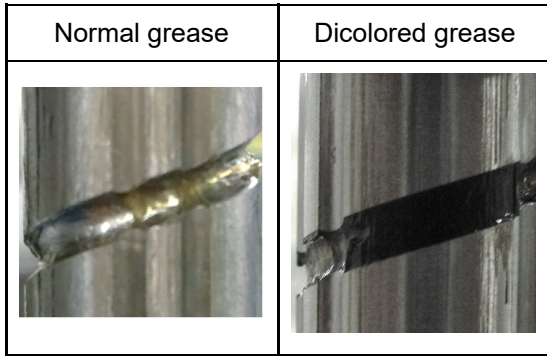

Perform greasing at 50 km of operation for the first time of greasing.

**KEY POINTS**

In Epson RC+, the recommended greasing interval is referred in Epson RC+ [Maintenance].

**Greasing the Ball Screw Spline Unit**

	Name	Qty.	Note
Grease	For Ball Screw Spline Unit (AFB grease)	Proper quantity	
Tools	Wiping cloth	1	For wiping grease (Spline shaft)
	Cross-point screwdriver	1	

**KEY POINTS**

Cover the surrounding area such as the end effector and peripheral equipment in case the grease drips.

1. Turn ON the Controller.
2. Move the shaft to its lower limit in one of the following methods.
  - Move the shaft to its lower limit manually while pressing the brake release switch.
  - Move the shaft to its lower limit from Epson RC+ [Tools]-[Robot Manager]-[Jog & Teach].

**CAUTION**

- Be sure to keep enough space and prevent the end effector hitting any peripheral equipment.
- The brake release switch affects both Joints #3 and #4. When the brake release switch is pressed, the brakes for both Joints #3 and #4 are released simultaneously. Be careful of the shaft falling and rotating

while the brake release switch is being pressed because the shaft may be lowered by the weight of the hand.

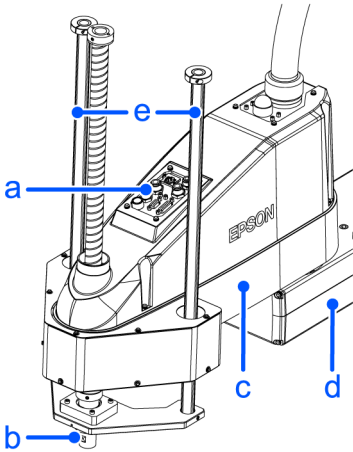

Symbol	Description
a	Joint #3 #4 Brake release switch
b	Shaft
c	Arm #2
d	Arm #1
e	Support shaft

3. Turn off the Controller.
4. Wipe off the old grease from the shaft, and then apply new grease to it.

The grease application area is from the end of the shaft spline nut to the mechanical stop and the entire side of the support shaft.

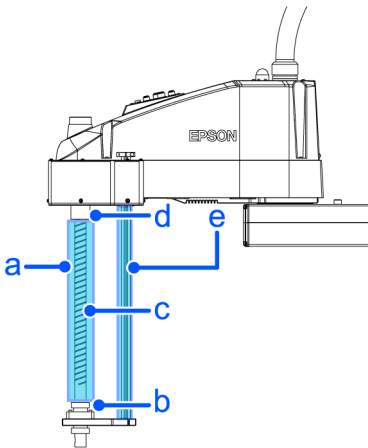

Symbol	Description
a	Grease application range
b	Mechanical stop
c	Shaft

Symbol	Description
d	End of the spline nut
e	Support shaft

5. Grease should be applied to the helical and vertical grooves of the shaft so that the grooves are filled evenly.

Grease application example:



6. Turn on the Controller.

7. Start the robot manager and move the shaft to the origin position.

Be careful not to hit peripheral equipment.

8. After moving to the origin position, reciprocate the shaft. The reciprocating operation is a low power mode operation program that performs from the upper limit to the lower limit. Run for about 5 minutes to spread the grease over the shaft.

9. Turn off the Controller.

10. Wipe off any excess grease at the end of the spline nut, mechanical stop, and the support shaft.

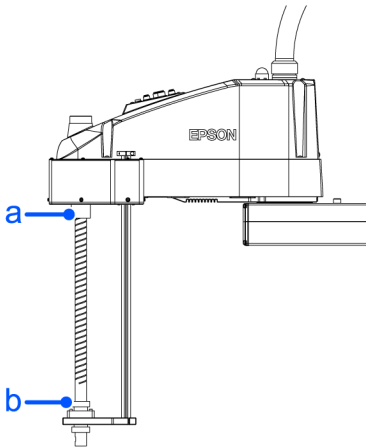

Symbol	Description
a	End of the spline nut
b	Mechanical stop

### 5.3.4 Tightening the hexagon socket head cap bolt

Hexagon socket head cap bolts (referred to as "bolts" below) are used in locations where mechanical strength is required. During assembly, these bolts are tightened at the tightening torques shown in the following table.

Unless otherwise specified, when retightening these bolts in the work procedures described in this manual, use a torque wrench or similar tool to obtain the tightening torques in the following table.

Bolt	Tightening Torque
M3	2.0 ± 0.1 N·m (21 ± 1 kgf·cm)
M4	4.0 ± 0.2 N·m (41 ± 2 kgf·cm)
M5	8.0 ± 0.4 N·m (82 ± 4 kgf·cm)
M6	13.0 ± 0.6 N·m (133 ± 6 kgf·cm)
M8	32.0 ± 1.6 N·m (326 ± 16 kgf·cm)
M10	58.0 ± 2.9 N·m (590 ± 30 kgf·cm)
M12	100.0 ± 5.0 N·m (1,020 ± 51 kgf·cm)

For set screw, refer to the following table.

Set Screw	Tightening Torque
M4	2.4 ± 0.1 N·m (26 ± 1 kgf·cm)
M5	3.9 ± 0.2 N·m (40 ± 2 kgf·cm)
M6	8.0 ± 0.4 N·m (82 ± 4 kgf·cm)

It is recommended that bolts arranged in a circular pattern be secured in place by tightening in criss-cross order as shown in the figure.

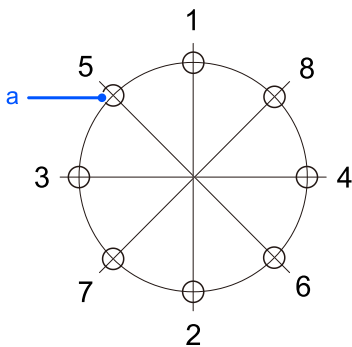

Symbol	Description
a	Threaded holes

When securing the bolts, do not tighten the bolts all at once, but tighten them in two or three separate rounds with an Allen wrench, and then use a torque wrench or similar tool to secure them at the tightening torques shown in the table above.

## 6. Appendix

Stopping time and Stopping distance in Emergency based on each model.

## 6.1 Appendix A: Included Items

### 6.1.1 LS4-C Included Items

The following items are included with the Manipulator when shipped from the factory

Name	Model type	Number
CONNECTOR	DB-15MKAC00B0	2
CONNECTOR ACCESSORY	C03-15CLACAA0	2

### 6.1.2 LS8-C Included Items

The following items are included with the Manipulator when shipped from the factory

Name	Model type	Number
CONNECTOR	DB-15MKAC00B0	2
CONNECTOR ACCESSORY	C03-15CLACAA0	2

### 6.1.3 LS20-C Included Items

The following items are included with the Manipulator when shipped from the factory

Name	Model type	Number
CONNECTOR/DA-15PF-N	DA-15PF-N	2
CONNECTOR	DE-9PF-N	2
CONNECTOR ACCESSORY	HDE-CTH(4-40)(10)	2
CONNECTOR ACCESSORY	HDA-CTH(4-40)(10)	2
EYE BOLT	B-130-8	2

### 6.1.4 LS50-C Included Items

The following items are included with the Manipulator when shipped from the factory

Name	Model type	Number
CONNECTOR	DA-15PF-N	2
CONNECTOR	DE-9PF-N	2
CONNECTOR ACCESSORY	HDE-CTH(4-40)(10)	2
CONNECTOR ACCESSORY	HDA-CTH(4-40)(10)	2
EYE BOLT	B-130-8	2

## 6.2 Appendix B: Specification Table

### 6.2.1 LS4-C Specification Table

Item		LS4-C401*
Machinery names		Industrial Robot
Product series		LS
Model		LS4-C401* <b>Model number</b>
Installation method		Base table mounting type
Arm length	Arm #1 + Arm #2	400 mm
	Arm #1	225 mm
	Arm #2	175 mm
Max. operating speed *1	Joint #1+ #2	7200 mm/s
	Joint #3	1100 mm/s
	Joint #4	2600 °/s
Repeatability	Joint #1+ #2	± 0.01 mm
	Joint #3	± 0.01 mm
	Joint #4	± 0.01°
Payload (Load)	Rating	2 kg
	Max.	4 kg
Joint #4 allowable moment of inertia *2	Rating	0.005 kg·m <sup>2</sup>
	Max.	0.05 kg·m <sup>2</sup>
Resolution	Joint #1	0.000439 °/pulse
	Joint #2	0.000439 °/pulse
	Joint #3	0.000799 mm/pulse
	Joint #4	0.002177 °/pulse
Hand diameter	Mounting	∅ 16 mm
	Through hole	∅ 11 mm
Mounting hole		120 × 120 mm 135 × 120 mm (Both are acceptable)
		4-M8
Weight (cables not included)		14 kg (31 lbs.)
Driving method	All joints	AC servo motor

Item		LS4-C401*	
Motor rated capacity	Joint #1	400 W	
	Joint #2	150 W	
	Joint #3	150 W	
	Joint #4	150 W	
Option	Installation Environment	Cleanroom+ ESD *3	
Joint #3 insertion force		100 N	
Installed wire for customer use		15 (15 pin: D-sub) Equivalent to 8 pin (RJ45) Cat.5e	
Installed tubes for customer use		2 · pneumatic tubes (ø6 mm): 0.59 MPa (6kgf/cm <sup>2</sup> : 86 psi)	
		1 · pneumatic tubes (ø4 mm): 0.59 MPa (6kgf/cm <sup>2</sup> : 86 psi)	
Environmental Requirements	Ambient Temp *4	5 to 40°C	
	Ambient relative humidity	10 to 80 % (no condensation)	
Noise level *5		L <sub>Aeq</sub> = Less than 70 dB (A)	
Applicable Controller		RC800-A	
Operation mode *6		Standard mode (default), boost mode *7	
Assignable values ( ) Default values	Speed	1 to (4) to 100	
	Accel *8	1 to (10) to 120	
	SpeedS	0.1 to (50) to 2000	
	AccelS	0.1 to (200) to 25000	
	Fine	0 to (1250) to 65535	
	Weight	0 to (2) to 4	
M/C cable	Cable weight (only cables)	For fixing, signal	0.06 kg/m
		For fixing, power	0.30 kg/m
		For movable use, signal	0.07 kg/m
		For movable use, power	0.36 kg/m
	Cable Diameter	For fixing, signal	ø6.2 mm (typ)
		For fixing, power	ø13.7 mm (typ)
		For movable use, signal	ø6.4 mm (typ)
		For movable use, power	ø13.7 mm (typ)

Item		LS4-C401*	
	Minimum bending radius *9	For fixing, signal	39 mm
		For fixing, power	83 mm
		For movable use, signal	100 mm
		For movable use, power	100 mm

Item		LS4-C401S	LS4-C401C
Max. motion range	Joint #1	± 132°	
	Joint #2	± 141°	
	Joint #3	150 mm	120 mm
	Joint #4	± 360° * 10	
Max. pulse range (pulse)	Joint #1	-95574 to 505174	-95574 to 505174
	Joint #2	± 320854	
	Joint #3	-187734 to 0	-150187 to 0
	Joint #4	± 165376	

\*1: In the case of PTP command. Maximum operating speed for CP command is 2000 mm/s on horizontal plane.

\*2: In the case where the center of gravity is at the center of Joint #4

If the center of gravity is not at the center of Joint #4, set the parameter using INERTIA setting.

\*3: The cleanroom environment specification manipulator exhausts the inside of the base and the arm cover together. Therefore, when there is a gap in the base part, not enough negative pressure will be applied to the end of the arm, which may cause dust emission.

- Cleanroom level: Class ISO 4 (ISO14644-1)
- Exhaust:
  - Exhaust port dimension: internal diameterø12 mm
  - Compatible exhaust tube:
    - Polyurethane Tube
    - Outer diameterø 12 mm (internal diameterø8 mm)
    - Recommended amount of exhaust: About 1000cm<sup>3</sup>/s (standard state)

\*4: When the product is used in a low temperature environment around the minimum temperature of the product specification, or when the product is suspended for a long time on holidays or at night, a collision detection error may occur due to the large resistance of the drive unit immediately after the start of operation. In such case, it is recommended to warm up for about 10 minutes.

\*5: Conditions of Manipulator during measurement as follows:

- Operating conditions : Under rated load, 4-joints simultaneous motion, maximum speed, maximum acceleration/deceleration, 100% duty

- Measuring position: Five directions (front, back, left, right, top), 1m from the surface of the device, at the height where the maximum operating noise occurs.

\*Definition of the surface of the device: The smallest rectangular parallelepiped (equivalent to the "reference box" in JIS Z 8737-1) that encompasses the range in which the robot operates at maximum operating noise.

\*6: The operation mode can be switched with the PerformMode command. For details, refer to the following manual.

“Epson RC+ SPEL+ Language Reference”

Compared to the standard mode the operating time for the boost mode will be shorter but vibration during the operation duty and operation stopping time will get worse. Be careful about that.

\*7: More than AC200V is recommended in boost mode. If AC180V is used, it will not be able to function at its best and an error may occur.

\*8: In general use, Accel setting 100 is the optimum setting that maintains the balance of acceleration and vibration when positioning. Although values larger than 100 can be set to Accel, it is recommended to minimize the use of large values to necessary motions since operating the manipulator continuously with the large Accel setting may shorten the product life remarkably.

\*9: When wiring a movable M/C cable, be careful of the following:

- Install the cable so that it does not put pressure on the connector part.
- Bend the cable at or above the minimum bending radius of the movable part. The bending radius (A) is the dimension shown in the diagram below.

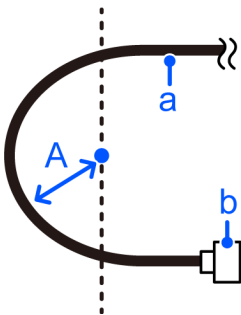

Symbol	Description
a	M/C Cables
b	Connector

**KEY POINTS**

You cannot use the SFree command to J3 and J4.

\*10 Multi-rotation is possible up to ±10 rotations or more. For details on the maximum number of rotation, please contact the supplier.

## 6.2.2 LS8-C Specification Table

Item		LS8-C502 *	LS8-C602 *	LS8-C702*
Machinery names		Industrial Robot		
Product series		LS		
Model		LS8-C*02* <b>Model number</b>		
Installation method		Base table mounting type		
Arm length	Arm #1 + Arm #2	500 mm	600 mm	700 mm
	Arm #1	225 mm	325 mm	425 mm
	Arm #2	275 mm		
Max. operating speed *1	Joint #1+ #2	7120 mm/s	7850 mm/s	8590 mm/s
	Joint #3	1100 mm/s		
	Joint #4	2000 °/s		
Repeatability	Joint #1+ #2	± 0.02 mm		
	Joint #3	± 0.01 mm		
	Joint #4	± 0.01°		
Payload (Load)	Rating	3 kg		
	Max.	8 kg		
Joint #4 allowable moment of inertia *2	Rating	0.01 kg·m <sup>2</sup>		
	Max.	0.12 kg·m <sup>2</sup>		
Resolution	Joint #1 (°/pulse)	0.000275		
	Joint #2 (°/pulse)	0.000439		
	Joint #3 (mm/pulse)	0.0007324		
	Joint #4 (°/pulse)	0.001465		
Hand diameter	Mounting	ø 20 mm		
	Through hole	ø 14 mm		
Mounting hole	150 × 150 mm			
	4-M8			
Weight (cables not included)		19 kg (42 lbs.)	20 kg (44 lbs.)	21 kg (46 lbs.)
Driving method	All joints	AC servo motor		
Motor rated capacity	Joint #1	400 W		
	Joint #2	400 W		
	Joint #3	150 W		

Item		LS8-C502 *	LS8-C602 *	LS8-C702*
	Joint #4	150 W		
Option	Installation Environment	Cleanroom+ ESD *3		
Joint #3 insertion force		100 N		
Installed wire for customer use		15 (15 pin: D-sub) Equivalent to 8 pin (RJ45) Cat.5e		
Installed tubes for customer use		2 ·pneumatic tubes (ø6 mm): 0.59 MPa (6kgf/cm <sup>2</sup> : 86 psi)		
		1 ·pneumatic tubes (ø4 mm): 0.59 MPa (6kgf/cm <sup>2</sup> : 86 psi)		
Environmental Requirements	Ambient Temp *4	5 to 40°C		
	Ambient relative humidity	10 to 80 % (no condensation)		
Noise level *5		L <sub>Aeq</sub> = Less than 70 dB (A)		
Applicable Controller		RC800-A		
Operation mode *6		Standard mode (default), boost mode *7		
Assignable values ( ) Default values	Speed	1 to (5) to 100		
	Accel *8	1 to (10) to 120		
	SpeedS	0.1 to (50) to 2000		
	AccelS	0.1 to (200) to 25000		
	Fine	0 to (1250) to 65535		
	Weight	0 to (3) to 8		
M/C cable	Cable weight (only cables)	For fixing, signal	0.06 kg/m	
		For fixing, power	0.30 kg/m	
		For movable use, signal	0.07 kg/m	
		For movable use, power	0.36 kg/m	
	Cable Diameter	For fixing, signal	ø6.2 mm (typ)	
		For fixing, power	ø13.7 mm (typ)	
		For movable use, signal	ø6.4 mm (typ)	
		For movable use, power	ø13.7 mm (typ)	
	Minimum bending radius *9	For fixing, signal	39 mm	
		For fixing, power	83 mm	
		For movable use, signal	100 mm	

Item		LS8-C502 *	LS8-C602 *	LS8-C702*
		For movable use, power		
		100 mm		

Item		LS8-C*02S	LS8-C*02C
Max. motion range	Joint #1	± 132°	
	Joint #2	± 150°	
	Joint #3	200 mm	170 mm
	Joint #4	± 360° * 10	
Max. pulse range (pulse)	Joint #1	-152918 to 808278	
	Joint #2	± 341334	
	Joint #3	-273067 to 0	-232107 to 0
	Joint #4	± 245761	

\*1: In the case of PTP command. Maximum operating speed for CP command is 2000 mm/s on horizontal plane.

\*2: In the case where the center of gravity is at the center of Joint #4. If the center of gravity is not at the center of Joint #4, set the parameter using INERTIA setting.

\*3: The cleanroom environment specification manipulator exhausts the inside of the base and the arm cover together. Therefore, when there is a gap in the base part, not enough negative pressure will be applied to the end of the arm, which may cause dust emission.

- Cleanroom level: Class ISO 4 (ISO14644-1)
- Exhaust:
  - Exhaust port dimension: internal diameterø12 mm
  - Compatible exhaust tube:
    - Polyurethane Tube
    - Outer diameterø 12 mm (internal diameterø8 mm)
    - Recommended amount of exhaust: About 1000cm<sup>3</sup>/s (Standard state)

\*4: When the product is used in a low temperature environment around the minimum temperature of the product specification, or when the product is suspended for a long time on holidays or at night, a collision detection error may occur due to the large resistance of the drive unit immediately after the start of operation. In such case, it is recommended to warm up for about 10 minutes.

\*5: Conditions of Manipulator during measurement as follows:

- Operating conditions : Under rated load, 4-joints simultaneous motion, maximum speed, maximum acceleration/deceleration, 100% duty
- Measuring position: Five directions (front, back, left, right, top), 1m from the surface of the device, at the height where the maximum operating noise occurs.

\*Definition of the surface of the device: The smallest rectangular parallelepiped (equivalent to the "reference box" in JIS Z 8737-1) that encompasses the range in which the robot operates at maximum operating noise.

\*6: The operation mode can be switched with the PerformMode command. For details, refer to the following manual.

“Epson RC+ SPEL+ Language Reference”

Compared to the standard mode the operating time for the boost mode will be shorter but vibration during the operation duty and operation stopping time will get worse. Be careful about that.

\*7: More than AC200V is recommended in boost mode. If AC180V is used, it will not be able to function at its best and an error may occur.

\*8: In general use, Accel setting 100 is the optimum setting that maintains the balance of acceleration and vibration when positioning. Although values larger than 100 can be set to Accel, it is recommended to minimize the use of large values to necessary motions since operating the manipulator continuously with the large Accel setting may shorten the product life remarkably.

\*9: When wiring a movable M/C cable, be careful of the following:

- Install the cable so that it does not put pressure on the connector part.
- Bend the cable at or above the minimum bending radius of the movable part. The bending radius (A) is the dimension shown in the diagram below.

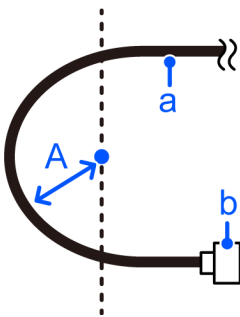

Symbol	Description
a	M/C Cables
b	Connector

**KEY POINTS**

You cannot use the SFree command to J3 and J4.

\*10 Multi-rotation is possible up to ±10 rotations or more. For details on the maximum number of rotation, please contact the supplier.

### 6.2.3 LS20-C Specification Table

Item		LS20-C804 *	LS20-CA04*
Machinery names		Industrial Robot	
Product series		LS	
Model		LS20-C**** <b>Model number</b>	
Installation method		Base table mounting type	
Arm length	Arm #1 + Arm #2	800 mm	1000 mm
	Arm #1	350 mm	550 mm
	Arm #2	450 mm	
Max. operating speed *1	Joint #1+ #2	9940 mm/s	11250 mm/s
	Joint #3	2300 mm/s	
	Joint #4	1400 °/s	
Repeatability	Joint #1+ #2	± 0.025 mm	
	Joint #3	± 0.01 mm	
	Joint #4	± 0.01°	
Payload (Load)	Rating	10 kg	
	Max.	20 kg	
Joint #4 allowable moment of inertia *2	Rating	0.05 kg·m <sup>2</sup>	
	Max.	1.00 kg·m <sup>2</sup>	
Resolution	Joint #1	0.000275 °/pulse	
	Joint #2	0.000439 °/pulse	
	Joint #3	0.00148 mm/pulse	
	Joint #4	0.001046 °/pulse	
Hand diameter	Mounting	∅ 25 mm	
	Through hole	∅ 18 mm	
Mounting hole		200 × 200 mm	
		4 × ∅16	
Weight (cables not included)		48 kg: 105.8 lbs. (pound)	51 kg: 112.5 lbs. (pound)
Driving method	All joints	AC servo motor	
Motor rated capacity	Joint #1	750 W	
	Joint #2	600 W	
	Joint #3	400 W	

Item		LS20-C804 *	LS20-CA04*
	Joint #4	150 W	
Option	Installation Environment	Cleanroom *3	
Joint #3 insertion force		250 N	
Installed wire for customer use		15 pin: D-sub, 9 pin: D-sub Equivalent to 8 pin (RJ45) Cat.5e	
Installed tubes for customer use		2 pneumatic tubes (ø8 mm): 0.59 MPa (6kgf/cm <sup>2</sup> : 86 psi)	
		2 pneumatic tubes (ø6 mm): 0.59 MPa (6kgf/cm <sup>2</sup> : 86 psi)	
Environmental Requirements	Ambient Temp *4	5 to 40°C	
	Ambient relative humidity	10 to 80 % (no condensation)	
Noise level *5		L <sub>Aeq</sub> = 74.5 dB (A) or under	
Applicable Controller		RC800-A	
Assignable values ( ) Default values	Speed	1 to (3) to 100	
	Accel *6	1 to (10) to 120	
	SpeedS	0.1 to (50) to 2000	
	AccelS	0.1 to (200) to 10000	
	Fine	0 to (1250) to 65535	
	Weight	0,450 to (10,450) to 20450	
M/C cable	Cable weight (only cables)	For fixing, signal	0.06 kg/m
		For fixing, power	0.30 kg/m
		For movable use, signal	0.07 kg/m
		For movable use, power	0.36 kg/m
	Cable Diameter	For fixing, signal	ø6.2 mm (typ)
		For fixing, power	ø13.7 mm (typ)
		For movable use, signal	ø6.4 mm (typ)
		For movable use, power	ø13.7 mm (typ)
	Minimum bending radius *7	For fixing, signal	39 mm
		For fixing, power	83 mm
		For movable use, signal	100 mm
		For movable use, power	100 mm

Item		LS20-C804S	LS20-CA04S	LS20-C804C	LS20-CA04C
Max. motion range	Joint #1	± 132°			
	Joint #2	± 152°			
	Joint #3	420 mm		390 mm	
	Joint #4	± 360° * 8			
Max. pulse range (pulse)	Joint #1	-152918 to 808278			
	Joint #2	± 345885			
	Joint #3	-283853 to 0		-263578~0	
	Joint #4	± 344064			

\*1: In the case of PTP command. Maximum operating speed for CP command is 2000 mm/s on horizontal plane.

\*2: In the case where the center of gravity is at the center of Joint #4. If the center of gravity is not at the center of Joint #4, set the parameter using Inertia setting.

\*3: The cleanroom environment specification manipulator exhausts the inside of the base and the arm cover together. Therefore, when there is a gap in the base part, not enough negative pressure will be applied to the end of the arm, which may cause dust emission.

- Cleanroom level: Class ISO 4 (ISO14644-1)
- Exhaust:
  - Exhaust port dimension: internal diagramø12 mm
  - Compatible exhaust tube: Polyurethane Tube
  - Outer diameterø 12 mm (internal diameterø8 mm)
  - Recommended amount of exhaust: About 1000cm<sup>3</sup>/s (Standard state)

\*4: When the product is used in a low temperature environment around the minimum temperature of the product specification, or when the product is suspended for a long time on holidays or at night, a collision detection error may occur due to the large resistance of the drive unit immediately after the start of operation. In such case, it is recommended to warm up for about 10 minutes.

\*5: Conditions of Manipulator during measurement as follows:

- Operating conditions : Under rated load, 4-joints simultaneous motion, maximum speed, maximum acceleration/deceleration, 100% duty
- Measuring position: Five directions (front, back, left, right, top), 1m from the surface of the device, at the height where the maximum operating noise occurs.

\*Definition of the surface of the device: The smallest rectangular parallelepiped (equivalent to the "reference box" in JIS Z 8737-1) that encompasses the range in which the robot operates at maximum operating noise.

\*6: In general use, Accel setting 100 is the optimum setting that maintains the balance of acceleration and vibration when positioning. Although values larger than 100 can be set to Accel, it is recommended to minimize the use of large values to necessary motions since operating the manipulator continuously with the large Accel setting may shorten the product life remarkably.

\*7: When wiring a movable M/C cable, be careful of the following:

- Install the cable so that it does not put pressure on the connector part.

- Bend the cable at or above the minimum bending radius of the movable part. The bending radius (A) is the dimension shown in the diagram below.

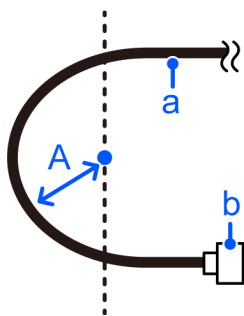

Symbol	Description
a	M/C Cables
b	Connector

### KEY POINTS

You cannot use the SFree command to J3 and J4.

\*8 Multi-rotation is possible up to  $\pm 10$  rotations or more. For details on the maximum number of rotation, please contact the supplier.

## 6.2.4 LS50-C Specification Table

Item		LS50-CA02S	LS50-CA04S
Machinery names		Industrial Robot	
Product series		LS	
Model		LS50-CA0*S <b>Model number</b>	
Installation method		Base table mounting type	
Arm length	Arm #1 + Arm #2	1000 mm	
	Arm #1	550 mm	
	Arm #2	450 mm	
Max. operating speed *1	Joint #1+ #2	6100 mm/s	
	Joint #3	770 mm/s	
	Joint #4	660°/s	
Repeatability	Joint #1+ #2	± 0.05 mm	
	Joint #3	± 0.02 mm	
	Joint #4	± 0.01°	
Payload (Load)	Rating	30 kg	
	Max.	50 kg	
Joint #4 allowable moment of inertia *2	Rating	1.0 kg·m <sup>2</sup>	
	Max.	2.45 kg·m <sup>2</sup>	
Resolution	Joint #1	0.000182°/pulse	
	Joint #2	0.000275°/pulse	
	Joint #3	0.000496 mm/pulse	
	Joint #4	0.000488°/pulse	
Hand diameter	Mounting	ø 25 mm	
	Through hole	ø 18 mm	
Mounting hole	200× 200 mm		
	4 × ø16		
Weight (cables not included)		60 kg: 132.3 lbs. (pound)	61 kg: 134.5 lbs. (pound)
Driving method	All joints	AC servo motor	
Motor rated capacity	Joint #1	750 W	
	Joint #2	600 W	
	Joint #3	400 W	

Item		LS50-CA02S	LS50-CA04S
	Joint #4	150 W	
Installed wire for customer use		15 pin: D-sub, 9 pin: D-sub	
		Equivalent to 8 pin (RJ45) Cat.5e	
Installed tubes for customer use		2 pneumatic tubes (ø8 mm): 0.59 MPa (6kgf/cm <sup>2</sup> : 86 psi)	
		2 pneumatic tubes (ø6 mm): 0.59 MPa (6kgf/cm <sup>2</sup> : 86 psi)	
Environmental Requirements	Ambient Temp *3	5 to 40 °C	
	Ambient relative humidity	10 to 80 % (no condensation)	
Ambient relative humidity *4		LAeq = 70 dB (A) or under	
Applicable Controller		RC800-A	
Assignable Value ( ) Default values	Speed	1 to (3) to 100	
	Accel *5	1 to (10) to 120	
	SpeedS	0.1 to (50) to 1700	
	AccelS	0.1 to (200) to 14000	
	Fine	0 ~ (1250) ~ 65535	
	Weight	0,450 ~ (50,450) ~ 50450	
M/C cable	Cable weight (only cables)	For fixing, signal	0.06 kg/m
		For fixing, power	0.30 kg/m
		For movable use, signal	0.07 kg/m
		For movable use, power	0.36 kg/m
	Cable Diameter	For fixing, signal	6.2 mm (typ)
		For fixing, power	ø13.7 mm (typ)
		For movable use, signal	ø6.4 mm (typ)
		For movable use, power	ø13.7 mm (typ)
	Minimum bending radius *6	For fixing, signal	39 mm
		For fixing, power	83 mm
		For movable use, signal	100 mm
		For movable use, power	100 mm

Item		LS50-BA02S	LS50-BA04S
Max. motion range	Joint #1	± 132°	
	Joint #2	± 135°	
	Joint #3	210 mm	400 mm

Item		LS50-BA02S	LS50-BA04S
	Joint #4	$\pm 360^\circ *7$	
Max. pulse range (pulse)	Joint #1	- 231288 ~ 1222520	
	Joint #2	$\pm 491520$	
	Joint #3	-423464~0	-806597 ~ 0
	Joint #4	$\pm 737281$	

\*1: In the case of PTP command. Maximum operating speed for CP command is 1700 mm/s on horizontal plane.

\*2: In the case where the center of gravity is at the center of Joint #4. If the center of gravity is not at the center of Joint #4, set the parameter using Inertia setting.

\*3: When the product is used in a low temperature environment around the minimum temperature of the product specification, or when the product is suspended for a long time on holidays or at night, a collision detection error may occur due to the large resistance of the drive unit immediately after the start of operation. In such case, it is recommended to warm up for about 10 minutes.

\*4: Conditions of Manipulator during measurement as follows:

- Operating conditions : Under rated load, 4-joints simultaneous motion, maximum speed
- Measurement point: Rear of the Manipulator, 1000 mm apart from the motion range, 50 mm above the base-installed surface.

\*5: In general use, Accel setting 100 is the optimum setting that maintains the balance of acceleration and vibration when positioning. Although values larger than 100 can be set to Accel, it is recommended to minimize the use of large values to necessary motions since operating the manipulator continuously with the large Accel setting may shorten the product life remarkably.

\*6: When wiring a movable M/C cable, be careful of the following:

- Install the cable so that it does not put pressure on the connector part.
- Bend the cable at or above the minimum bending radius of the movable part. The bending radius (A) is the dimension shown in the diagram below.

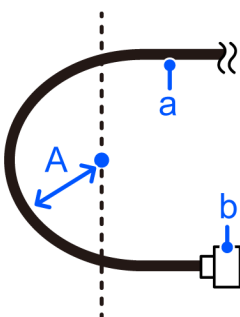

Symbol	Description
a	M/C Cables
b	Connector

 **KEY POINTS**

You cannot use the SFree command to J3 and J4.

\*7 Multi-rotation is possible up to  $\pm 10$  rotations or more. For details on the maximum number of rotation, please contact the supplier.

## 6.3 Appendix C: Stopping time and Stopping distance in Emergency

The stopping time and stopping distance in emergency stop are shown in a graph for each model.

The stopping time is “Stopping time” in the figure below. Be sure to confirm that safety is ensured according to the installation environment and operation of the robot.

The stopping time and stopping distance of a safety limited speed, safety limited position, and soft axis limit is equivalent to that of the emergency stop for models equipped with Safety Boards such as RC700-E and RC800A.

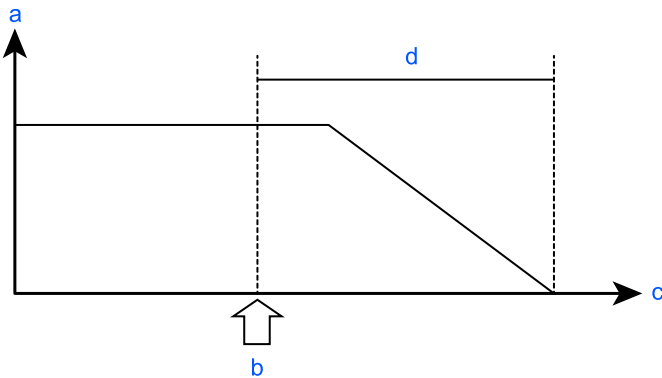

Symbol	Description
a	Motor speed
b	Emergency stop, Maximum Speed of SLS exceeded, monitoring areas and Joint Angle Limit of SLP exceeded, restricted range of Soft Axis Limiting exceeded
c	Time
d	Stopping Time

### Conditions

The stopping time and stopping distance vary depending on the parameters (setting value) set for the robot. These graphs show the time and distance for the following parameters.

These conditions are determined based on the ISO 10218-1:2011 Annex B.

- Accel : 100, 100
- Speed: 100 %, 66 %, 33 % setting
- Weight: 100 %, 66 %, 33 % of the maximum payload, rated payload
- Arm elongation rate: 100 %, 66 %, 33 % \*1
- Other: Default
- Motion: Singular axis motion of the Go command
- Input timing of the Stop signal: Input with maximum speed. In this motion, it is the center of the motion range.

\*1 The arm elongation rate when J1 is operating: Arm elongation rate 0 is as shown in the figure below.

Among the following arm elongation rate, the results with the longest stopping time and stopping distance are shown in the graph.

When J2 is operating, J3 is 0 mm.

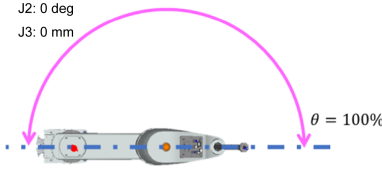
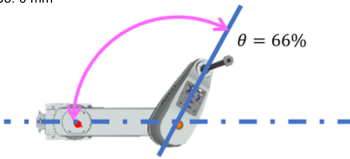
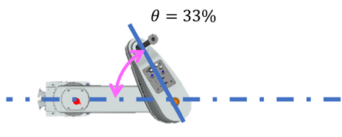
Axis	$\theta = 100\%$	$\theta = 66\%$	$\theta = 33\%$
J1	<p>J2: 0 deg J3: 0 mm</p>  <p><math>\theta = 100\%</math></p>	<p>J2: 60 deg J3: 0 mm</p>  <p><math>\theta = 66\%</math></p>	<p>J2: 120 deg J3: 0 mm</p>  <p><math>\theta = 33\%</math></p>

### Description of legend

The graph is shown for each Weight value (rated payload, 100%, about 66%, and about 33% of the maximum payload).

- Horizontal axis: Arm speed (Speed value)
- Vertical axis: Stopping time and stopping distance in each arm speed
- Time (sec): Stopping time (sec)
- Distance (deg): J1 and J2 stopping distance (degree)
- Distance [mm]: Stopping distance of J3

When single failures are taken into account, the following adjustments are used.

- Stopping distance and angle: Reaches the mechanical stop of each axis
- Stopping Time: Add 500 ms

### 6.3.1 Stopping Time and Stopping Distance in Emergency

#### LS4-C401\*: J1

Standard mode

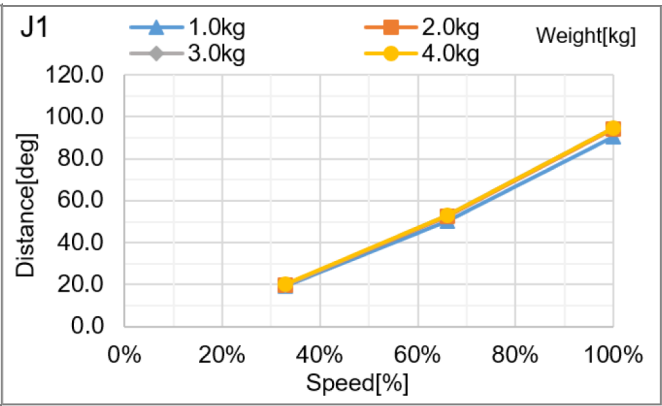
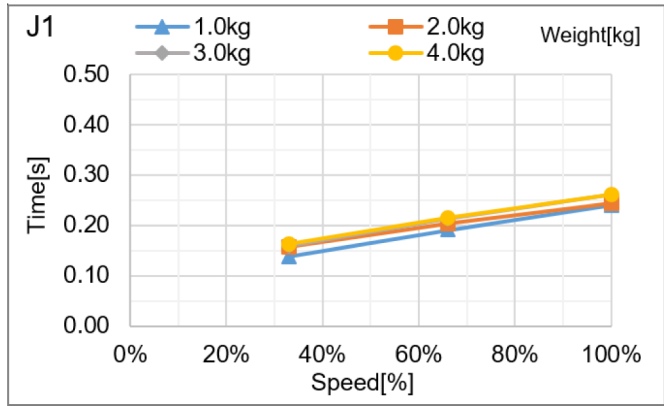

Boost mode

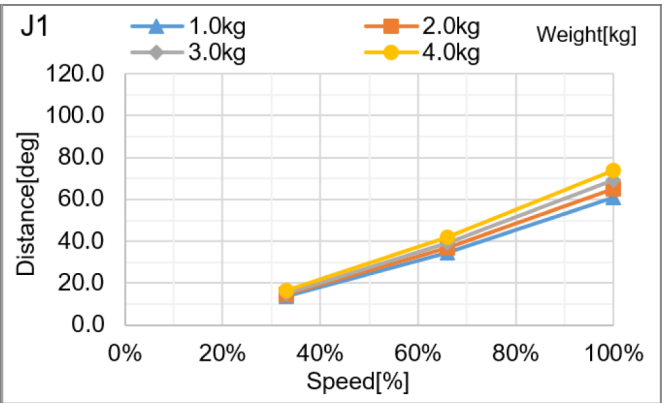
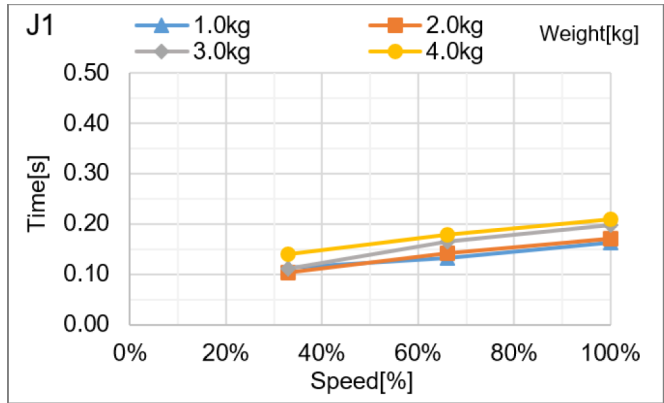

**LS4-C401\*: J2**

Standard mode

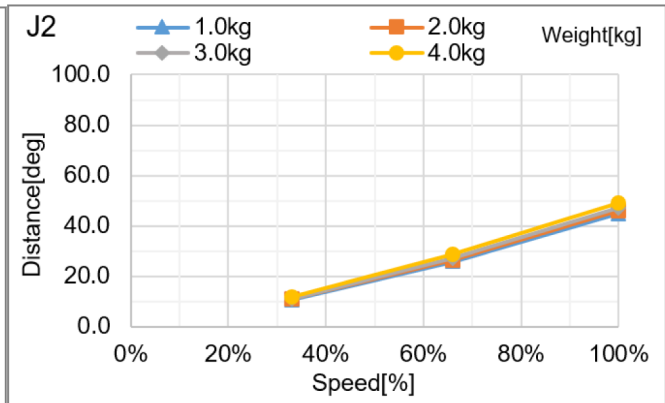
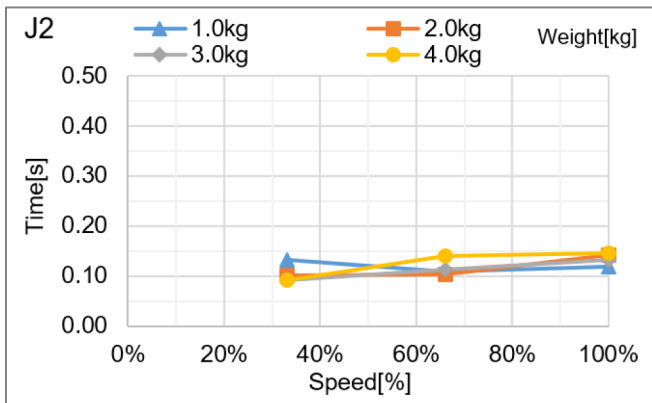

Boost mode

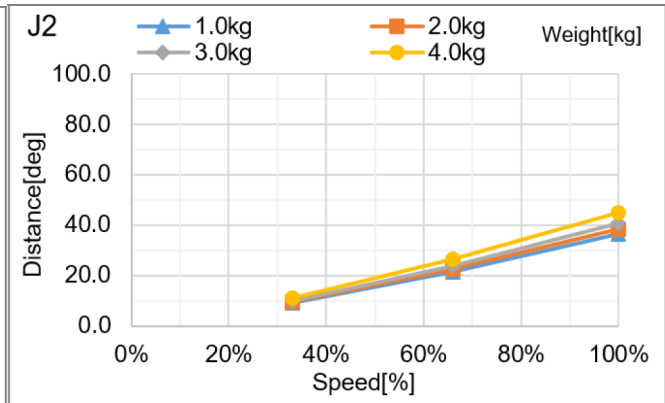
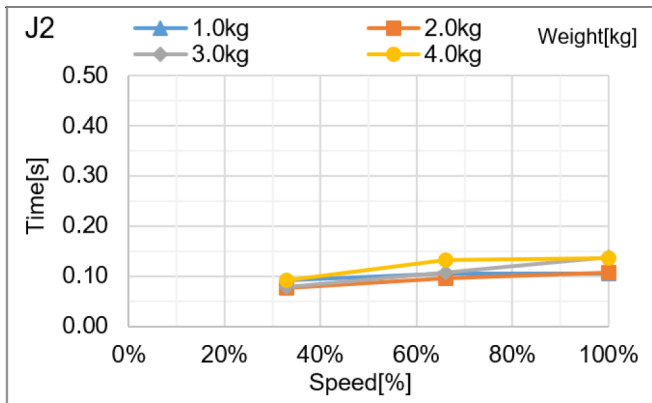

**LS4-C401\*: J3**

Standard mode

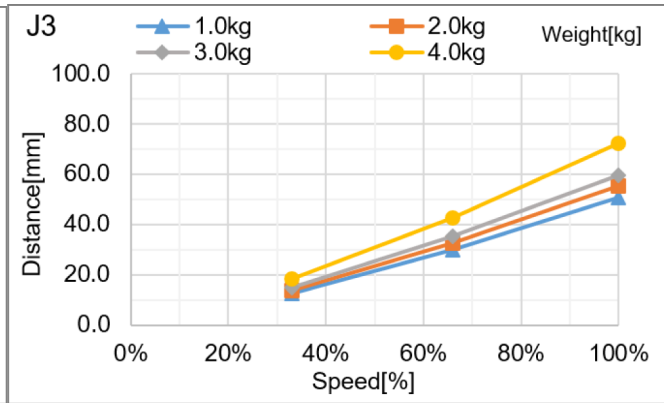
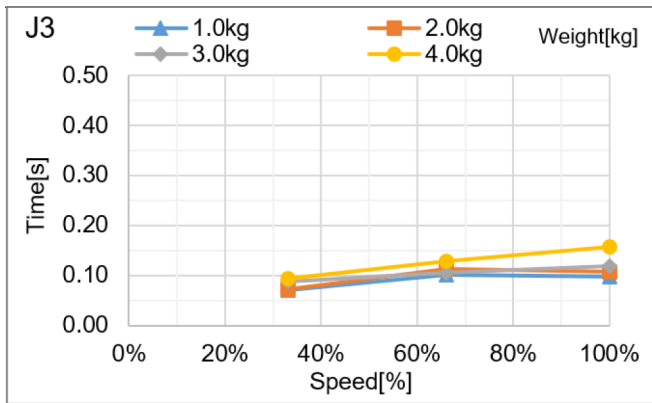

Boost mode

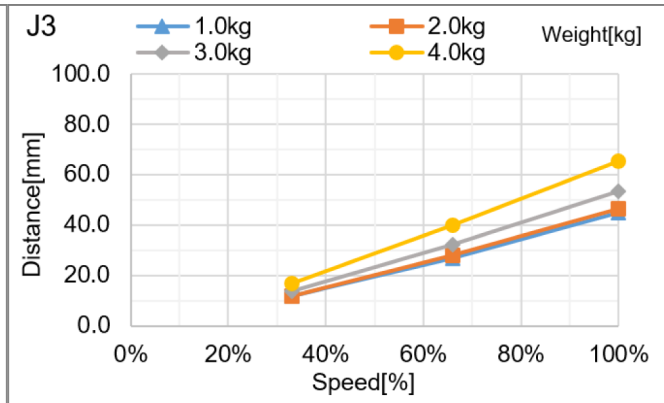
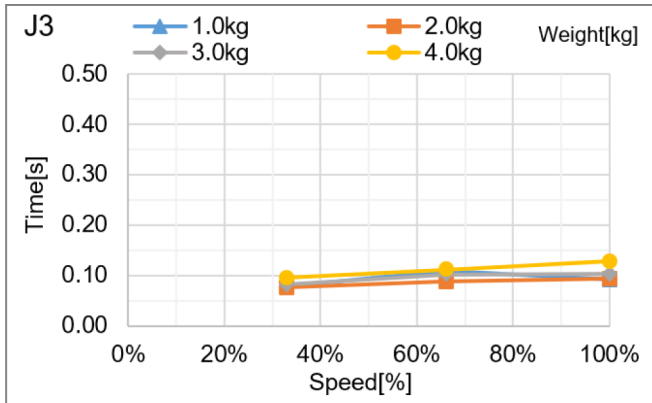

### 6.3.2 LS8-C Stopping Time and Stopping Distance in Emergency

#### LS8-C502\*: J1

Standard mode

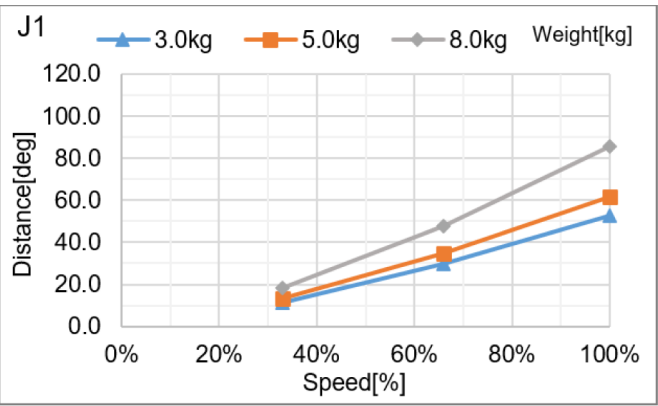
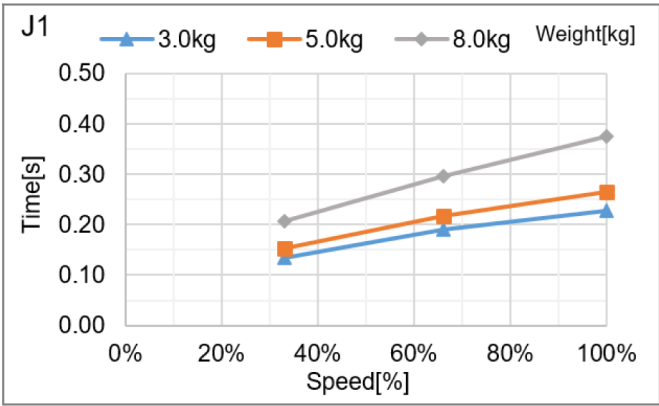

Boost mode

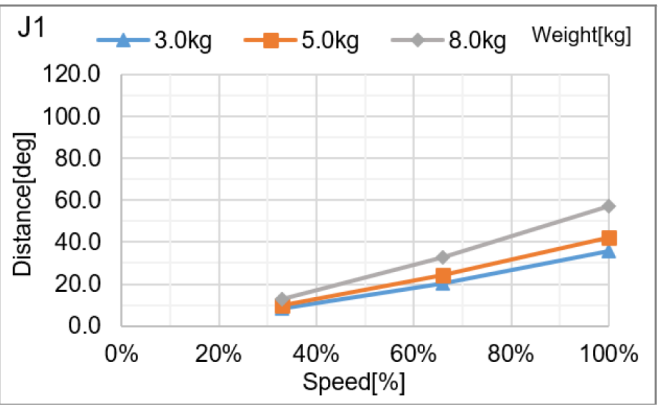
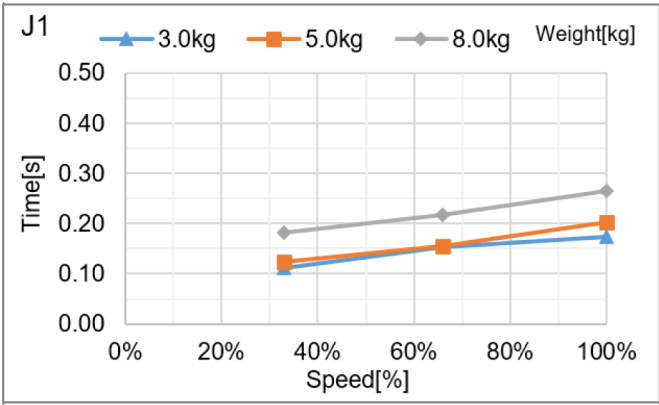

**LS8-C502\*: J2**

Standard mode

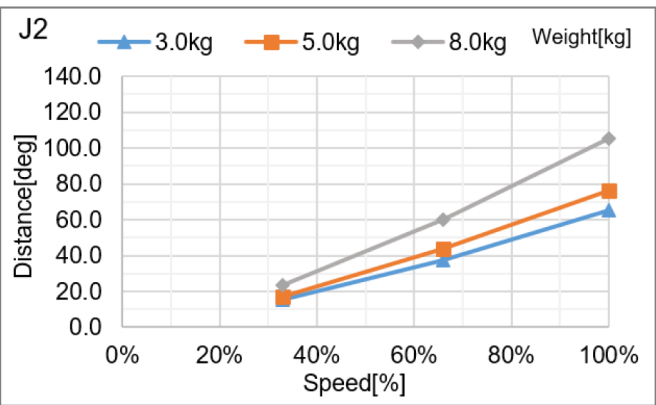
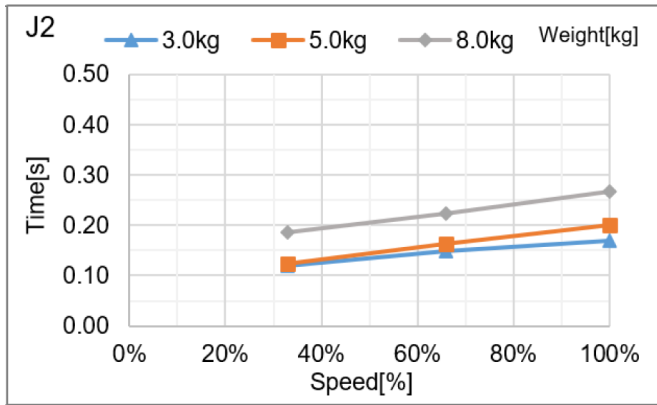

Boost mode

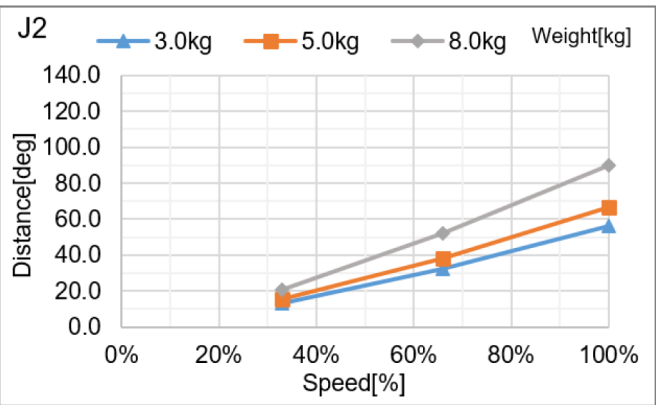
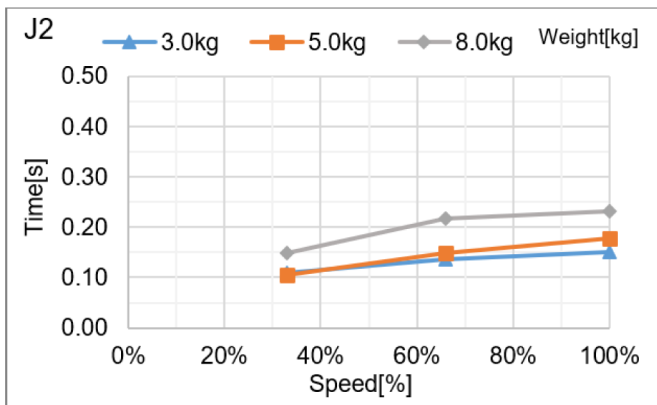

**LS8-C502\*: J3**

Standard mode

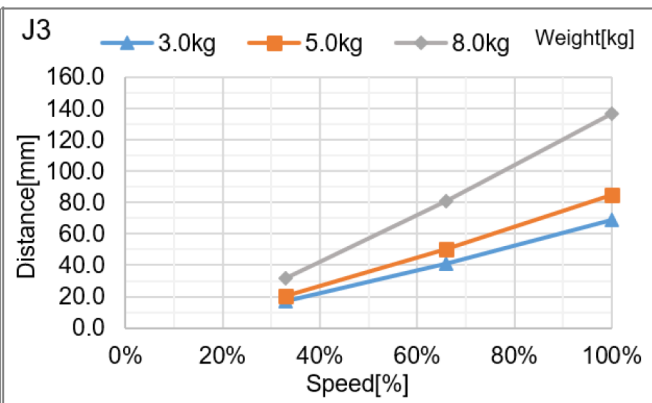
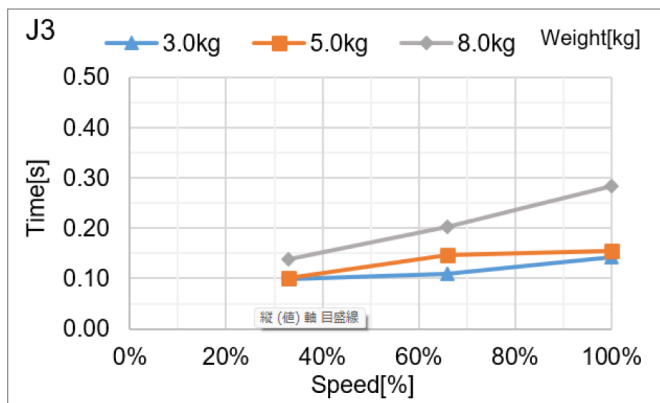

Boost mode

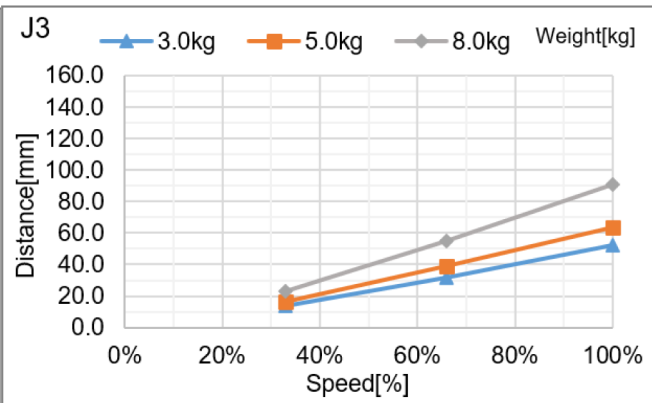
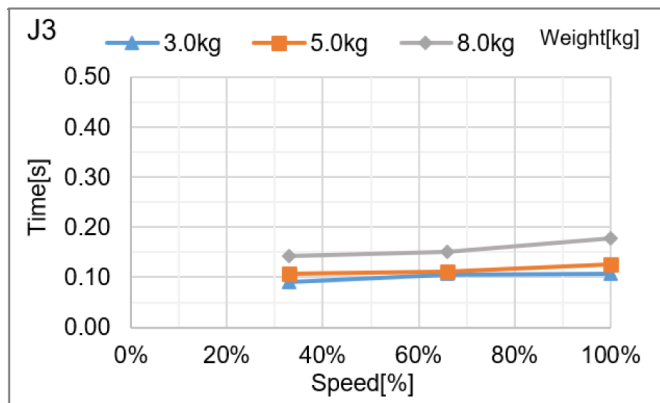

### LS8-C602\*: J1

Standard mode

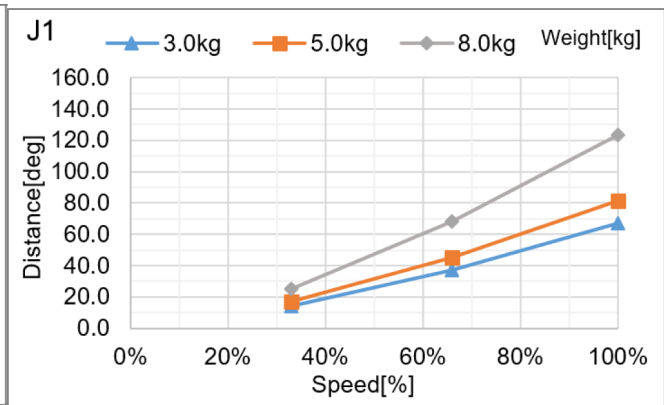
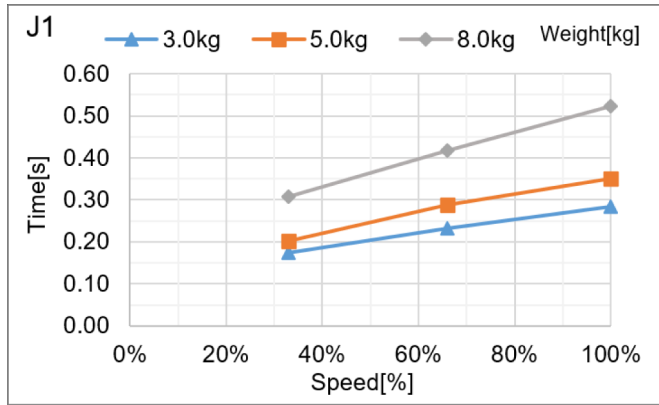

Boost mode

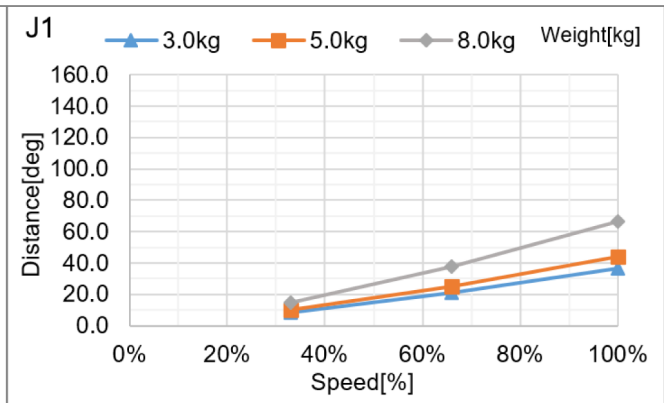
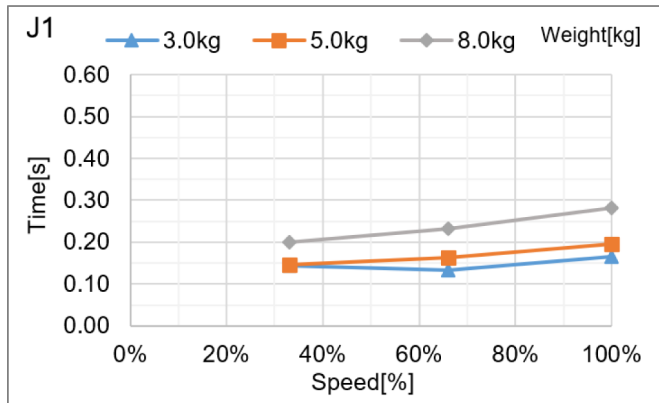

**LS8-C602\*: J2**

Standard mode

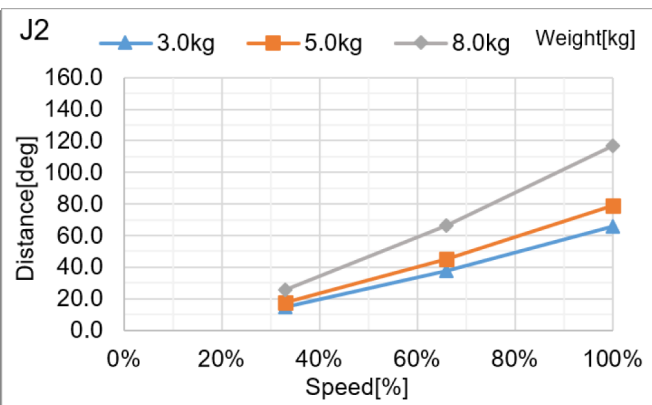
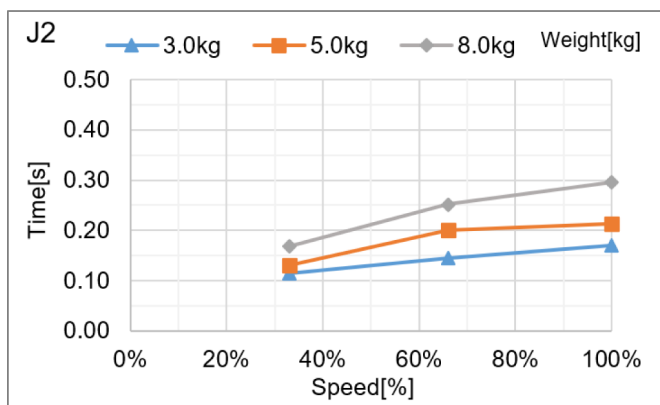

Boost mode

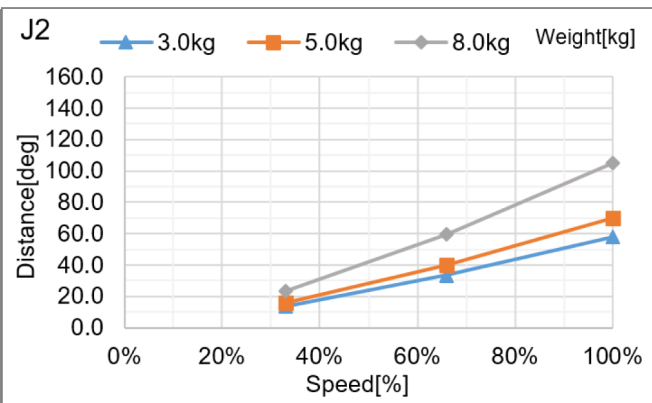
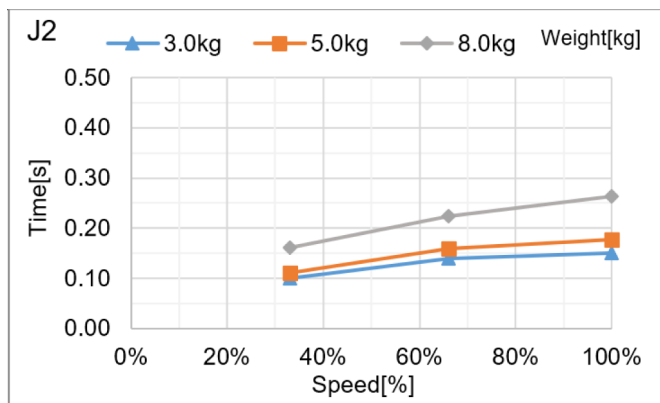

**LS8-C602\*: J3**

Standard mode

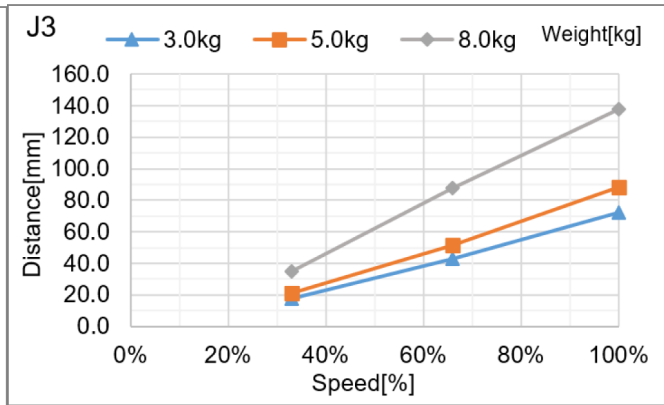
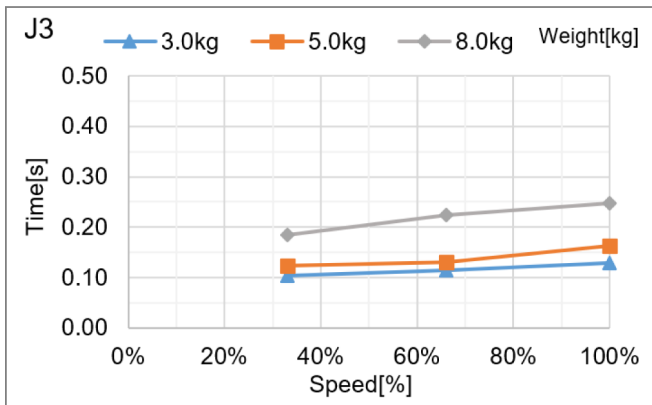

Boost mode

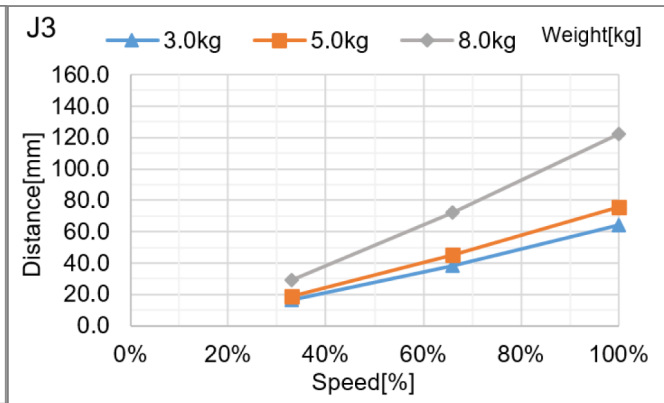
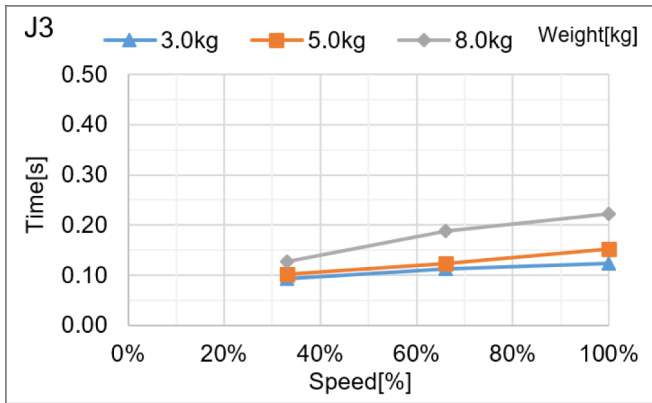

**LS8-C702\*: J1**

Standard mode

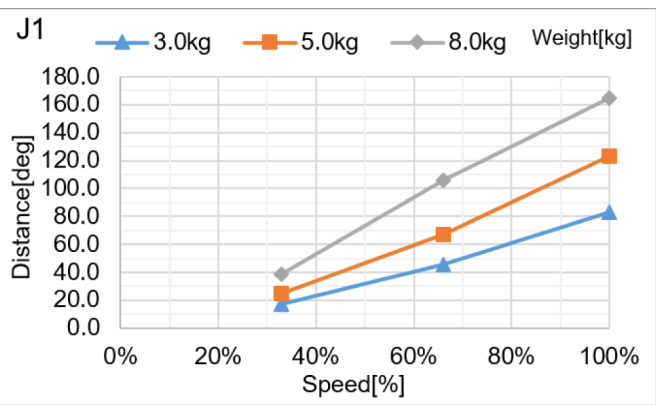
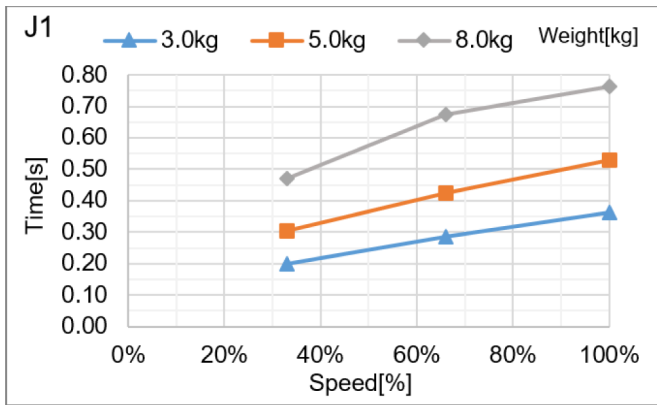

Boost mode

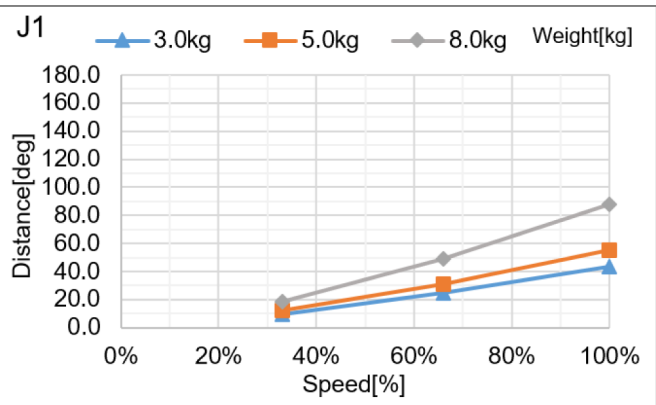
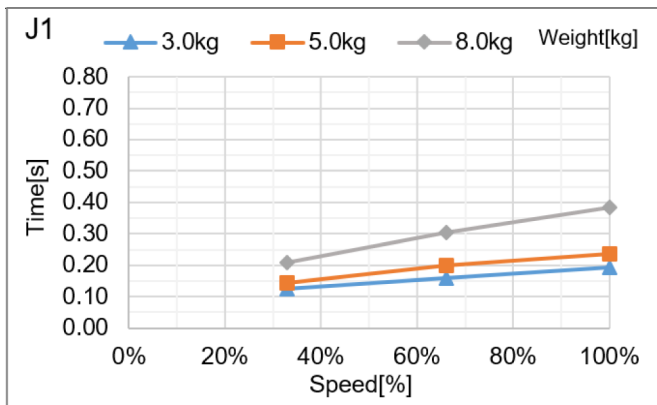

**LS8-C702\*: J2**

Standard mode

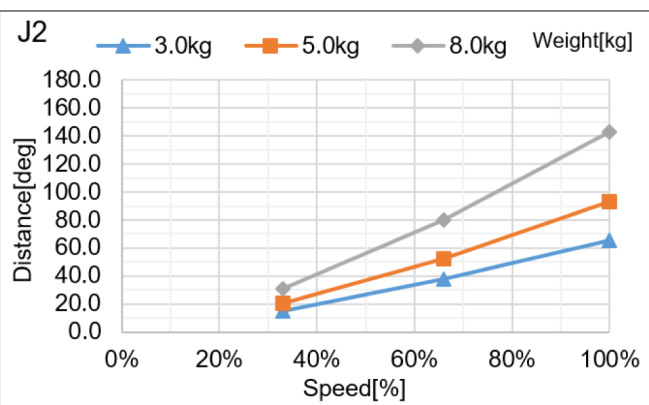
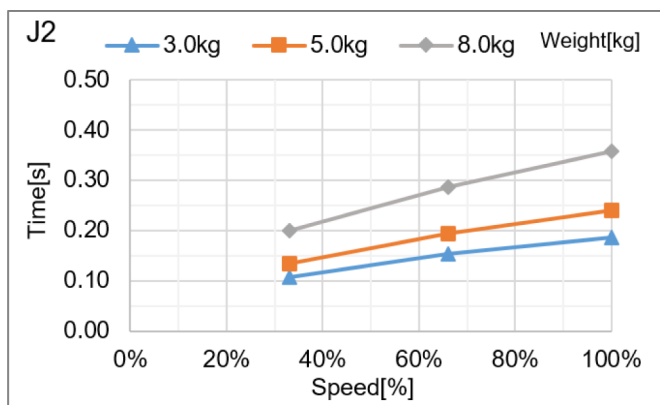

Boost mode

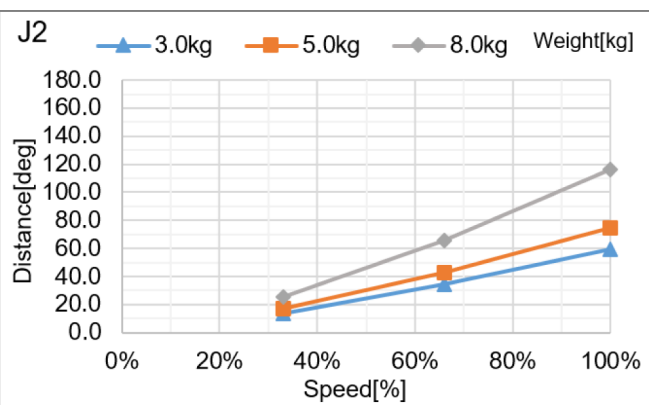
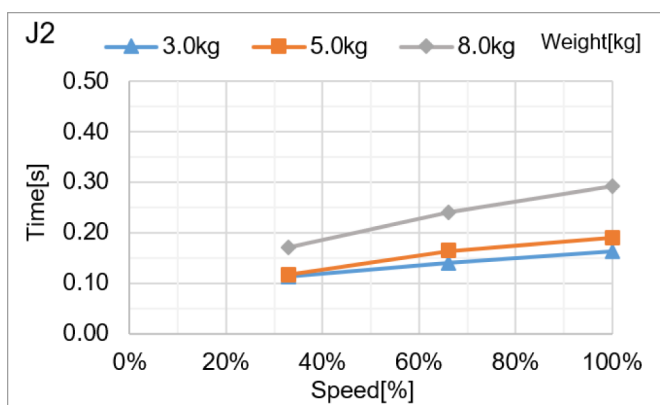

**LS8-C702\*: J3**

Standard mode

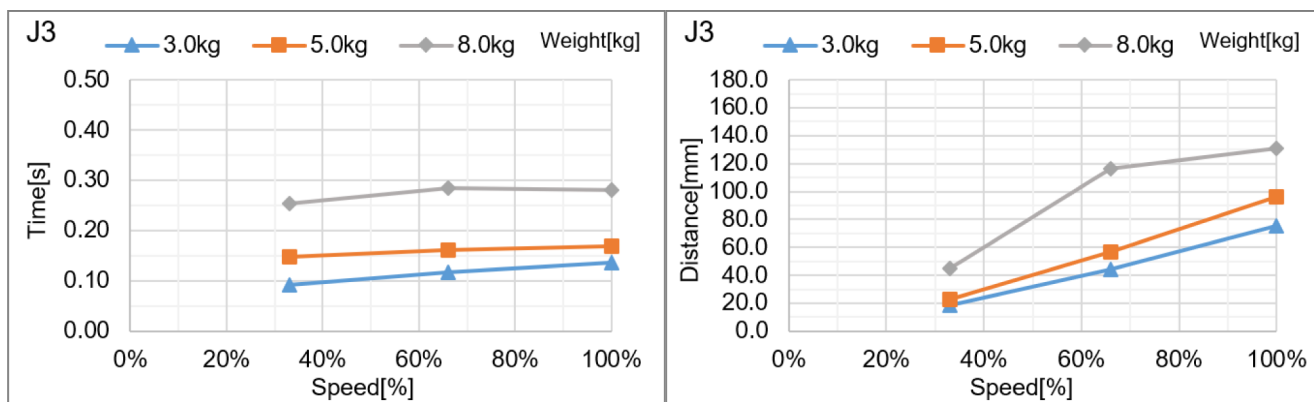

Boost mode

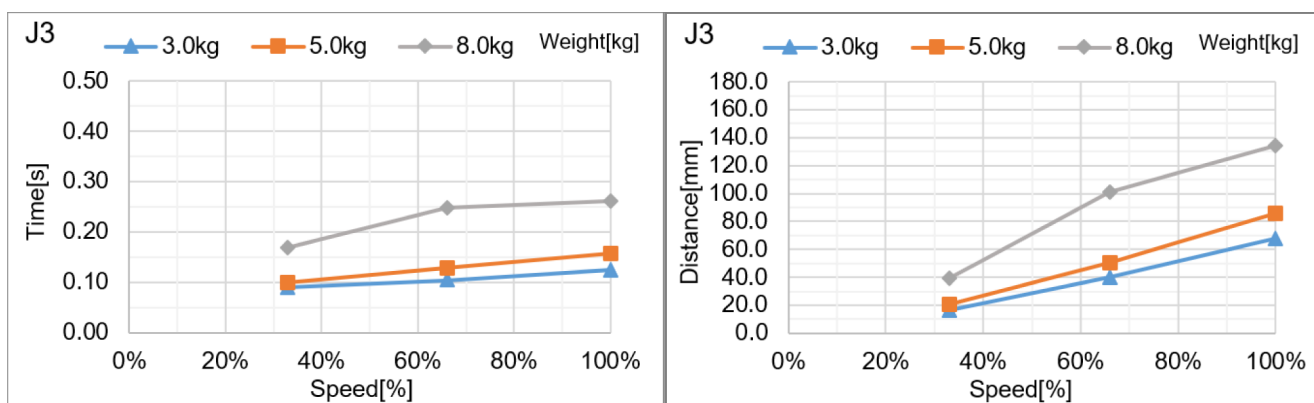

### 6.3.3 LS20-C Stopping Time and Stopping Distance in Emergency

#### LS20-C804\*: J1

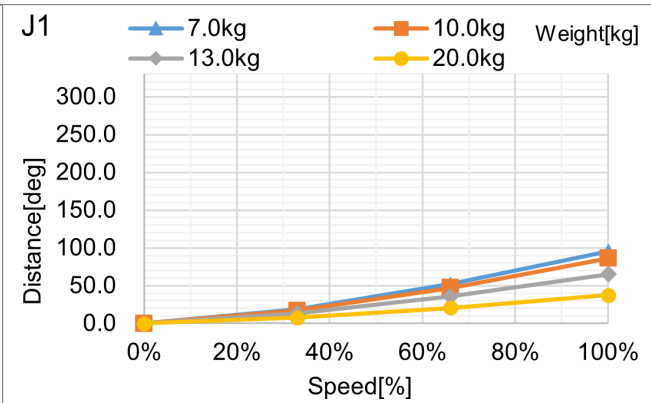
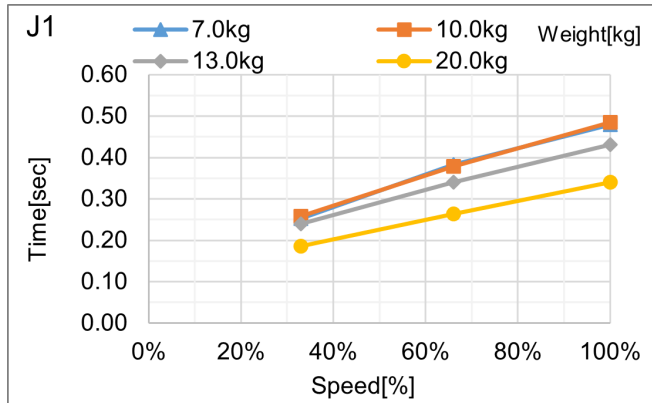

#### LS20-C804\*: J2

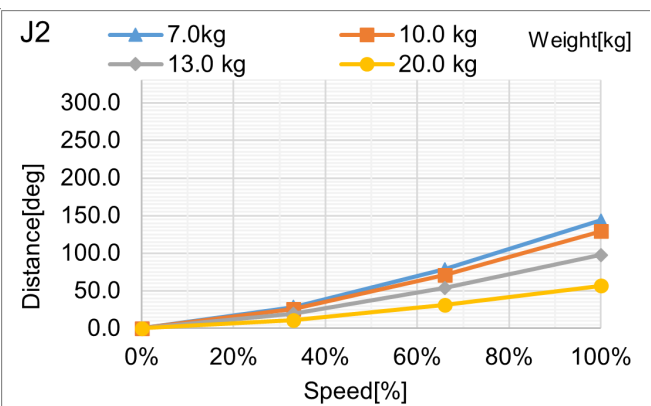
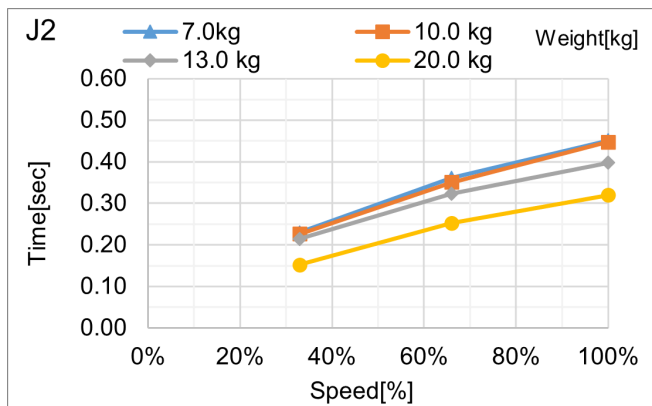

#### LS20-C804\*: J3

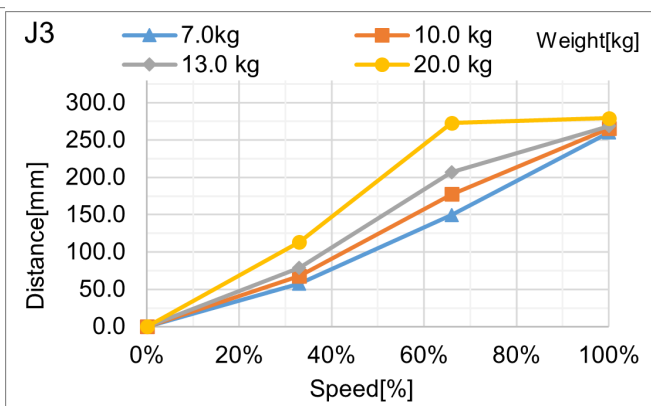
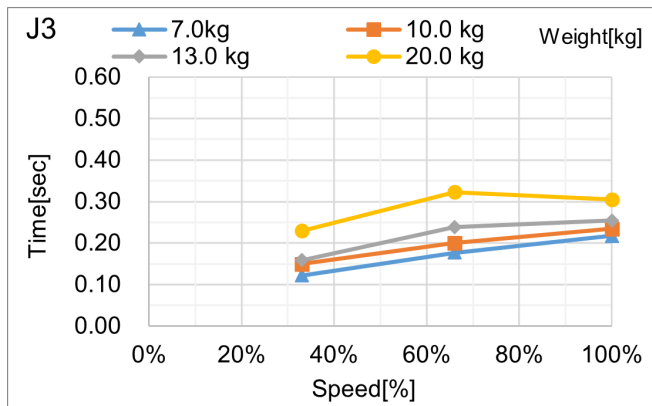

LS20-CA04\*: J1

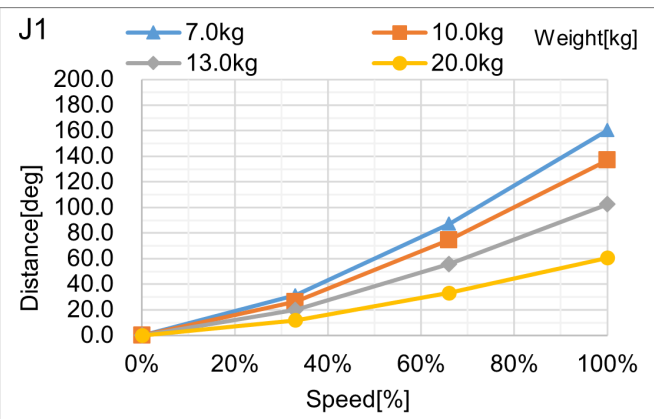
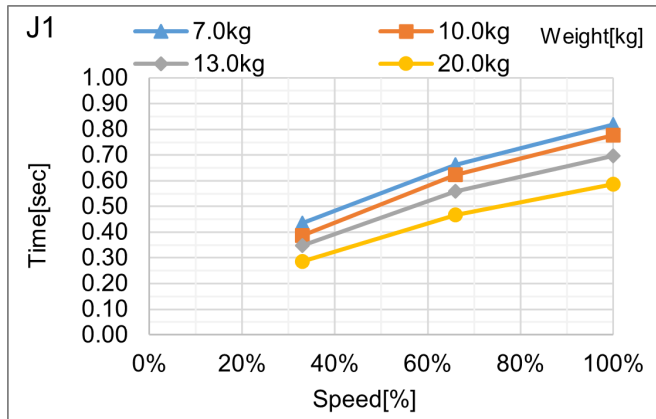

LS20-CA04\*: J2

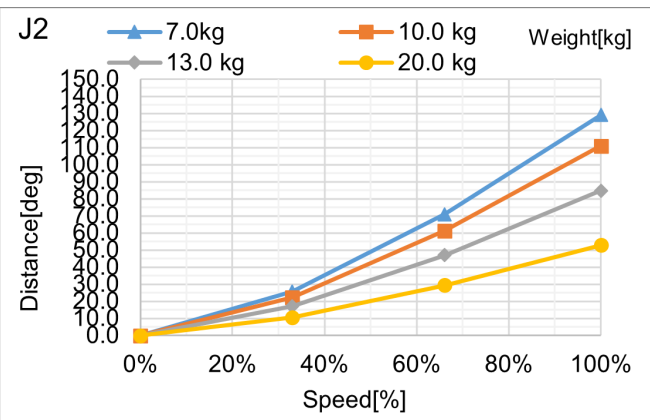
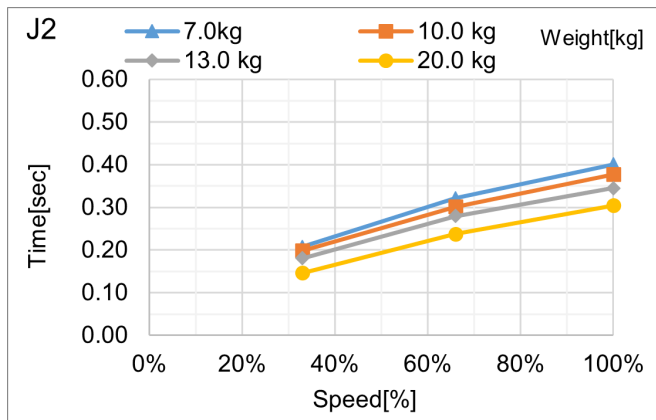

LS20-CA04\*: J3

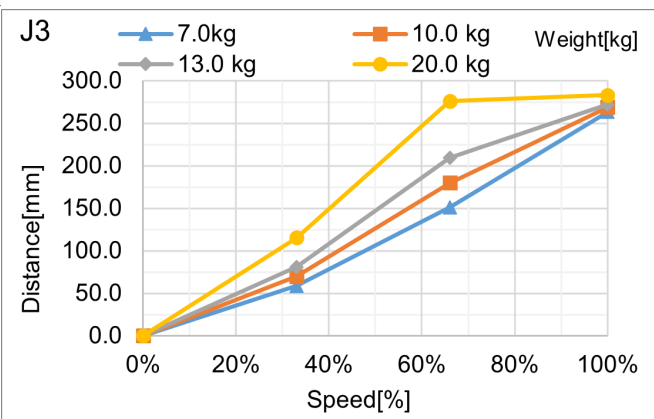
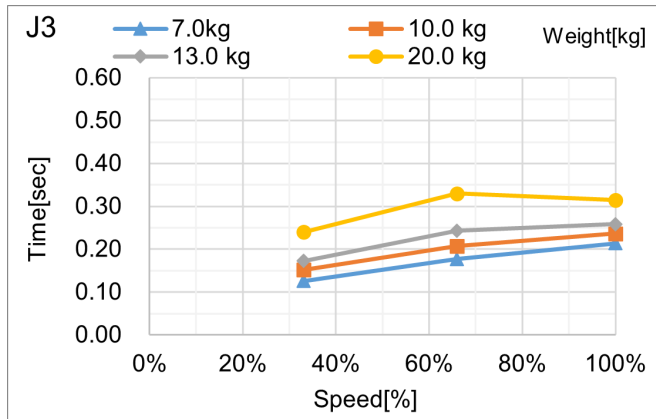

### 6.3.4 LS50-C Stopping Time and Stopping Distance in Emergency

**J1**

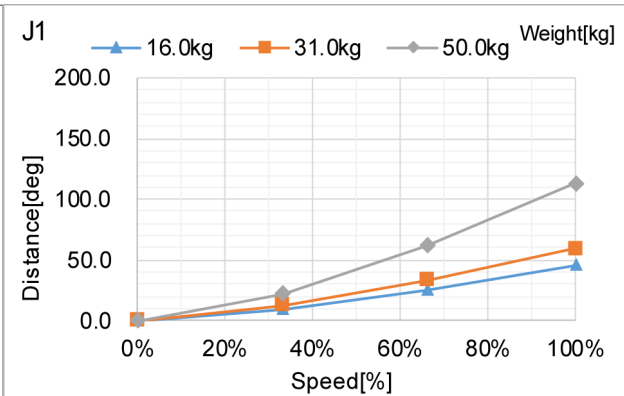
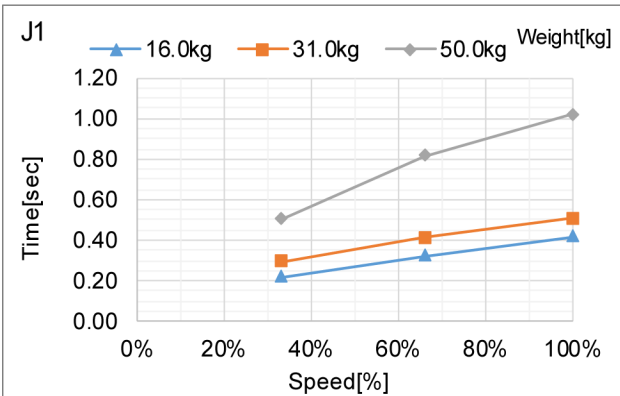

**J2**

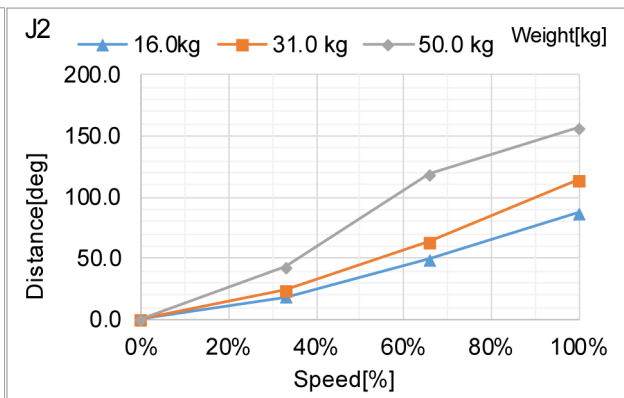
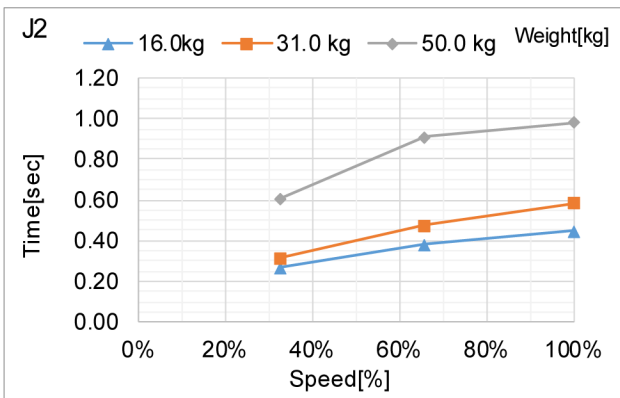

**J3**

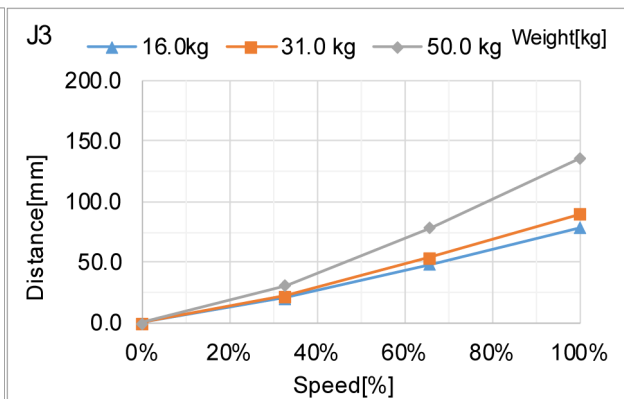
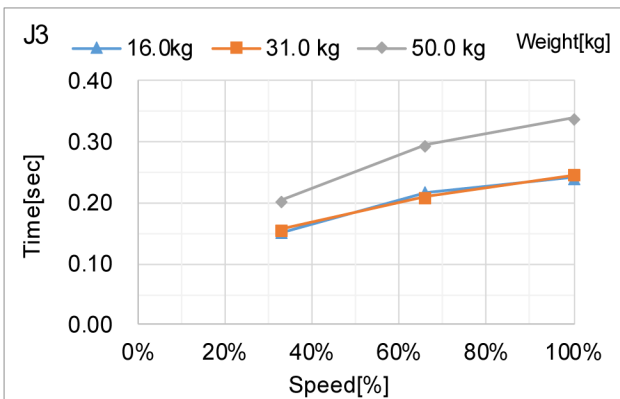

### 6.3.5 Supplementary Information on Stopping time and Stopping distance during an Emergency Stop

The stopping time and stopping distance in Appendix. B were measured using the motion determined by us based on the ISO 10218-1.

Therefore, we cannot guarantee the maximum stopping time and stopping distance in your environment.

The stopping time and stopping distance varies depending on the Manipulator's model, motion, parameter and the timing in which the stop signal was input. Make sure to measure the stopping time and stopping distance according to the customer's environment.

#### KEY POINTS

The following are included in the Manipulator's motion and parameter:

- The start, target and intermediate point of the motion
- Motion command (Go, Move, Jump etc.)
- Weight setting and Inertia setting
- Things that change the motion speed, acceleration, deceleration, and motion timing

For details, refer to the following.

LS4-C, LS8-C:

[Weight and Inertia Settings](#)

LS20-C:

[Weight and Inertia Settings](#)

LS50-C:

[Weight and Inertia Settings](#)

#### 6.3.5.1 How to check the stopping time and stopping distance in the customer's environment

Measure the stopping time and stopping distance of the actual operation with the following method:

1. Create a motion program in the customer's environment.
2. When the motion to check the stopping time and stopping distance starts, input the stop signal on your own timing.
3. Write down the time and distance of when the manipulator stops from the minute the stop signal is input.
4. Repeat 1 through 3 mentioned above and check the maximum stopping time and stopping distance.
  - How to input the stop signal: Manually operate the stop switch or input the stop signal with the Safety PLC.
  - How to measure the stopping position: Use a measure. You can also measure the angle with the Where or RealPos command.
  - How to measure the stopping time: Use a stop watch. You can also measure with the Tmr function.

#### CAUTION

The stopping time and stopping distance varies depending on the timing that the stop signal was input.

Perform a risk assessment based on the maximum stopping time and stopping distance and design the device to prevent interfering with people and objects.

Therefore, make sure to always change the timing you input the stop signal and continue measuring to get the maximum value.

To shorten the stopping time and stopping distance, use the safety limited speed and limit the maximum speed. For details on the safety limited speed (SLS), refer to the following manual:

“Safety Function Manual”

### 6.3.5.2 Introduction of commands that are useful in measuring the stopping time and stopping distance

Commands	Functions
Where	Displays the data of the robot's current position.
RealPos	Returns the specified robot's current position. Unlike the CurPos's motion target position, it receives the robot's position from the encoder.
PAgl	Returns by calculating the Joint's position from the specified coordinate value. P1 = RealPos 'Gets the current position. Joint1 = PAgl (P1, 1) ' Call for J1's angle from the current position
SF_RealSpeedS	Displays the current speed from the Safety Limited Speed in mm/s.
Tmr	The Tmr function returns the time, in seconds, since the timer starts.
Xqt	Runs the program specified by the function name and creates a task. Run the functions used to measure the stopping time and stopping distance with the task that was setup by installing the NoEmgAbort option. Run tasks that does not stop even with the emergency stop or when the safeguard is open.

For details, refer to the following manual.

“Epson RC+ SPEL+ Language Reference”

## 6.4 Appendix D: Stopping time and Stopping distance when Safeguard is Opened

The stopping time and stopping distance when safeguard is opened are shown in a graph for each model.

The stopping time is “Stopping time” in the figure below. Be sure to confirm that safety is ensured according to the installation environment and operation of the robot.

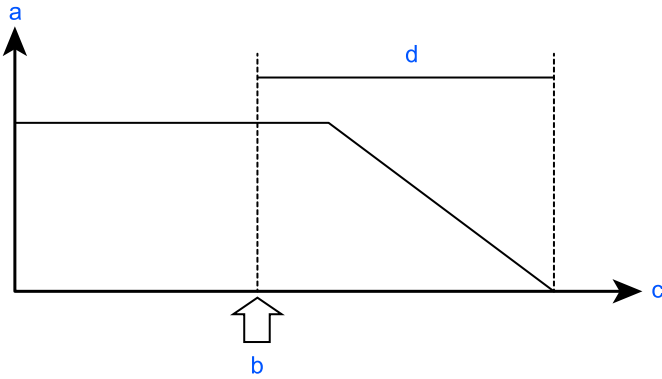

Symbol	Description
a	Motor speed
b	Safeguard open
c	Time
d	Stopping Time

### Conditions

The stopping time and stopping distance vary depending on the parameters (setting value) set for the robot. These graphs show the time and distance for the following parameters.

These conditions are made based on the ISO 10218-1:2011 Annex B.

- Accel : 100, 100
- Speed: 100 %, 66 %, 33 % Setting
- Weight: 100 %, 66 %, 33 % of the maximum payload, rated payload
- Arm elongation rate: 100 %, 66 %, 33 % \*1
- Other: Default
- Motion: Singular axis motion of the Go command
- Input timing of the Stop signal: Input with maximum speed. In this motion, it is the center of the motion range.

\*1 The arm elongation rate when J1 is operating: Arm elongation rate 0 is as shown in the figure below.

Among the following arm elongation rate, the stopping time and stopping distance with the longest results are indicated in the graph.

During J2 operation, J3 is 0 mm.

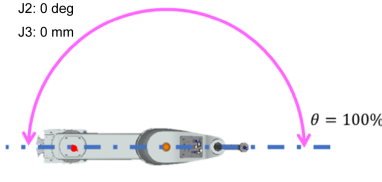
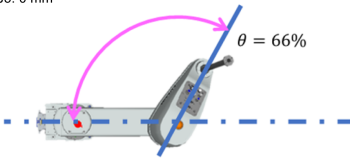
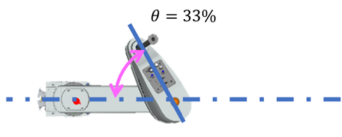
Axis	$\theta = 100\%$	$\theta = 66\%$	$\theta = 33\%$
J1	<p>J2: 0 deg J3: 0 mm</p>  <p><math>\theta = 100\%</math></p>	<p>J2: 60 deg J3: 0 mm</p>  <p><math>\theta = 66\%</math></p>	<p>J2: 120 deg J3: 0 mm</p>  <p><math>\theta = 33\%</math></p>

### Description of legend

The graph is shown for each Weight value (rated payload, 100%, about 66%, and about 33% of the maximum payload).

- Horizontal axis: Arm speed (Speed value)
- Vertical axis: Stopping time and stopping distance in each arm speed
- Time [sec]: Stopping time (sec)
- Distance [deg]: J1 and J2 stopping distance (degree)
- Distance [mm]: Stopping distance of J3

The following apply to malfunction of a singular product.

- Stopping distance and angle: Reach the mechanical stop of each axis
- Stopping Time: Add 500 ms

## 6.4.1 LS4-C Stopping Time and Stopping Distance when Safeguard is Opened

### LS4-C401\*: J1

Standard mode

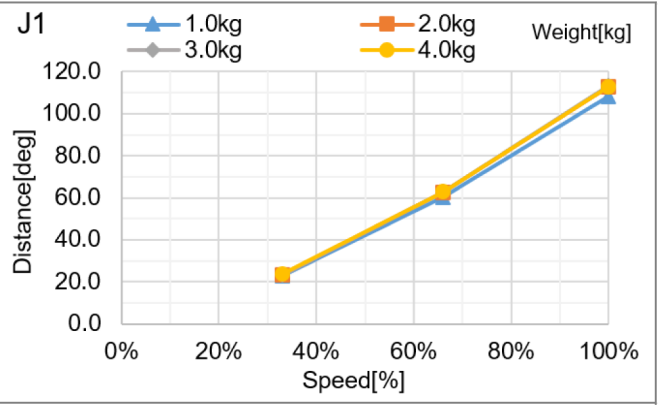
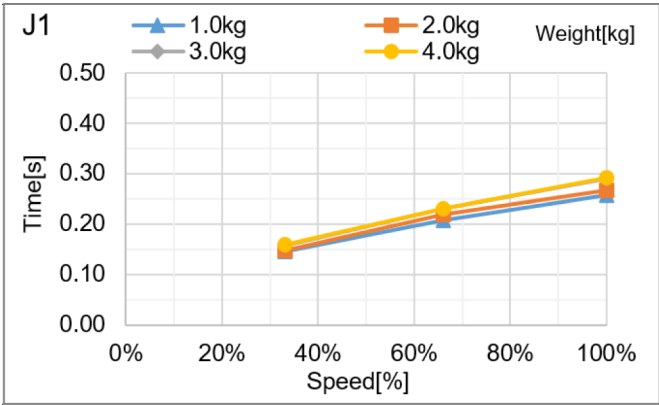

Boost mode

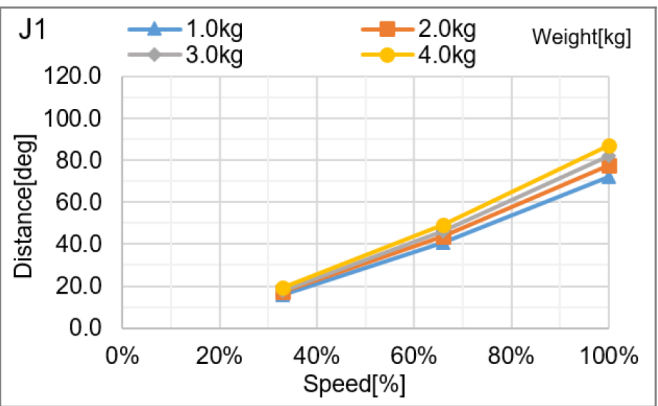
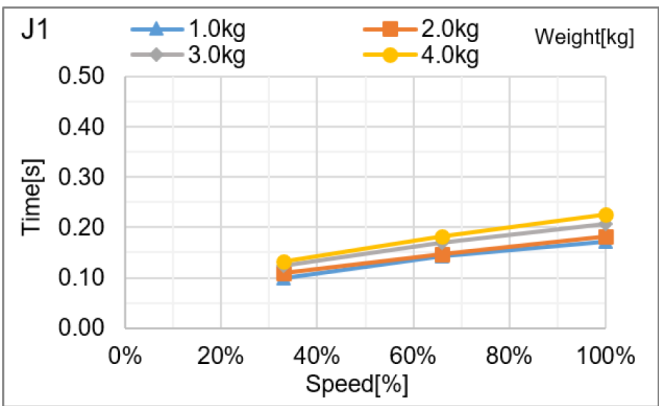

**LS4-C401\*: J2**

Standard mode

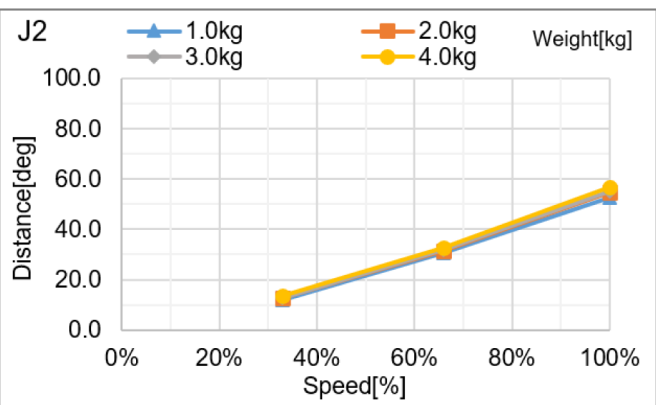
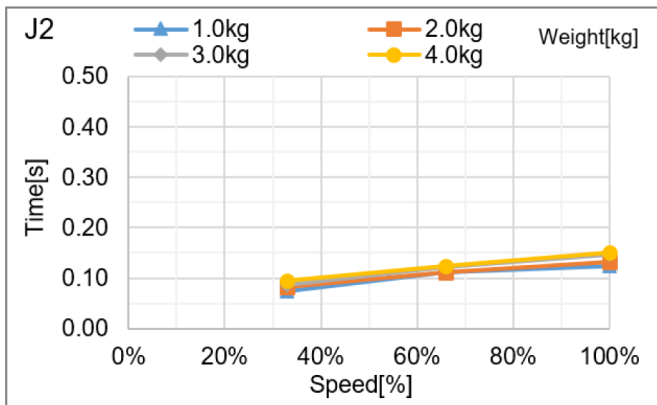

Boost mode

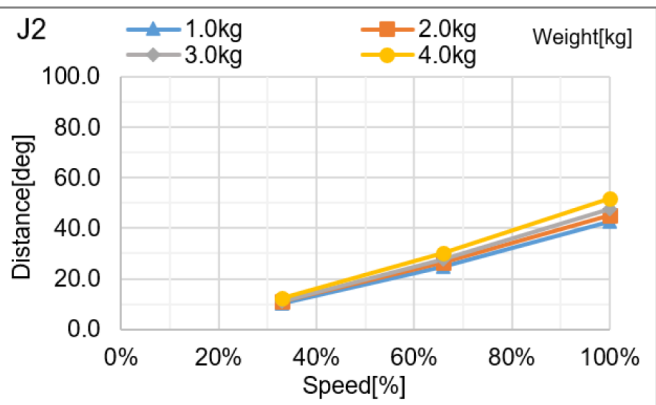
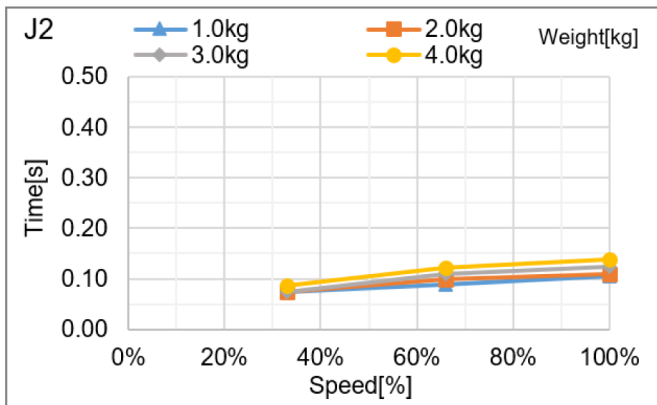

**LS4-C401\*: J3**

Standard mode

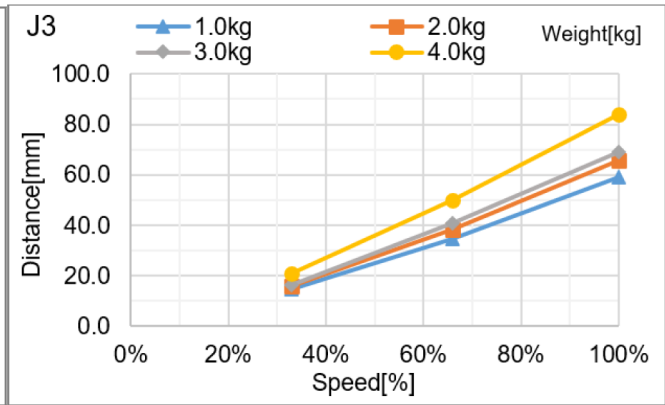
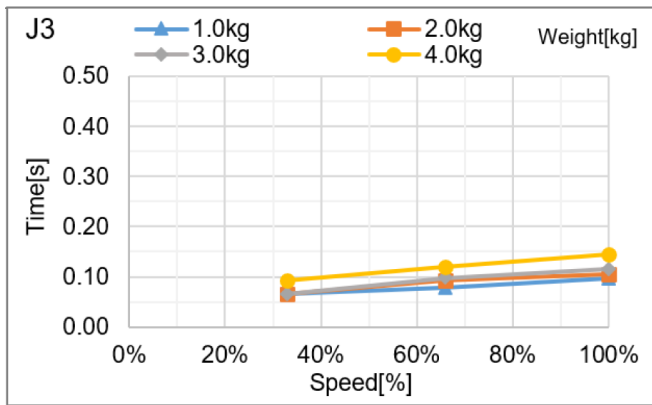

Boost mode

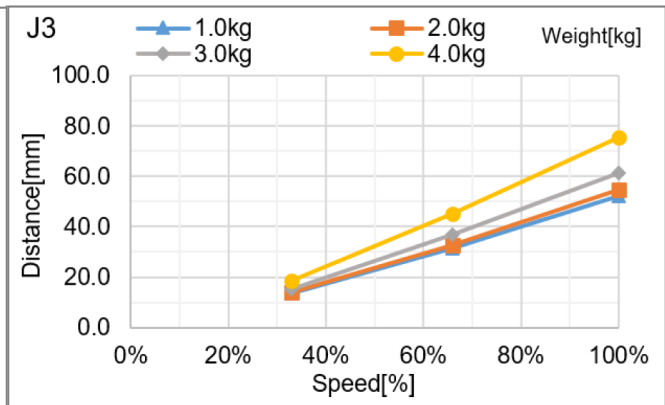
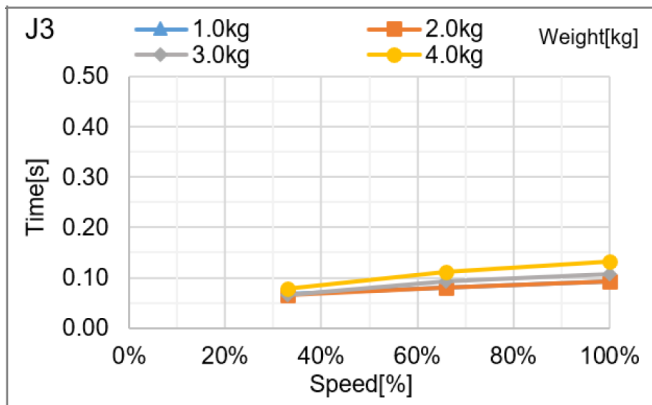

## 6.4.2 LS8-C Stopping Time and Stopping Distance when Safeguard is Opened

### LS8-C502\*: J1

Standard mode

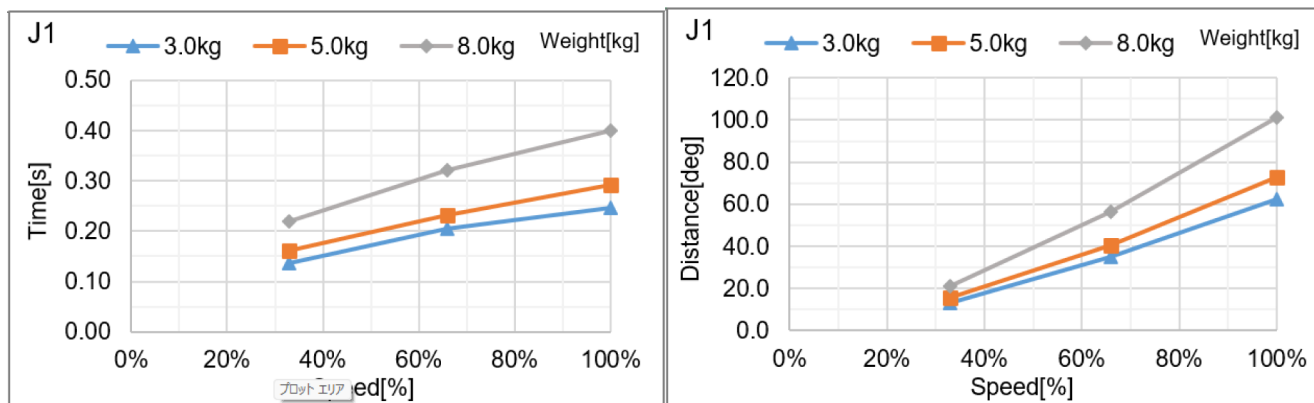

Boost mode

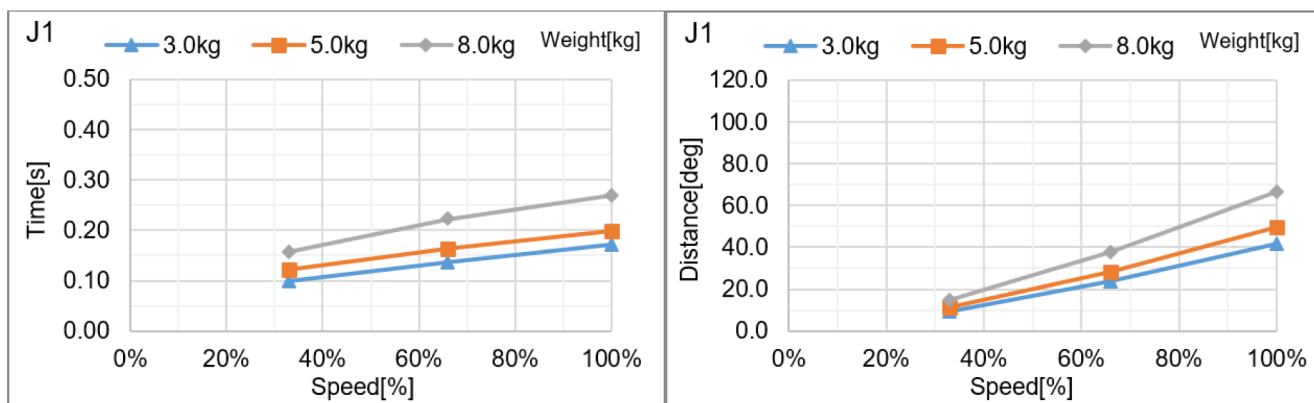

**LS8-C502\*: J2**

Standard mode

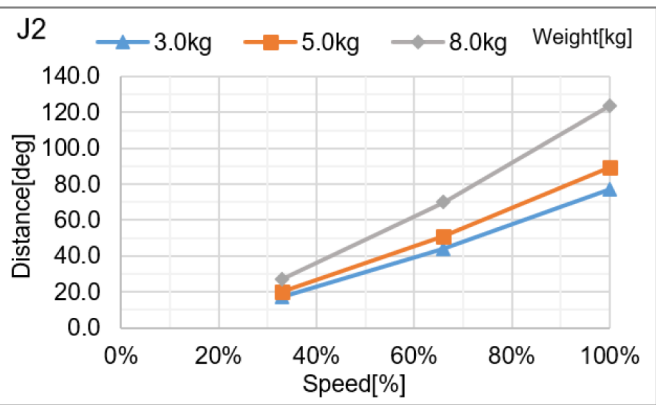
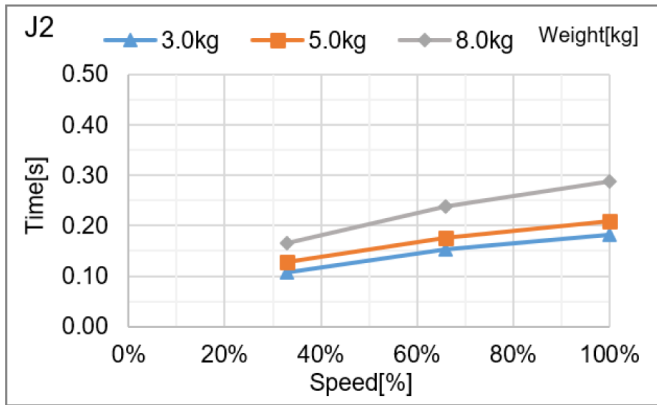

Boost mode

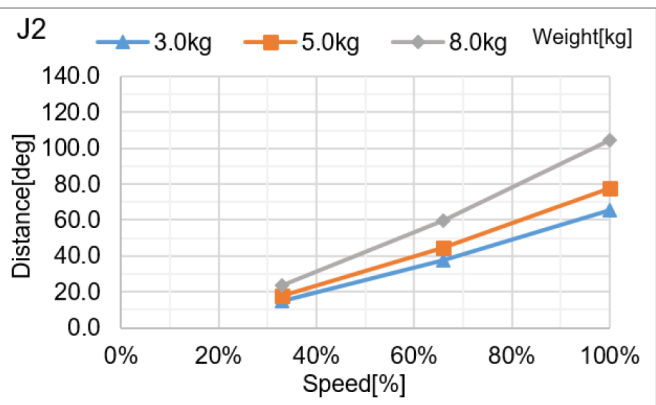
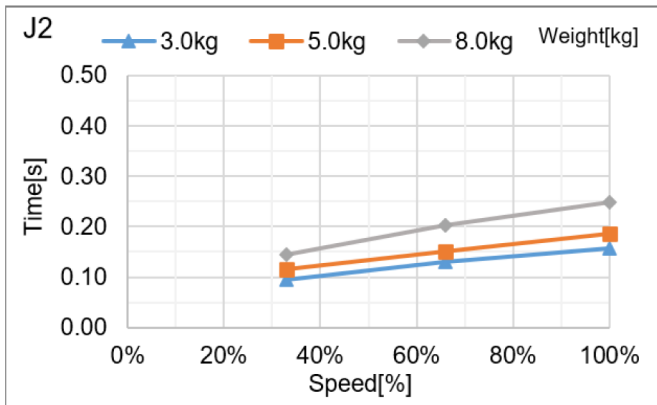

**LS8-C502\*: J3**

Standard mode

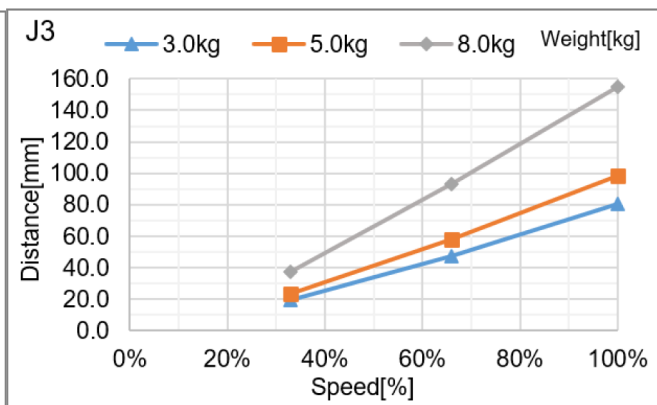
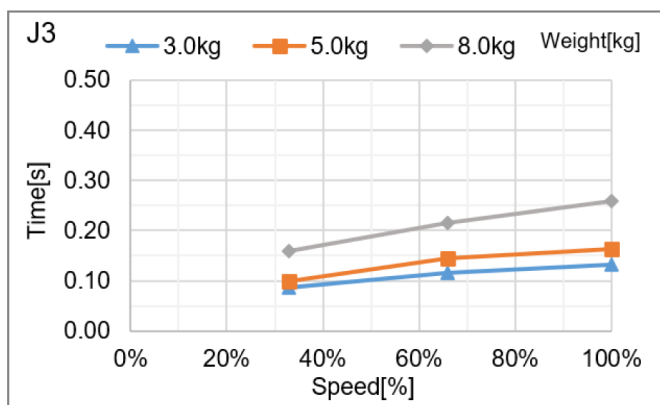

Boost mode

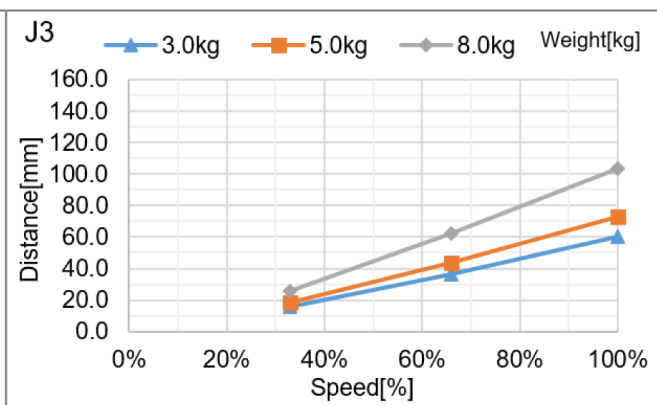
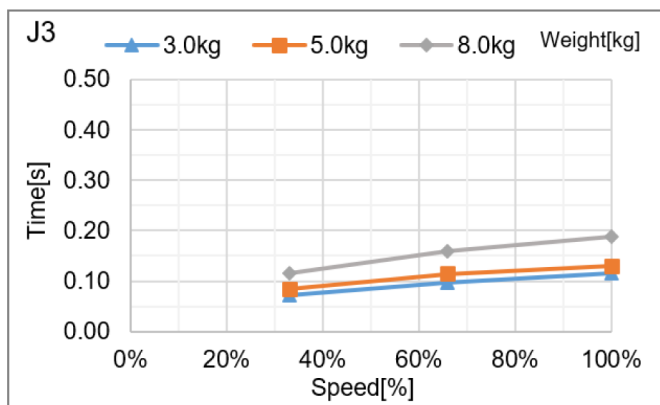

**LS8-C602\*: J1**

Standard mode

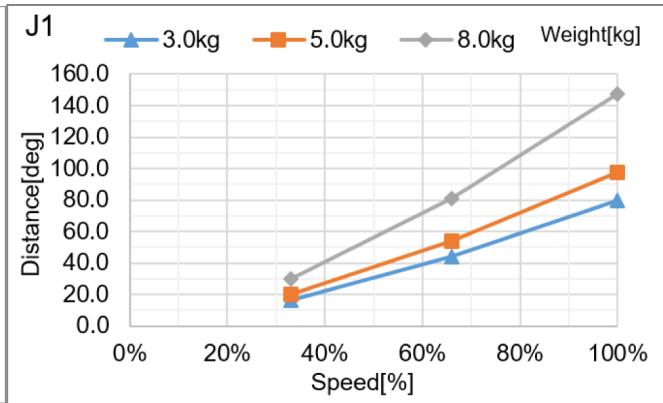
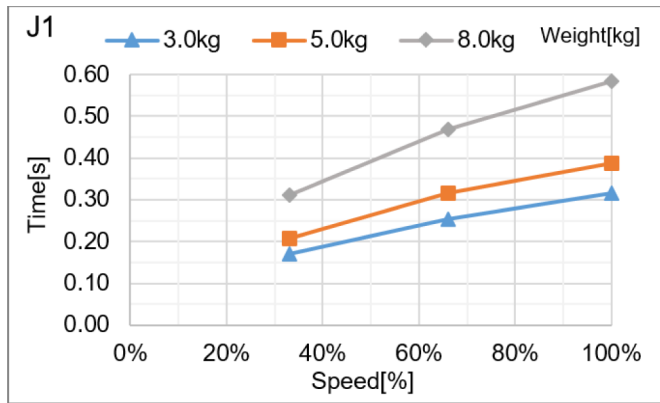

Boost mode

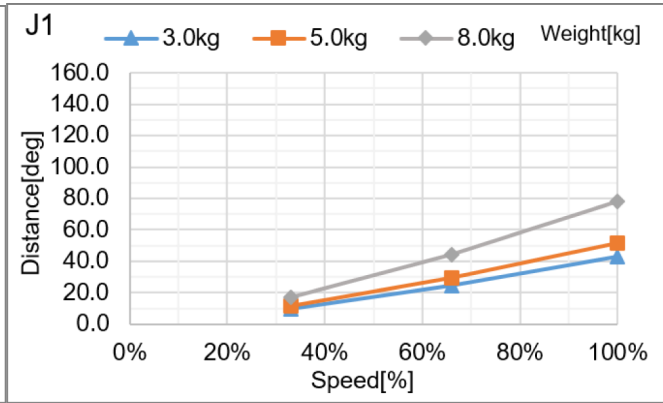
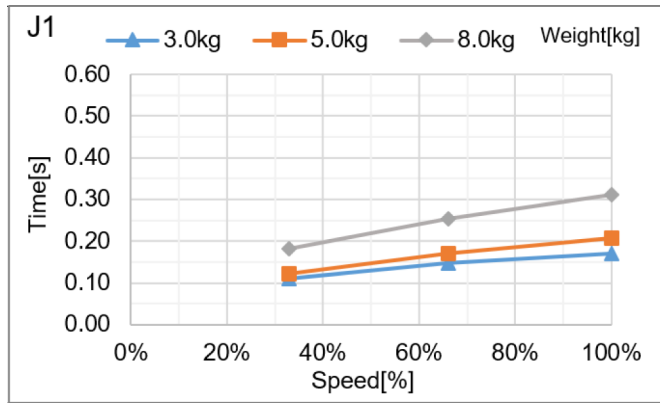

**LS8-C602\*: J2**

Standard mode

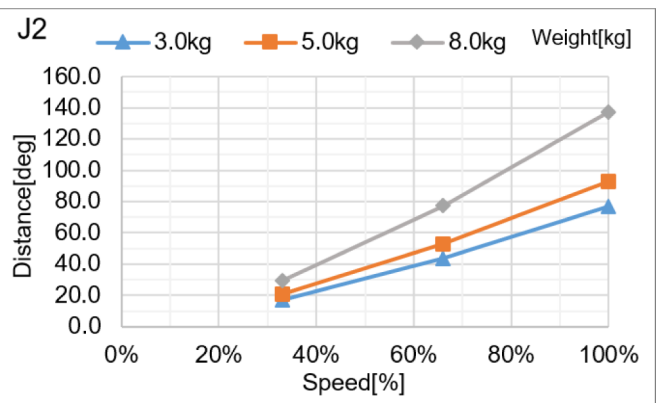
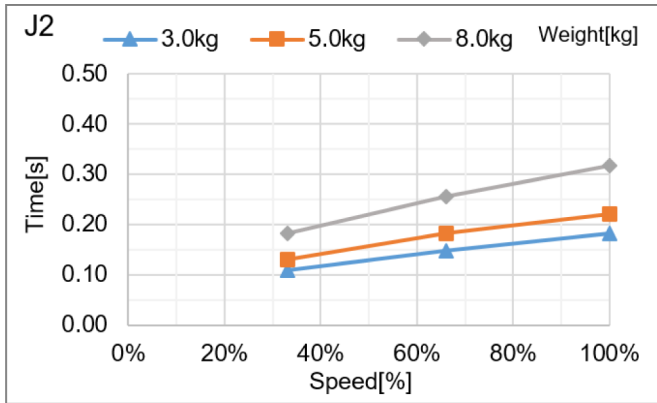

Boost mode

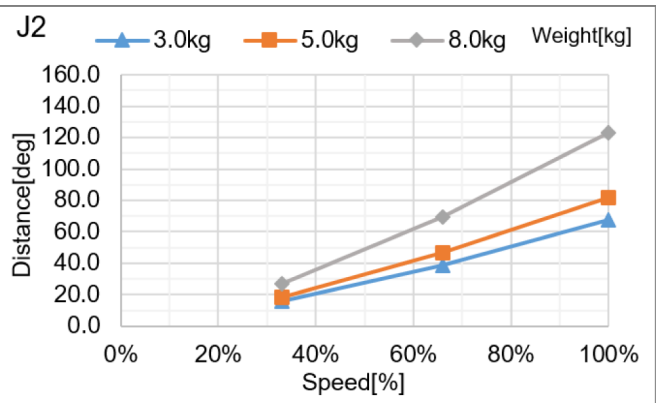
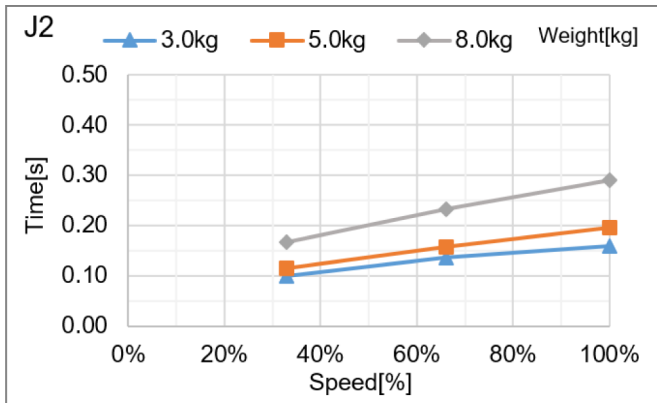

### LS8-C602\*: J3

Standard mode

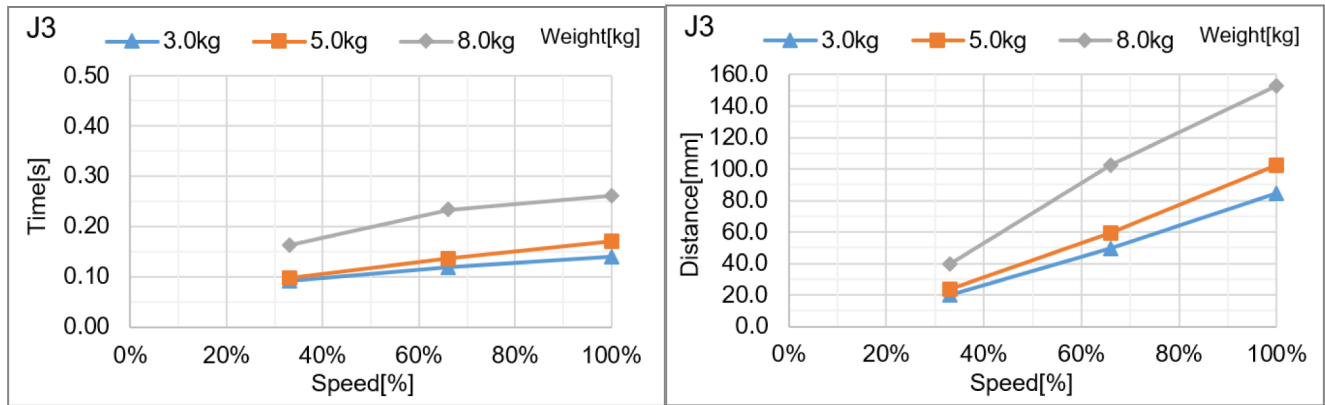

Boost mode

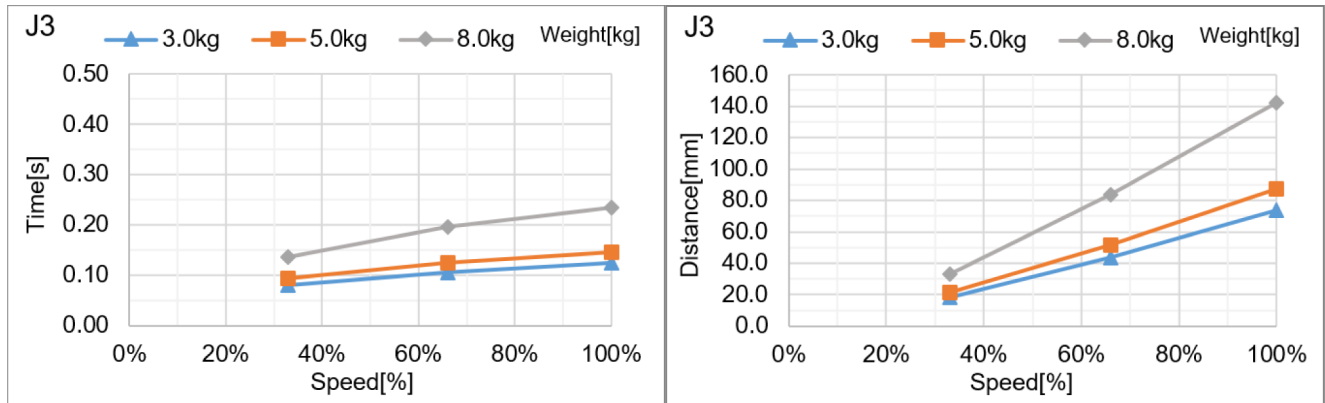

**LS8-C702\*: J1**

Standard mode

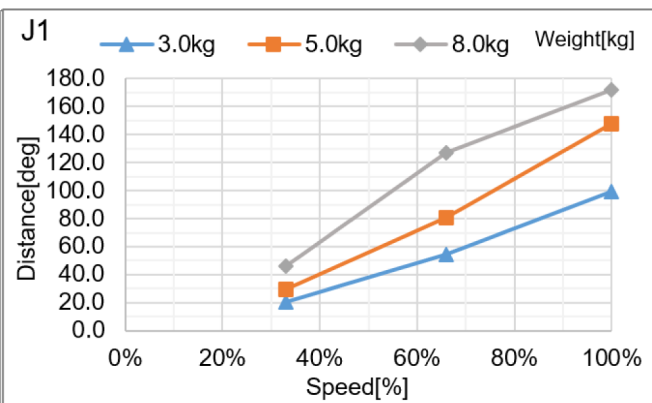
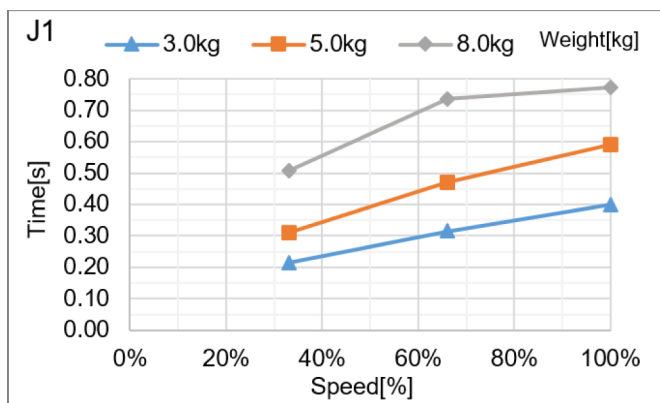

Boost mode

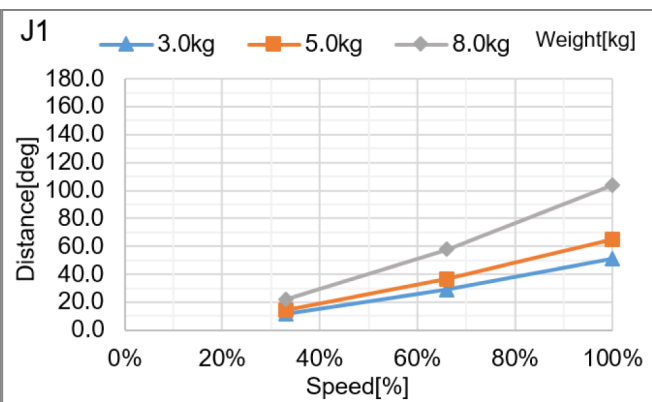
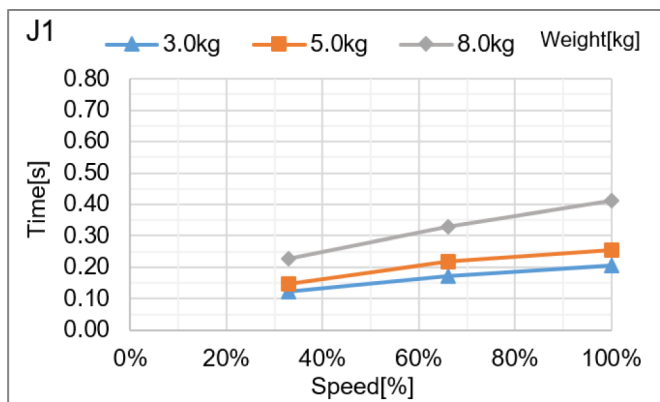

**LS8-C702\*: J2**

Standard mode

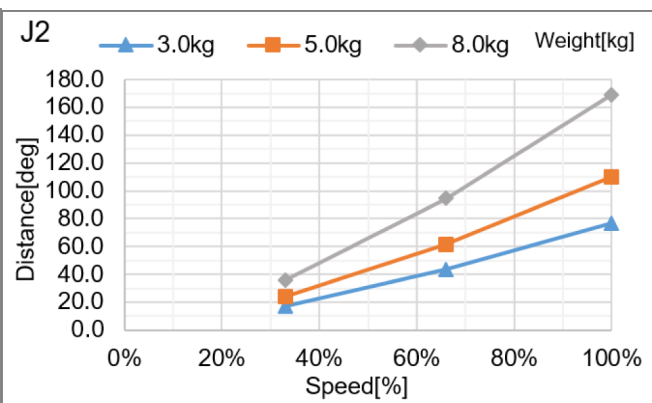
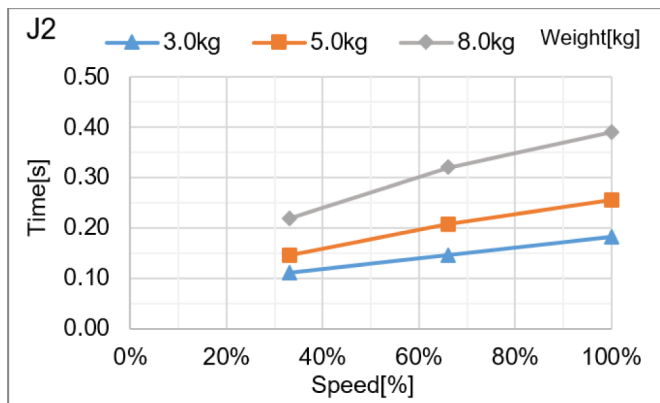

Boost mode

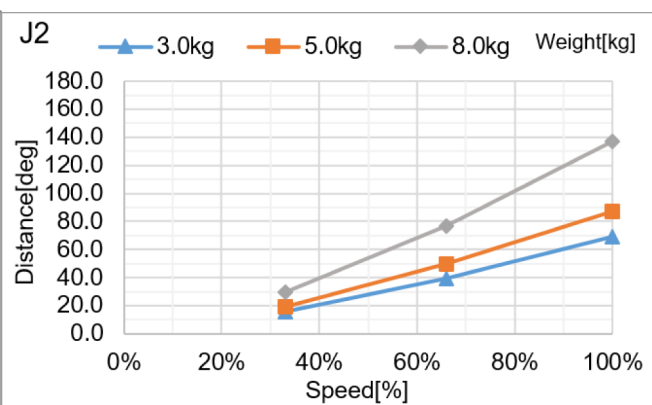
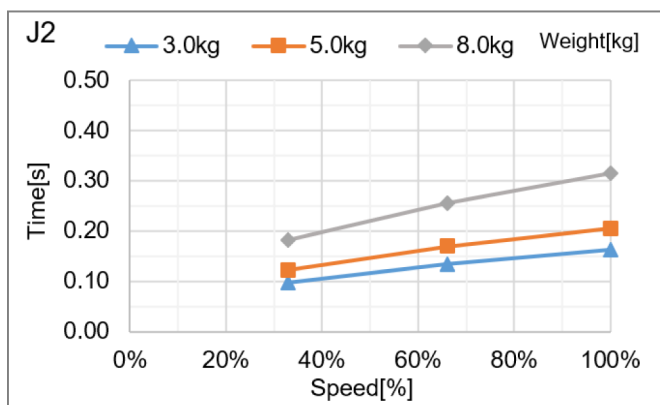

**LS8-C702\*: J3**

Standard mode

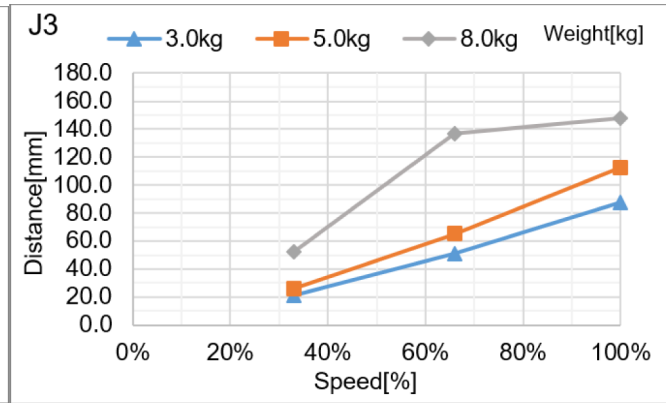
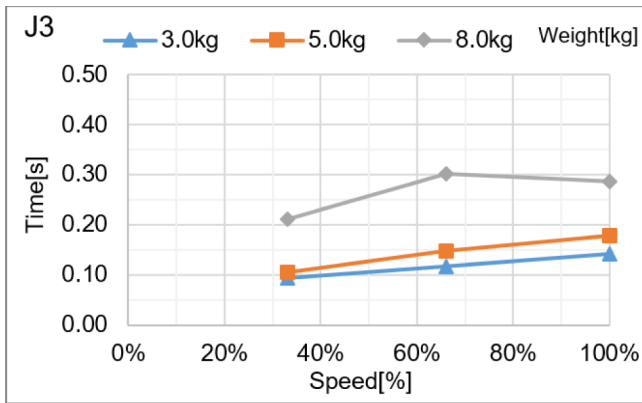

Boost mode

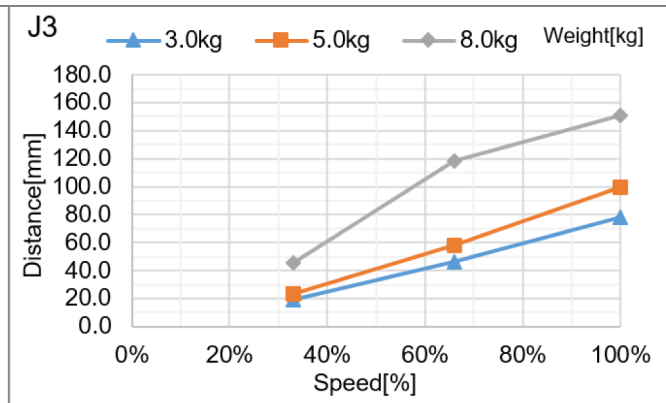
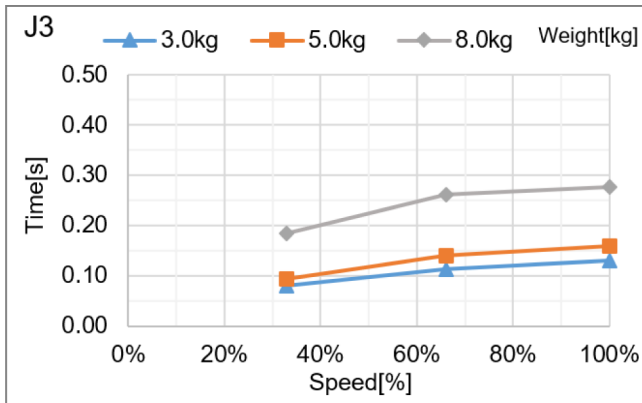

### 6.4.3 Stopping Time and Stopping Distance when Safeguard is Opened

#### LS20-C804\*: J1

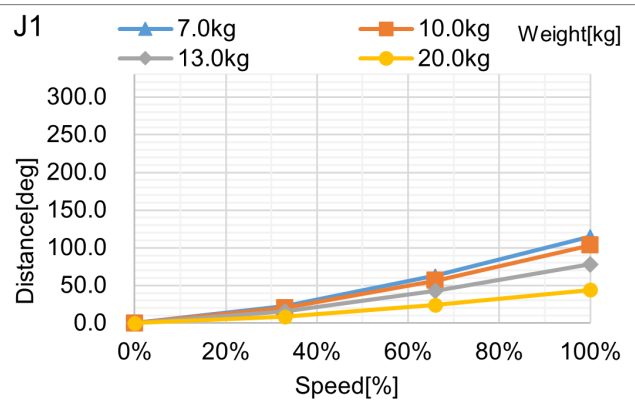
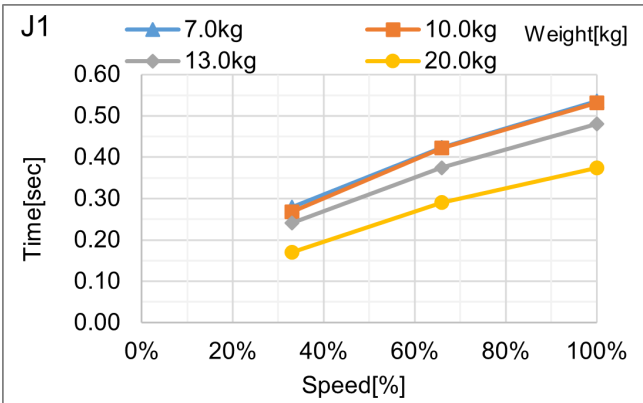

#### LS20-C804\*: J2

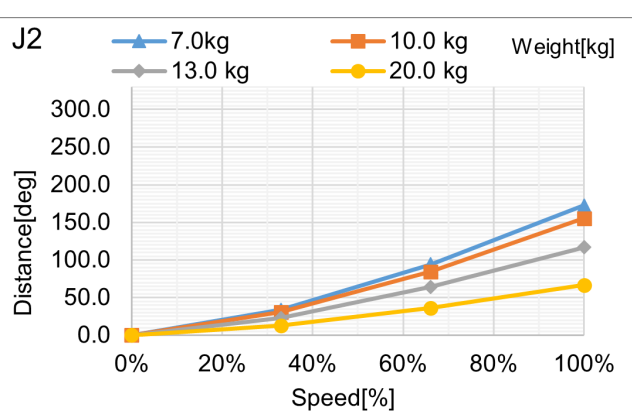
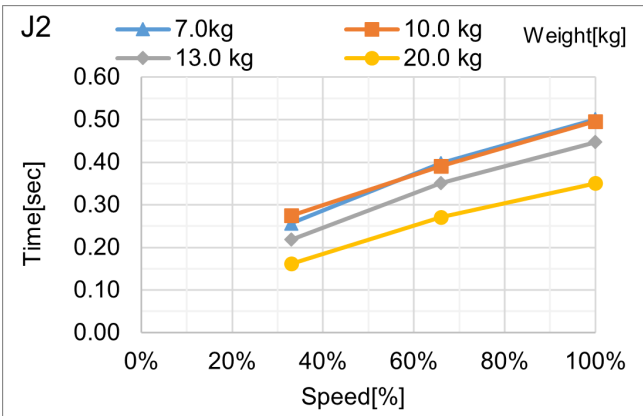

#### LS20-C804\*: J3

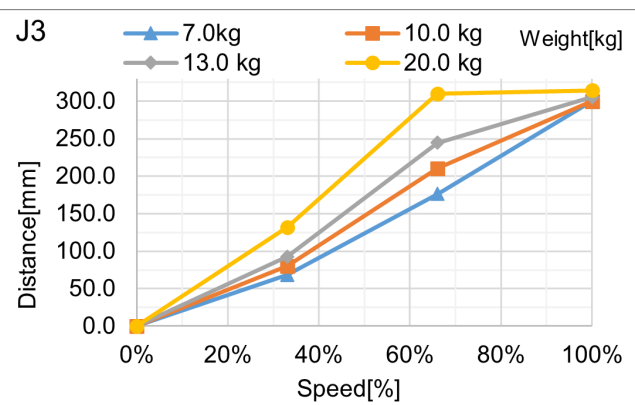
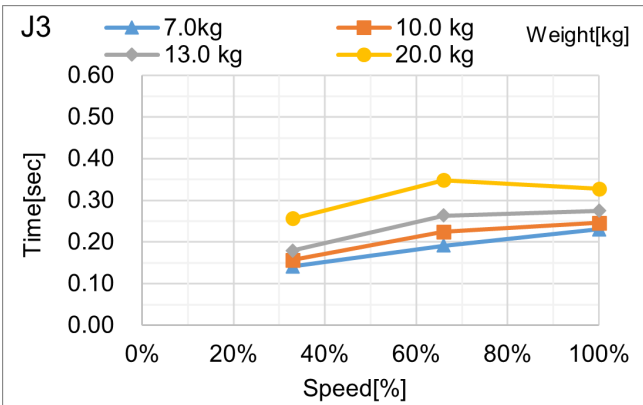

**LS20-CA04\*: J1**

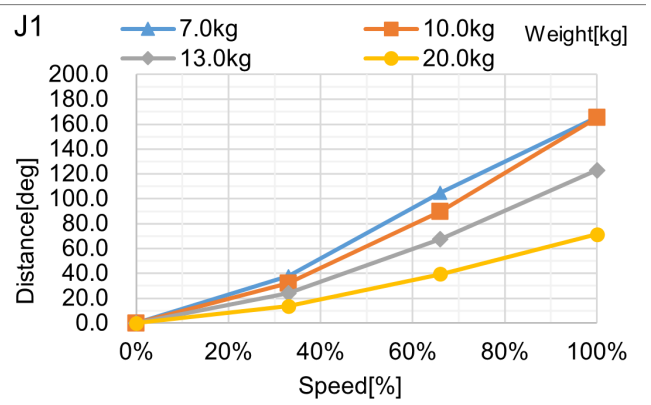
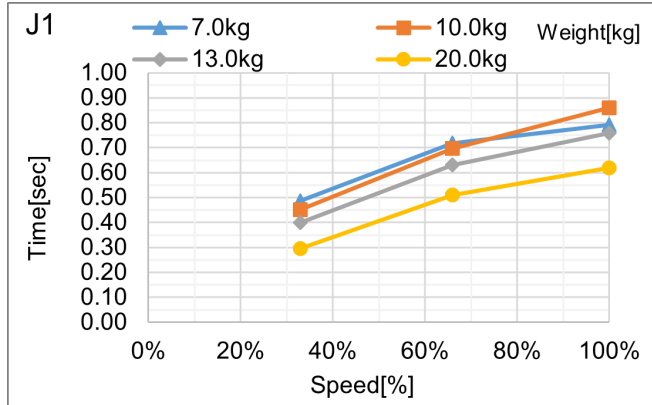

**LS20-CA04\*: J2**

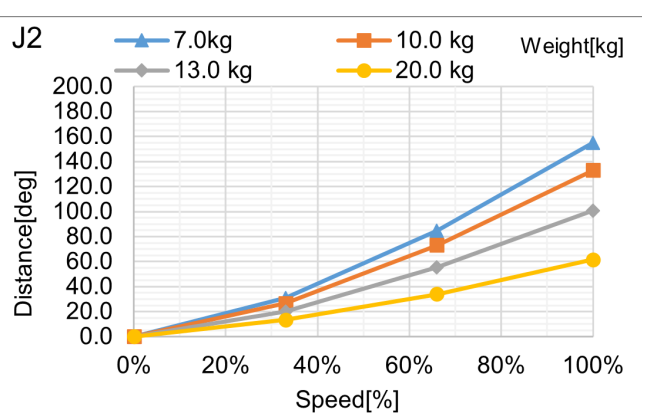
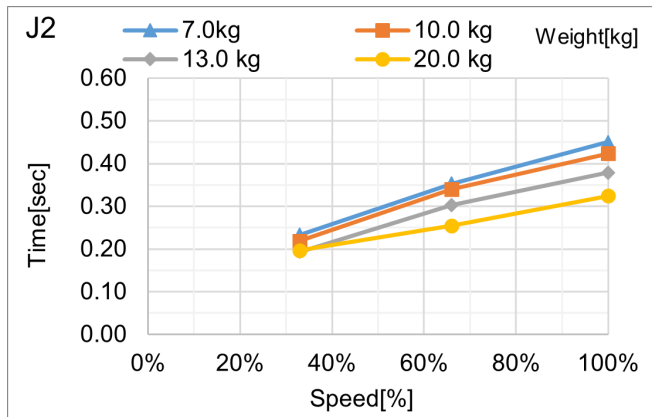

**LS20-CA04\*: J3**

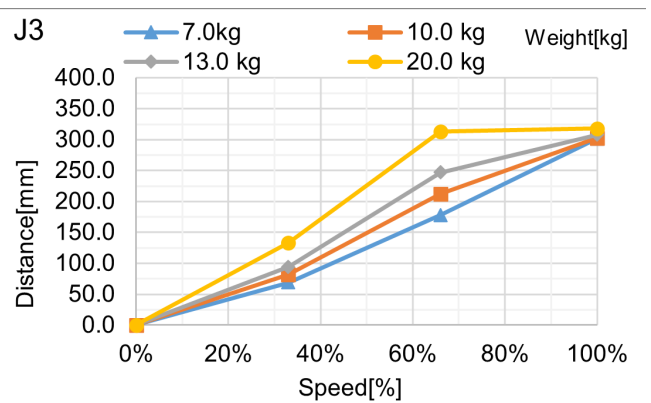
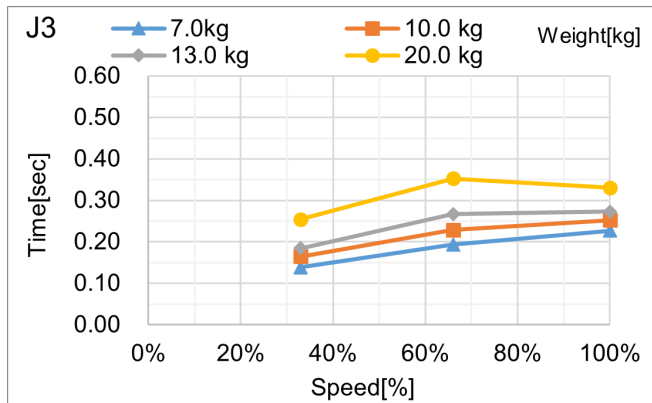

## 6.4.4 LS50-C Stopping Time and Stopping Distance when Safeguard is Opened

J1

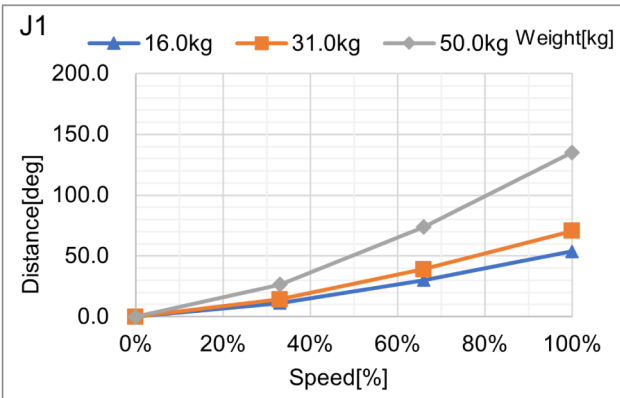
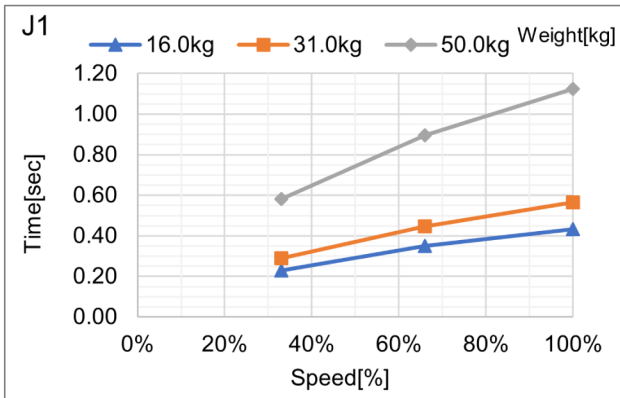

J2

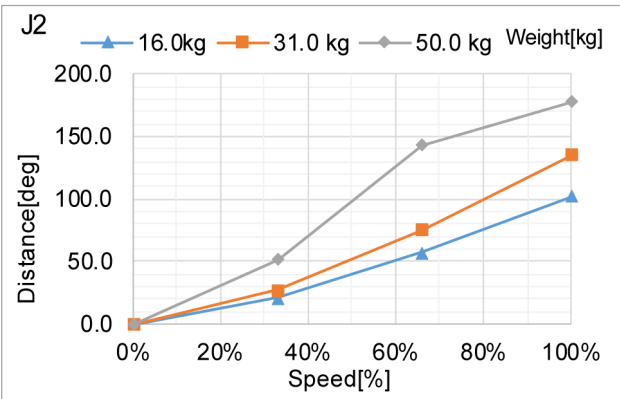
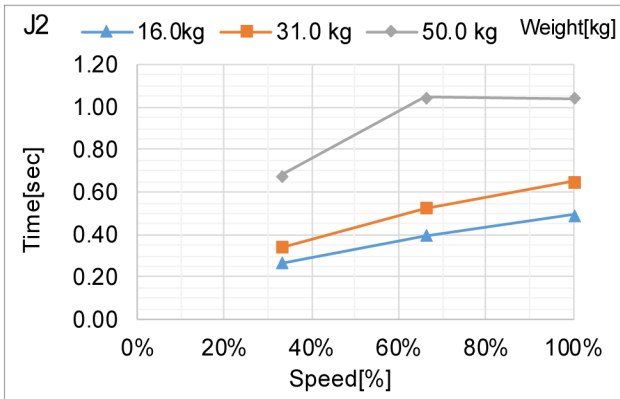

J3

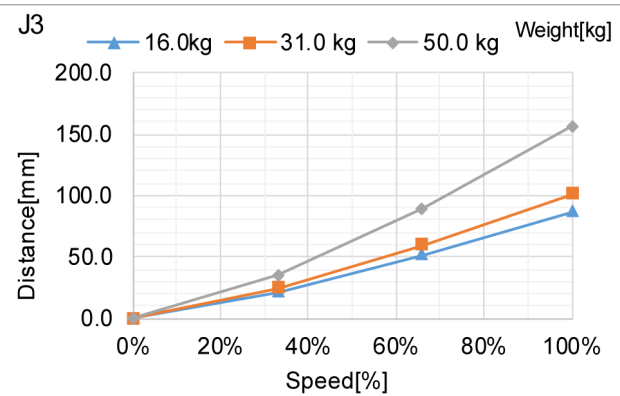
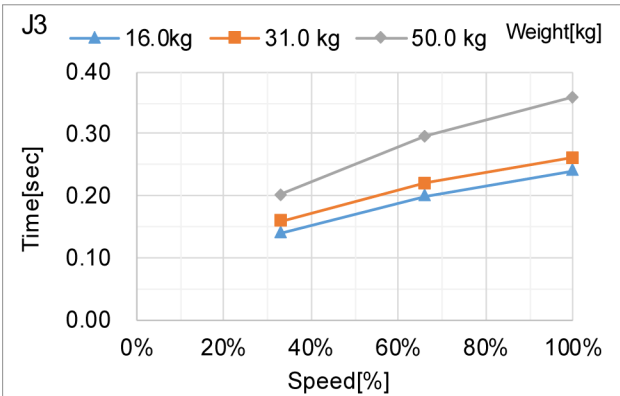

## 6.4.5 Supplementary Information of the Stopping Time and Stopping Distance When Safeguard is Open

The stopping time and stopping distance in Appendix. C were measured using the motion determined by us based on the ISO 10218-1.

Therefore, we cannot guarantee the maximum stopping time and stopping distance in your environment.

The stopping time and stopping distance varies depending on the Manipulator's model, motion, parameter and the timing in which the stop signal was input. Make sure to measure the stopping time and stopping distance according to the customer's environment.

### KEY POINTS

The following are included in the Manipulator's motion and parameter:

- The start, target and intermediate point of the motion
- Motion command (Go, Move, Jump etc.)
- Weight and Inertia Settings
- Things that change the motion speed, acceleration, deceleration, and motion timing

For details, refer to the following.

LS4-C, LS8-C:

[Weight and Inertia Settings](#)

LS20-C:

[Weight and Inertia Settings](#)

LS50-C:

[Weight and Inertia Settings](#)

### 6.4.5.1 How to check the stopping time and stopping distance in the customer's environment

Measure the stopping time and stopping distance of the actual operation with the following method:

1. Create a motion program in the customer's environment.
2. When the motion to check the stopping time and stopping distance starts, input the stop signal on your own timing.
3. Write down the time and distance of when the manipulator stops from the minute the stop signal is input.
4. Repeat 1 through 3 mentioned above and check the maximum stopping time and stopping distance.
  - How to input the stop signal: Manually operate the stop switch/safeguard or input by using the safety PLC.
  - How to measure the stopping position: Use a measure. You can also measure the angle with the Where or RealPos command.
  - How to measure the stopping time: Use a stop watch. You can also measure with the Tmr function.

### CAUTION

The stopping time and stopping distance varies depending on the timing that the stop signal was input. Perform a risk assessment based on the maximum stopping time and stopping distance and design the device to prevent the Manipulator from interfering with people and objects.

Therefore, make sure to always change the timing you input stop signal during the actual operation and continue to measure to get the maximum value.

To shorten the stopping time and stopping distance, use the safety limited speed (SLS) and limit the maximum speed. For details on the safety limited speed (SLS), refer to the following manual:

“Safety Function Manual”

### 6.4.5.2 Introduction of commands that are useful in measuring the stopping time and stopping distance

Commands	Functions
Where	Displays the data of the robot's current position.
RealPos	Returns the specified robot's current position. ※ Unlike the CurPos's motion target position, it receives the robot's position from the encoder.
PAgl	Returns by calculating the Joint's position from the specified coordinate value. P1 = RealPos 'Gets the current position. Joint1 = PAgl (P1, 1) ' Call for J1's angle from the current position
SF_RealSpeedS	Displays the current speed from the Safety Limited Speed in mm/s.
Tmr	The Tmr function returns the time, in seconds, since the timer starts.
Xqt	Runs the program specified by the function name and creates a task. Run the functions used to measure the stopping time and stopping distance with the task that was setup by installing the NoEmgAbort option. Run tasks that does not stop even with the emergency stop or when the safeguard is open.

For details, refer to the following manual.

“Epson RC+ SPEL+ Language Reference”