

Epson BrightLink Procedure for Measuring Projection Surface Flatness

When using a touch-enabled BrightLink projector, it is required that the projection surface is flat and have **no more than 5mm of curve** in order for the touch function to work properly. Prior to starting the install, you must check the projection surface to make sure that it meets this requirement.

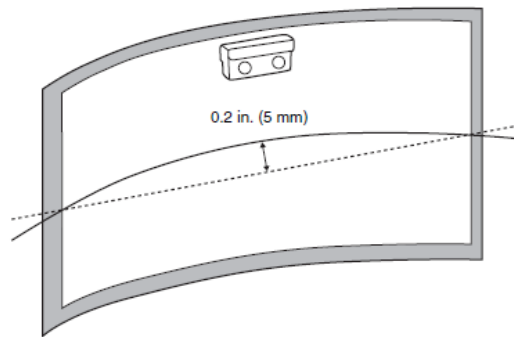

Required Tools:

Four-foot Level tool (1.2m /4') for testing flatness vertically

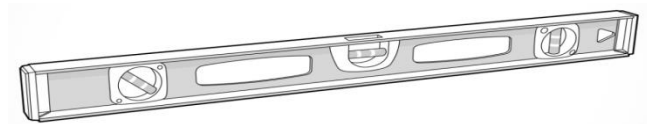

Five-foot level tool (1.5m/5') for testing flatness horizontally & diagonally

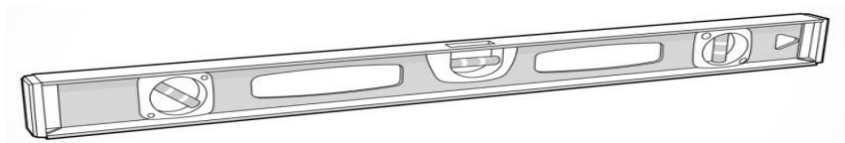

Metric thickness gauge (5mm)

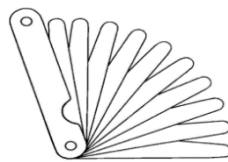

Assessing the Board – Multi-Point Flatness Test

The projection surface may be concave or convex or have other irregularities that will affect the calibration and performance of the touch functionality. For this reason it is important to conduct a multi-point flatness measurement.

Perform the following Multi-Point Flatness Test to determine if the projection surface is flat enough to proceed with installation of the BrightLink projector:

1. Divide the projection surface equally into 16 quadrants as shown below.

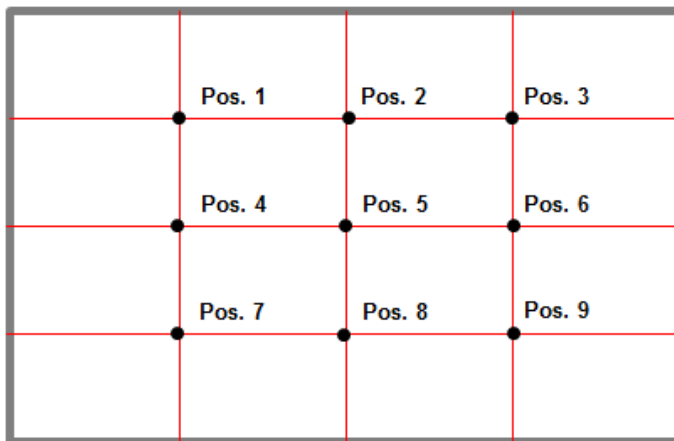

1. With the level tool(s) against the surface of the board at locations described in Steps 2 - 6, insert the 5mm thickness gauge at each position point on the projection surface. If the 5mm gauge is prevented from fitting under the level tool, the surface flatness is less than 5mm and it may be used for installing the BrightLink touch module.
2. Place the 4' level tool VERTICALLY across the projection surface at:
 - a. Position 1, 4, 7
 - b. Position 2, 5, 8
 - c. Position 3, 6, 9
3. Place the 5' level tool HORIZONTALLY across the projection surface at:
 - a. Position 1, 2, 3
 - b. Position 4, 5, 6
 - c. Position 7, 8, 9

4. Place the 5' level tool **DIAGONALLY** across the projection surface at:
 - a. Position 1, 5, 9
 - b. Position 3, 5, 7

5. Place the 5' level tool at position 8 and in a sweeping motion check the surface at:
 - a. Position 8, 4
 - b. Position 8, 1
 - c. Position 8, 3
 - d. Position 8, 6

6. Place the 5' level tool at position 2 and in a sweeping motion check the surface at:
 - a. Position 2, 4
 - b. Position 2, 7
 - c. Position 2, 9
 - d. Position 2, 6

Note: If there are any visible bumps or indentations elsewhere on the board surface, perform additional horizontal and vertical measurements at those points as described in the instructions above.