



Safety Manual

This manual describes precautions for using the robot system safely. Be sure to read this before using the robot system.

After reading this manual, store it in an easily accessible location for future reference.

RC800-A
Original instructions
Main doc. No. MD002

©Seiko Epson Corporation 2024

Rev.2
ENM247B6710F

Table of Contents

1. Introduction	5
1.1 Introduction	6
1.2 Trademarks	6
1.3 Terms of Use	6
1.4 Manufacturer	7
1.5 Importers	7
1.6 Contact Information	7
1.7 Disposal	11
1.8 Disposal of Batteries	11
1.8.1 For Customers in the European Union	11
1.8.2 For Customers in the Taiwan Region	12
1.8.3 For California Customers	12
2. Safety of This Product	13
2.1 Application and Purpose of This Product	14
2.2 Installation Environment	14
2.3 Residual Risks	15
2.4 Declaration of Conformity	16
2.5 Safety Compliance	18
2.6 Notes on CE Marking	19
2.7 Notes on UKCA Marking	20

3. Safety Precautions	21
3.1 Conventions Used in This Manual	22
3.2 Precautions for Unpacking and Transportation	23
3.3 Precautions for Installation and Connection	25
3.4 Precautions for Teaching and Programming	32
3.5 Precautions for Automatic Operation	34
3.6 Precautions for Maintenance	37
3.7 Controller Labels	40
3.7.1 Warning Labels	40
3.7.2 Labels	41
3.7.3 Labelled Locations	42
3.8 Manipulator Labels	43
3.8.1 Warning Labels	43
3.8.2 Labels	44
3.8.3 Labelled Locations	45
3.8.3.1 GX-C Series	45
3.8.3.1.1 GX4-C	45
3.8.3.1.2 GX8-C	47
3.8.3.1.3 GX10-C/GX20-C	49
3.9 Safety Functions	51
3.10 Protective Functions	54

- 4. Role and Training for Safety Managers 56**
 - 4.1 Role for Safety Managers 57
 - 4.1.1 Password management 57
 - 4.1.2 Training implementation 58
 - 4.2 Knowledge and Training Required to Work with Robot Systems 59

- 5. Manuals for This Product 61**
 - 5.1 Manual Types 62
 - 5.2 Viewing Manuals 63
 - 5.3 Installing the Software and Manuals 64

- 6. Process from Unpacking to Disposal 65**
 - 6.1 Handling from Unpacking to Disposal 66

- 7. Appendix 68**
 - 7.1 Appendix: China RoHS 69

1. Introduction

1.1 Introduction

Thank you for purchasing this Epson robot system. This manual provides the information necessary for correctly using the robot system.

Before using the system, please read this manual and related manuals to ensure correct use.

After reading this manual, store it in an easily accessible location for future reference.

Epson conducts rigorous testing and inspection to ensure that the performance of our robot systems meets our standards. Please note that if the Epson robot system is used outside the operating conditions described in the manual, the product will not perform up to its basic performance.

This manual describes potential hazards and problems that are foreseen. To use the Epson robot system safely and correctly, be sure to follow the safety information contained in this manual.

1.2 Trademarks

Microsoft, Windows, and the Windows logo are either registered trademarks or trademarks of Microsoft Corporation in the United States and/or other countries. All other company names, brand names, and product names are registered trademarks or trademarks of their respective companies.

1.3 Terms of Use

No part of this instruction manual may be reproduced or reprinted in any form without express written permission.

The information in this document is subject to change without notice.

Please contact us if you find any errors in this document or if you have any questions about the information in this document.

1.4 Manufacturer

SEIKO EPSON CORPORATION

3-5, Owa 3-chome, Suwa-shi, Nagano 392-8502 Japan

URL : <https://www.epson.jp/company/>

URL : <https://www.epson.jp/prod/robots/>

Toyoshina Plant Manufacturing Solutions Division

6925 Tazawa, Toyoshina, Azumino, Nagano, 399-8285, Japan

TEL : 0263-72-1530

FAX : 0263-72-1685

1.5 Importers

- **Importer for the EU**

- **EPSON EUROPE B.V.**

- Azie building, Atlas Arena, Hoogoorddreef 5,1101

- BA Amsterdam Zuidoost The Netherlands

- TEL: +31-20-314-5000

- FAX: +31-20-314-5010

- **Importer for the UK**

- **EPSON EUROPE B.V.**

- Floor 3&4, The Clarendon Works, 37-39 Clarendon Road,

- Watford WD17 1JA, U.K.

- TEL: +44-1442-261144

- FAX: +44-1442-227227

1.6 Contact Information

SUPPLIER (Country/Region)

- **North and South America: Epson America, Inc.**

- Factory Automation/Robotics

- 3131 Katella Ave., Los Alamitos, CA 90720,

- U.S.A

TEL : +1-562-981-3840

FAX : +1-562-981-5220

E-MAIL : info@robots.epson.com

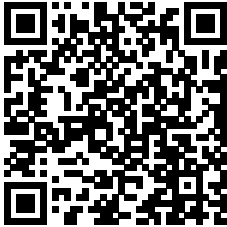

■ **Europe: Epson Deutschland GmbH**

Manufacturing Solutions

Schiessstrasse 49, 40549 Dusseldorf

Germany

TEL : +49-(0)-211-54229-009

FAX : +49-(0)-211-54229-001

E-MAIL : service.ms@epson.eu

URL : www.epson.de/robots

■ **Chinese mainland Epson (China) Co., Ltd.**

Robotics Division

4F, Tower 1, China Central Place,

81 Jianguo Road, Chaoyang District,

Beijing, 100025, PRC

TEL : +86-(0)-10-8522-1199

FAX : +86-(0)-10-8522-1125



- **Taiwan region: Epson Taiwan Technology & Trading Ltd.**

Manufacturing Solutions Business Unit

15F, No.100, Song Ren Road, Sinyi Dist. Taipei City 11073,

Taiwan

TEL : +886-(0)-2-8786-6688

FAX : +886-(0)-2-8786-6600

E-MAIL : info.ms@exc.epson.com.tw

URL : <https://www.epson.com.tw/robot-tech#>

INQUIRY WEB PAGE: <https://www.epson.com.tw/contactrobot>



- **Korea: Epson Korea Co., Ltd.**

MS Business Team

10F Posco Tower Yeoksam, Teheranro 134(Yeoksam-dong)

Gangnam-gu, Seoul, 06235

Korea

TEL : +82-(0)-2-3420-6632

FAX : +82-(0)-2-558-4271

E-MAIL : info.ms@epson.co.kr

URL : www.epson.co.kr

- **Southeast Asia: Epson Singapore Pte. Ltd.**

Factory Automation System

438B Alexandra Road,

Block B Alexandra TechnoPark, #04-01/04,

Singapore 119968

TEL : +65-(0)-6586-5500

FAX : +65-(0)-6271-7066

- **India: Epson India Pvt. Ltd.**

Sales & Marketing (Factory Automation)

12th Floor, The Millenia, Tower A, No. 1,

Murphy Road, Ulsoor, Bangalore,

India 560008

TEL : +91-80-4566-5000

FAX : +91-80-4566-5005

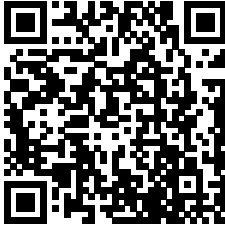

- **Japan: Epson Sales Japan Corporation**

JR Shinjuku Miraina Tower, 4-1-6 Shinjuku, Shinjuku-ku, Tokyo 160-8801 Japan

Installation & Online Business Consultation

TEL : 03-5919-5257

E-MAIL : epson-robot@exc.ehb.epson.co.jp

Technical & Repair Support

TEL : 042-847-3035

E-MAIL : Robot.Tech@exc.ehb.epson.co.jp

URL : www.epson.jp/products/robots/



1.7 Disposal

When disposing of this product, please do so in accordance with the laws and regulations of your country.

1.8 Disposal of Batteries

Refer to the following manual for the battery removal and replacement procedures.
"Service Manual"

1.8.1 For Customers in the European Union



The crossed out wheeled bin label that can be found on your product indicates that this product and incorporated batteries should not be disposed of via the normal household waste stream.

To prevent adverse effects on the environment and human health, the product and its batteries should be separated from other waste and recycled in an environmentally responsible manner. Contact your local government or product distributor for information on collection facilities.

The Pb, Cd, or Hg symbol means that these metals are used in the battery.



KEY POINTS

This information only applies to customers in the European Union, according to Directive 2006/66/EC OF THE EUROPEAN PARLIAMENT AND OF THE COUNCIL OF 6 September 2006 on batteries and accumulators and waste batteries and accumulators and repealing Directive 91/157/EEC and legislation transposing and implementing it into the various national legal

systems, and to customers in countries in Europe, Middle East and Africa (EMEA) where they have implemented equivalent regulations.

For information on recycling products in other countries, please contact your local government.

1.8.2 For Customers in the Taiwan Region



Used batteries should be separated from other waste and recycled in an environmentally responsible manner. Contact your local government or product distributor for information on collection facilities.

1.8.3 For California Customers

The coin cell manganese dioxide lithium battery used in this product contains perchlorate material that requires special handling.

Refer to the following document.

<https://dtsc.ca.gov/perchlorate/>

2. Safety of This Product

2.1 Application and Purpose of This Product

This product is intended for transporting and assembling parts in a safety isolated area and dedicated to Epson robots used in industrial environments.

2.2 Installation Environment

A suitable environment is necessary to maintain the functionality of the robot system and ensure its safe use. Install the robot system in a location that meets the following conditions.

- **Ambient temperature**

Installation: 5 to 40°C

Transportation or storage: -20 to 60°C

- **Ambient relative humidity (no condensation)**

Installation: 10 to 80% (GX-C), 20 to 80% (RC800-A)

Transportation or storage: 10 to 90%

- **Fast transient burst noise**

1 kV or less (signal wire)

- **Electrostatic noise**

4 kV or less

- **Altitude**

GX4-C, GX8-C: 2000 m or less

GX10-C, GX20-C : 1000 m or less

- **Environment**

- Install indoors.
- Keep away from direct sunlight.
- Keep away from dust, oily smoke, salinity, metal powder, and other contaminants.
- Keep away from flammable or corrosive liquids and gases.

- Keep away from water.
- Keep away from shocks or vibrations.
- Keep away from sources of electric noise.
- Keep away from explosive areas.
- Keep away from large quantities of radiation.

2.3 Residual Risks

For more details about the residual risks present in our Manipulator and Controller, check the warnings and caution statements in each section.

2.4 Declaration of Conformity

EPSON

Translation

- Original -
French (FR)

DECLARATION OF INCORPORATION OF PARTLY COMPLETED MACHINERY

DÉCLARATION D'INCORPORATION POUR LES QUASI-MACHINES

According to the Machinery Directive 2006/42/EC, Annex II ,Part1,sector B for a partly completed machinery.
En accord avec la directive machine 2006/42/CE, Annexe II, Partie 1, Secteur B pour une quasi-machine.

Manufacturer /Fabricant:	SEIKO EPSON CORPORATION	www.epson.com
Address /Adresse:	3-5, Owa 3-chome, Suwa-shi Nagano-ken 392-8502 Japan	Telephone /Téléphone: +81-266-52-3131 Fax /Fax: +81-266-52-8409

Representative /Représentant:	EPSON EUROPE B.V.	www.epson.eu
Address /Adresse:	Atlas Arena, Asia Building, Hoogoorddreef 5,1101 BA Amsterdam Zuidoost The Netherlands	Telephone /Téléphone: +31-20-314-5000

Declares under our sole responsibility that the product:
Déclare sous notre seule responsabilité que le produit :

Brand Name /Nom de la marque:	EPSON
Product Name /Nom du produit:	Industrial Robot/ Robot Controller GX4-C,GX8-C,GX10-C,GX20-C R131(x=A or B)(RC800-A)
Model /Model:	(Serial number G*****0001 - G*****9999) (Serial number R8A***0000 - R8A***FFFF) <Note> *: 0 - 9, A - Z

For more details, please refer to the product description
Pour plus de détails, merci de vous référer à la description du produit

Options /Options:

See Technical Data File

Fulfills the following essential health and safety requirements of the Machinery Directive 2006/42/EC:
Répond aux exigences essentielles de santé et de sécurité de la directive machine 2006/42/CE.

1.1.2, 1.1.3, 1.1.5, 1.1.6, 1.2.1, 1.2.2, 1.2.3, 1.2.4.1, 1.2.4.3, 1.2.5, 1.2.6, 1.3.1, 1.3.2, 1.3.3, 1.3.4, 1.3.6, 1.3.7, 1.3.9, 1.5.1, 1.5.2,
1.5.4, 1.5.6, 1.5.8, 1.5.9, 1.5.10, 1.5.11, 1.6.1, 1.6.2, 1.6.3, 1.6.4, 1.7.1, 1.7.1.1, 1.7.2, 1.7.3, 1.7.4

The manufacturer undertakes to electronically supply the relevant technical documentation, referred to in Annex VII part B for the partly completed machinery, to national authorities upon reasoned request.

La fabricant s'engage à fournir électroniquement la documentation technique pertinente aux autorités Nationales sur demande motivée, selon l'annexe VII Partie B pour les Quasi-machines.

This partly completed machine must not be put into service until the machinery into which it is to be incorporated, has been declared in conformity with the provisions of the Machinery Directive.

La quasi-machine ne doit pas être mise en service tant que l'équipement d'incorporation n'aura pas été déclarée conforme aux dispositions de la directive machine.

Furthermore this partly completed machinery fulfils all relevant provisions of the directive:

En outre, cette quasi-machine remplit toutes les dispositions pertinentes de cette directive:

- Electromagnetic Compatibility (EMC) 2014/30/EU
- Restriction of the use of certain hazardous substances (RoHS)2011/65/EU (except options)

Following harmonized norms and specifications are applied:

L'harmonisation des normes et des spécifications suivantes sont appliquées :

Safety:

EN ISO 10218-1	2011	IEC 61508-1	2010
EN ISO 12100	2010	IEC 61508-2	2010
EN 60204-1	2018	IEC 61508-3	2010
EN ISO 13850	2015		
EN 61800-5-1	2007/A11:2021		
EN 61800-5-2	2017		
EN ISO 13849-1	2015		
IEC 62061	2021		

EMC:

EN 55011	2016/A1:2017/A11:2020 Group1 Class A
EN 61000-6-2	2005
EN 61000-6-4	2007/A1:2011
EN 61000-6-7	2015

RoHS:

EN IEC 63000	2018
--------------	------



	DECLARATION OF INCORPORATION OF PARTLY COMPLETED MACHINERY
--	---

According to Supply of Machinery (Safety) Regulations 2008, SCHEDULE2, PART2, sector 1.B. for a partly completed machinery.

Manufacturer	SEIKO EPSON CORPORATION	www.epson.com	
Address	3-5, Owa 3-chome, Suwa-shi Nagano-ken 392-8502 Japan	Telephone	+81-266-52-3131
		Fax	+81-266-52-8409
Representative	Epson (U.K.) Limited	www.epson.co.uk	
Address	Floor 3&4, The Clarendon Works, 37-39 Clarendon Road, Watford WD17 1JA, U.K.	Telephone	+44-1442-261144

Declares under our sole responsibility that the product:

Brand Name	EPSON		
Product Name	Industrial Robot/ Robot Controller		
Model	GX4-C,GX8-C,GX10-C,GX20-C R131(x=A or B)(RC800-A)		(Serial number G****0001 - G****9999) (Serial number R8A***0000 - R8A****FFF) <Note> * : 0 - 9, A - Z
	For more details, please refer to the product description		

Options

See Technical Data File

Fulfills the following essential health and safety requirements of the Supply of Machinery (Safety) Regulations 2008:

- 1.1.2, 1.1.3, 1.1.5, 1.1.6, 1.2.1, 1.2.2, 1.2.3, 1.2.4.1, 1.2.4.3, 1.2.5, 1.2.6, 1.3.1, 1.3.2, 1.3.3, 1.3.4, 1.3.6, 1.3.7, 1.3.9, 1.5.1, 1.5.2, 1.5.4, 1.5.6, 1.5.8, 1.5.9, 1.5.10, 1.5.11, 1.6.1, 1.6.2, 1.6.3, 1.6.4, 1.7.1, 1.7.1.1, 1.7.2, 1.7.3, 1.7.4

The manufacturer undertakes to electronically supply the relevant technical documentation, referred to in Part7 sector B for the partly completed machinery, to national authorities upon reasoned request.

This partly completed machine must not be put into service until the machinery into which it is to be incorporated, has been declared in conformity with the provisions of the Machinery (Safety) Regulations.

Furthermore this partly completed machinery fulfils all relevant provisions of the directive:

- Electromagnetic Compatibility Regulations 2016
- The Restriction of the Use of Certain Hazardous Substances in Electrical and Electronic Equipment Regulations 2012 (except options)

Following harmonized norms and specifications are applied:

Safety:					
EN ISO 10218-1	2011	IEC 61508-1	2010	EMC:	
EN ISO 12100	2010	IEC 61508-2	2010	EN 55011	2016/A1:2017/A11:2020 Group1 Class A
EN 60204-1	2018	IEC 61508-3	2010	EN 61000-6-2	2005
EN ISO 13850	2015			EN 61000-6-4	2007/A1:2011
EN 61800-5-1	2007/A11:2021			EN 61000-6-7	2015
EN 61800-5-2	2017			RoHS:	
EN ISO 13849-1	2015			EN IEC 63000	2018
IEC 62061	2021				

2.5 Safety Compliance

Specific tolerances and conditions of use for ensuring safety are described in the manuals for the Manipulators and Controllers. Be sure to also read these manuals.

Observe the safety standards of the respective country and region when installing and operating the robot system. The following are examples of safety standards related to robot systems and other safety standards.

Please refer not only to this chapter but also to these standards and take adequate safety measures.

Note: These standards are not intended to include all of the required safety standards.

- **ISO 10218-1**
Robots and robotic devices -- Safety requirements for industrial robots -- Part 1: Robots
- **ISO 10218-2**
Robots and robotic devices -- Safety requirements for industrial robots -- Part 2: Robot systems and integration
- **ANSI/RIA R15.06**
American National Standard for Industrial Robots and Robot Systems -- Safety Requirements
- **ISO 12100**
Safety of machinery -- General principles for design -- Risk assessment and risk reduction
- **ISO 13849-1**
Safety of machinery -- Safety-related parts of control systems -- Part 1: General principles for design
- **ISO 13850**
Safety of machinery -- Emergency stop function-- Principles for design

- **ISO 13855**
Safety of machinery -- Positioning of safeguards with respect to the approach speeds of parts of the human body.
- **ISO 13857**
Safety of machinery -- Safety distances to prevent hazard zones being reached by upper and lower limbs.
- **ISO14120**
Safety of machinery -- Guards -- General requirements for the design and construction of fixed and movable guards
- **IEC 60204-1**
Safety of machinery -- Electrical equipment of machines -- Part 1: General requirements
- **CISPR11**
Industrial, scientific and medical (ISM) radio-frequency equipment -- Electromagnetic disturbance characteristics -- Limits and methods of measurement
- **IEC 61000-6-2**
Electromagnetic compatibility (EMC) -- Part 6-2: Generic standards -- Immunity for industrial environments

2.6 Notes on CE Marking

Epson robot system (Manipulators and Controllers) is a device that will be incorporated into the end user manufacturing equipment, so it is a "partly completed machinery" which defined in subparagraph 1 (g) of Article 1 (Scope) of the European Machinery Directive (2006/42/EC). Pursuant to the Article 13 (Procedure for partly completed machinery) of the European Machinery Directive, Epson has declared that the Epson robot system conforms to the European Machinery Directive, the European EMC Directive (2014/30/EU), and the European RoHS Directive (2011/65/EU) in the "Declaration of Incorporation of Partly Completed Machinery." (Please refer to the Declaration of Incorporation of Partly Completed Machinery included with the robot system for details.) Therefore, the Epson Manipulators do not bear the CE marking because the Epson robot system is a "partly completed machinery."

However, the Robot Controller RC800-A is considered as a "completed product." Epson has separately declared that RC800-A conforms to the European EMC Directive and the European RoHS Directive, and RC800-A bears the CE marking as proof of conformity.

2.7 Notes on UKCA Marking

Epson robot system (Manipulators and Controllers) is a device that will be incorporated into the end user manufacturing equipment, so it is a "partly completed machinery" which defined in subparagraph (1) of regulation 6 of the Supply of Machinery (Safety) Regulations 2008. Pursuant to the regulation 8 of Supply of Machinery (Safety) Regulations 2008, Epson has declared that the Epson robot system conforms to the Supply of Machinery (Safety) Regulations 2008, the Electromagnetic Compatibility Regulations 2016, and the Restriction of the Use of Certain Hazardous Substances in Electrical and Electronic Equipment Regulations 2012 in the "Declaration of Incorporation of Partly Completed Machinery." (Please refer to the Declaration of Incorporation of Partly Completed Machinery included with the robot system for details.) Therefore, the Epson Manipulators do not bear the UKCA marking because the Epson robot system is a "partly completed machinery."

However, the Robot Controller RC800-A is considered as a "completed product." Epson has separately declared that RC800-A conforms to the Electromagnetic Compatibility Regulations 2016 and the Restriction of the Use of Certain Hazardous Substances in Electrical and Electronic Equipment Regulations 2012, and RC800-A bears the UKCA marking as proof of conformity.

3. Safety Precautions

This chapter describes caution statements for using the robot system safely. Be sure to read this before using the robot system.

Using the robot system without understanding the safety information can be extremely hazardous and may result in serious injury to operators and/or severe equipment damage.

3.1 Conventions Used in This Manual

The following symbols are used in this manual to indicate important safety information. Be sure to read the descriptions shown with each symbol.

WARNING

This symbol indicates an imminently hazardous situation which, if operation is not performed properly, will result in death or serious injury.

WARNING

This symbol indicates a potentially hazardous situation which, if operation is not performed properly, could result in an injury due to electric shock.

CAUTION

This symbol indicates a potentially hazardous situation which, if operation is not performed properly, may result in an injury or in property damage only.

3.2 Precautions for Unpacking and Transportation

Unpacking and transportation of the Manipulator and related equipment should be performed by people who have received installation training provided by Epson and the suppliers. Also, the laws and regulations of the installation country must be followed. The following items are safety precautions that must be observed.

WARNING

- When transporting the Manipulator, use a cart or the like to transport it in the same status as it was delivered. Do not transport with the end effector or peripheral equipment attached. Losing balance may cause the Manipulator to fall over, which is extremely hazardous and may result in serious injury to operators and/or severe equipment damage.
- Only qualified personnel should perform sling work and operate a crane or a forklift. When these operations are performed by unqualified personnel, it is extremely hazardous and may result in serious injury to operators and/or severe equipment damage.
- When hoisting the Manipulator, use your hands to balance it. Losing balance may cause the Manipulator to drop, which is extremely hazardous and may result in serious injury to operators and/or severe equipment damage.
- During transport, personnel involved in the work should wear helmets and other personal protective equipment. Also, make sure there are no other people in the vicinity.

CAUTION

- Avoid excessive vibration and shocks when transporting the Manipulator. Excessive vibration and shock may cause Manipulator damage or malfunctions.
- When removing the fixing bolts securing the Manipulator to the transportation pallet or the anchor bolts, support the Manipulator to

prevent it falling. Removing the fixing bolts or anchor bolts without supporting the Manipulator may cause it to fall, catching your hands or feet.

- Do not remove the cable ties securing the arm until installation is complete. Removing the cable ties may cause your hand or fingers to be caught in the Manipulator.
- To transport the Manipulator, either secure it to transporting equipment, or use the transport method and number of personnel specified in the Manipulator Manual. Do not put your hand on any areas that specify holding restrictions.

3.3 Precautions for Installation and Connection

The robot system should be installed and connected by people who have received installation training provided by Epson and the suppliers. The following items are safety precautions that must be observed.

WARNING

- The serial number of the supported Manipulator is labeled on the Controller. Check that the serial number matches for each device. Improper connection between the Manipulator and the Controller may not only lead to malfunction of the robot system but also safety problems.
- The robot system must be used within the environmental conditions described in the respective manuals. This product has been designed and manufactured for use in a normal indoor environment. Use of the product in an environment that does not meet the operating environmental conditions will not only shorten the product life, but may also cause serious safety issues.
- The robot system must be used within the specified specifications. Using the robot system outside of the product specifications will not only shorten the product life, but may also cause serious safety issues.
- When installing a robot system, wear at least the following protective gear. Working without protective gear may cause serious safety problems.
 - Work clothes suitable for work
 - Helmet
 - Safety shoes
- When designing a robot system using this product, refer to "Designing a Safe Robot System" in the Controller manual or refer to the standards to install safety barriers. Failure to install safety barriers is extremely hazardous and may result in serious injury to operators and/or severe equipment damage.

- Be sure to install an emergency stop device that allows the operator to stop the system immediately. Failure to install an emergency stop device is extremely hazardous and may result in serious injury to operators and/or severe equipment damage.
- Install the Manipulator in a location with enough space so that a tool or a workpiece tip does not reach a wall or safety barriers when the Manipulator extends its arm while holding a workpiece. If the tool or the workpiece tip reaches a wall or safety barriers, it is extremely hazardous and may result in serious injury to operators and/or severe equipment damage.

The distance between the safety barriers and the tool or workpiece should be set according to ISO 10218-2. For the stopping time and stopping distance, refer to the following manuals.

"Manipulator Manual - Appendix B: Stopping Time and Stopping Distance at Emergency Stop"

"Manipulator Manual - Appendix C: Stopping Time and Stopping Distance When Safeguard Is Open"

- Before installing or operating the Manipulator, make sure that no parts of the Manipulator are missing and that it has no damage or other external defects. Missing parts or damage may cause malfunction of the Manipulator, is extremely hazardous and may result in serious injury to operators and/or severe equipment damage.
- Do not use the Manipulator near devices that generate strong magnetic forces. This may cause Manipulator failure or malfunction.
- Do not use the Manipulator in areas where there is a risk of electromagnetic interference, electrostatic discharge, or radio frequency interference. This is dangerous because the Manipulator may malfunction.
- Do not use the Manipulator where it is exposed to combustible gases, combustible dusts, gasoline, solvents, or other flammable liquids that may cause an explosion or fire. This may cause serious accidents involving injury or death as well as fires.

- Keep hands and other objects away from moving parts of the Manipulator. There is a risk of injury due to pinching.
- Do not install the Controller upside down or at an angle.
- For protected-model

Connect the power cable connector and the signal cable connector to the connector plate immediately after installing the Manipulator. When the Manipulator is unconnected, protection at IP65 cannot be ensured.

This may result in electric shock and/or malfunction of the robot system.

- If the Manipulator is installed on a movable platform (linear axis, movable cart, AGV, etc.), be sure to design the system so that the movable platform also stops when the Manipulator is stopped in an emergency. If the movable platform continues to operate without stopping, it is extremely hazardous and may result in serious injury to operators and/or severe equipment damage.



WARNING

- Always use a power plug or a disconnecting device for the power cable, and never connect directly to the factory power supply or the like.
- Do not open the cover of the Controller or Manipulator except during maintenance. There is a high-voltage charging section inside, and there is a risk of electric shock even when the power is turned off.
- Be sure to turn off the power to the robot system before connecting or disconnecting cables. Working with the power on may result in electric shock and/or malfunction of the robot system.
- Use cables with securely protected high-voltage sections and connect them securely. Also, do not put heavy objects on the cables, bend them severely, pull them forcibly, or pinch them. Damaged cables, broken wires, or contact failure is extremely hazardous and may result in electric shock and/or malfunction of the robot system.
- If installing a power plug to match a factory power socket, the installation should be performed by personnel with specialized knowledge and skills

in the field. When installing the power plug, be sure to connect the ground wire (green/yellow) of the AC power cable to the ground terminal of the power distribution system. If the ground wire is improperly connected to ground, it may result in the electric shock.

- Always use a circuit breaker for the Controller's power supply. Failure to use a circuit breaker may result in electric shock and/or malfunction of the robot system.
- When connecting the Controller power supply to a transformer, connect the N and PE terminals of the AC power cable to the neutral terminal of the transformer.
- Installation for options should be performed by people who have received maintenance training provided by Epson and the suppliers. Be sure to turn off the power to the robot system and disconnect the power cables during work. Working with the power on or with the high-voltage charging sections not fully discharged may result in electric shock and/or serious safety problems.
- Remove the power plug when opening the front of the Controller. Touching the AC power input terminal block or other components inside the enclosure may result in electric shock and/or serious safety problems.
- The Manipulator is grounded by connecting it to the Controller. Ensure that the Controller is grounded and the cables are correctly connected. If the ground wire is improperly connected to ground, it may result in the fire or electric shock.
- Be sure to turn off the power and tag out (e.g., with a "DO NOT TURN ON" sign) before performing wiring. Performing any work procedure with the power turned on is extremely dangerous and may result in electric shock and/or malfunction of the robot system.
- If there is a brake release unit and external short connector
Turn off the power to the Controller and brake release unit when connecting or replacing the brake release unit or external short connector. Inserting or removing connectors with the power on may result in electric shock and/or malfunction of the robot system.

- Do not touch the terminals. Doing so may cause electric shock, product damage, or malfunction.

CAUTION

- Regarding the necessity for organizational measures for cyber security
Organizational measures like those described below should be taken to address cybersecurity risks:
 - Perform risk analysis based on security threats and vulnerabilities related to your organization's assets.
 - Establish a security policy to address risks and educate and train appropriate personnel.
 - Establish guidelines for how to respond when security issues arise and make them known throughout your organization.
- Epson robot systems are designed to be used within a closed local area network. Please refrain from connecting to networks with Internet access. If a connection to the Internet is required, we recommend taking the necessary technical measures* to protect against malicious attacks and vulnerabilities over the Internet.
*: These measures include, but are not limited to, access controls, firewalls, data diodes, and so on.
- Do not connect any devices other than those listed in the manual to the external connection terminals of this product. Do not use the external connection terminals for any purpose other than those described in the manual. Failures such as unauthorized logins, information falsification, information leaks, and robot system stoppages may occur. We recommend taking physical measures to prevent anyone other than the administrator and those authorized by the administrator from touching the Controller and control devices. Furthermore, we recommend taking technical and physical measures to prevent access to the network to which the product is connected.

- When using I/O with remote settings, pay attention to the following points. Using I/O with remote settings without satisfying the requirements may lead to system failure or safety issues.
 - When making settings, do not make a mistake in the relationship between function assignments and wiring.
 - Be sure to check the correspondence between the functions and wiring before turning the system on.
 - When checking operation, try to anticipate configuration or wiring errors.

If the Manipulator performs an abnormal operation due to a setting or wiring error, do not hesitate to immediately stop Manipulator operation by pressing the emergency stop switch or by other means.

- Resonance (resonating sound or minute vibrations) may occur during Manipulator operation depending on the rigidity of the base table. If the resonance occurs, improve the rigidity of the base table or change the speed or acceleration and deceleration settings of the Manipulator.
- Only authorized or certified personnel should perform wiring. Wiring by unauthorized or uncertified staff may result in bodily injury and/or malfunction of the robot system.
- Wall mounting, ceiling mounting
In case of wall mounting or ceiling mounting, secure the Manipulator to a wall or ceiling with enough strength and rigidity. Also, take measures on the base of the Manipulator to prevent it from falling. If the Manipulator vibrates or drops, it is extremely hazardous and may result in serious injury to operators and/or severe equipment damage.
- Be careful to prevent any foreign material, such as shavings or wiring scraps, from entering the Controller. Foreign objects may cause malfunction, failure, or fire.
- Do not apply shocks or loads to the connectors when connecting cables.
- When removing a cable, do not pull on the cable portion.

- Check that the serial number matches for each device. Improper connection between the Manipulator and the Controller may not only lead to malfunction of the robot system but also safety problems.
- Before connecting the connector, check that the pins are not bent. Connecting with pins bent may damage the connector and result in malfunction of the robot system.
- If there is a brake release unit and external short connector
Operating the Manipulator without a brake release unit or external short connector connected may cause the brake to fail to release, possibly damaging the brake.
After using the brake release unit, be sure to connect the external short circuit connector to the Manipulator or make sure to leave the connector for the brake release unit connected.

3.4 Precautions for Teaching and Programming

The following items are safety precautions for personnel performing teaching or programming.

WARNING

- Incorrectly configured safety functions may cause serious safety problems.
- The interlocks of the safeguards must be functioning when performing work. Performing work in a state where the switch does not turn ON or OFF, such as if it is covered with tape (in a state where the switch is disabled), is extremely hazardous because the safety function of the safeguard input will not be activated. This may cause serious safety problems.
- Be sure to anchor the Manipulator before turning on the power or operating it. Turning on the power or operating the Manipulator while it is not anchored may cause the Manipulator to fall over, which is extremely hazardous and may result in serious injury to operators and/or severe equipment damage.
- Persons who have not undergone training must never approach a Manipulator that is turned on. Also, do not enter the work envelope. If the Manipulator is turned on, it may make unexpected movements even if it appears to be stopped, which may result in serious safety problems. Also, safe work procedures should be established and followed to prevent hazards due to unexpected movement of the Manipulator or operator mishandling of the Manipulator.
- Before beginning full operation, make sure that the safety devices such as the emergency stop switch and the interlocked guard switch operate. Operation without the switches functioning properly may result in the safety functions failing to operate during an emergency, which is extremely hazardous and may result in serious injury to operators and/or severe equipment damage.

- The mode selector key switch of the Teach Pendant does not comply with functional safety.
- During teach points and start-up work, the robot system should be in teach mode, with the emergency stop switch ready to be pressed at any time. Mistaken operations or the like could cause the Manipulator to make an unexpected movement, which is extremely hazardous and may cause serious safety problem.
- When working inside the safety barriers, use the teaching operation mode (low speed, low power).

CAUTION

- Whenever possible, only one person should operate the robot system. If it is necessary to operate with more than one person, ensure that all personnel communicate with each other and take all necessary safety precautions. Also, when working close to the robot, take safety precautions such as assigning a supervisor.
- SCARA robot
When pressing the brake release switch, watch for the shaft descending or rotating under the weight of the hand. The arm falling may result in hands or fingers getting caught or Manipulator damage or breakdown.

3.5 Precautions for Automatic Operation

The following items are safety precautions for personnel running a program to perform automatic operation.

WARNING

- Do not carelessly enter the work envelope during automatic operation. This is extremely hazardous and may cause serious safety problems because the Manipulator may move, even if it seems to be stopped.
- If the Manipulator stops for an unknown reason during automatic operation, absolutely do not approach the stopped Manipulator. If you need to approach the Manipulator, press the emergency stop switch or shut off the main power supply before approaching. When shutting off the main power supply, be very careful not to create new hazards.
- When interrupting a program and restarting the robot system during automatic operation, make sure that no new hazards are created in relation to peripheral equipment before starting the program.
- Before operating the robot system, make sure that no one is inside the safety barriers. If the Manipulator makes an unexpected movement, it is extremely hazardous and may cause serious safety problems.
- If the Manipulator moves abnormally during operation of the robot system, immediately press the emergency stop switch. Continuing the abnormal operation is extremely hazardous and may result in serious injury to operators and/or severe equipment damage.
- The interlocks of the safeguards must be functioning when performing work. Performing work in a state where the switch does not turn ON or OFF, such as if it is covered with tape (in a state where the switch is disabled), is extremely hazardous because the safety function of the safeguard will not be activated. This may cause serious safety problems.

- If a person is pinched or trapped by the Manipulator due to malfunction or abnormality, use the brake release function to move the Manipulator and escape.
 - SCARA robot

Move joints without electromagnetic brakes directly by hand. For joints with brakes (Joints #3 and #4), press the brake release switch on the Manipulator and move the Manipulator by hand for the Controller main power supply.
- Do not move the Manipulator while the movable platform (linear axis, movable cart, AGV, etc.) is in motion. When in use, the Manipulator must always be surrounded by a safety fence. Operating the Manipulator while the movable platform is in motion may result in serious injury and/or severe damage to the robot system.
- Do not touch the Manipulator or Controller while they are in operation. When operating, the Manipulator and Controller may be hot and may cause burns.

WARNING

- Do not open the cover of the Controller or Manipulator except during maintenance. There is a high-voltage charging section inside, and there is a risk of electric shock even when the power is turned off.
- Do not touch or operate the Controller with wet hands. Touching or operating the product with wet hands may cause electric shock or malfunction.

CAUTION

- SCARA robot
 - Joints #1, #2, and #4:

If the Manipulator is operated repeatedly with an operating angle of 5° or less, the bearings used in the joints are likely to cause oil film shortage. Repeated operation may cause premature damage. To

prevent premature damage, operate the Manipulator to move each joint to an angle of 50° or more about once per hour.

- Joint #3:

If the up-and-down motion of the hand is 10 mm or less, move the hand about half or more of its maximum stroke about once per hour.

- Depending on the combination of the Manipulator motion speed, arm orientation, and hand load, vibration (resonance) may occur continuously throughout operation. Vibration occurs due to the natural vibration frequency of the arm and can be reduced by taking the following measures:
 - Changing the speed of the Manipulator
 - Changing the teach points
 - Changing the hand load
- If installing the Manipulator on a movable platform, stop the Manipulator when the movable platform is moving or operating. The Manipulator can be stopped by setting the motors of all axes to off (non-energized state). If a motor cannot be turned off, set the power mode to Low and ensure that the movable platform and Manipulator are exclusive and do not move at the same time.
- Immediately after operation is stopped, the Manipulator may be hot due to heat generated by the motor. Do not touch the Manipulator until the temperature has dropped. Operations such as teaching and maintenance should be performed only after the Manipulator temperature has dropped and it does not feel hot to the touch.
- If there is a brake release unit and external short connector
Operating the Manipulator without a brake release unit or external short connector connected may cause the brake to fail to release, possibly damaging the brake.
After using the brake release unit, be sure to connect the external short circuit connector to the Manipulator or make sure to leave the connector for the brake release unit connected.

3.6 Precautions for Maintenance

Before performing inspections or part replacements, please read this "Precautions for Maintenance" section carefully and make sure you understand safe procedures.

Robot system maintenance should be performed by people who have received maintenance training provided by Epson and the suppliers.

WARNING

- Do not disassemble the product in areas not described in the service manual or perform maintenance in a manner different from these procedures. Improper disassembly or maintenance may not only lead to a malfunction in the robot system, but can also cause serious safety issues.
- Persons who have not undergone training must never approach a Manipulator that is turned on. Also, do not enter the work envelope. If the Manipulator is turned on, it may make unexpected movements even if it appears to be stopped, which may result in serious safety problems. Also, safe work procedures should be established and followed to prevent hazards due to unexpected movement of the Manipulator or operator mishandling of the Manipulator.
- When checking the Manipulator's operation after replacing parts, be sure to step outside of the safety barriers. A Manipulator that has not been tested may move unexpectedly, which may cause serious safety problems.
- Before beginning full operation, make sure that the emergency stop switch and interlocked guard switch operate. Operation without the switches functioning properly may result in the safety functions failing to operate during an emergency, which is extremely hazardous and may result in serious injury and/or severe damage to the robot system.
- When touching the exterior terminals or connection connectors of the Controller for Controller inspection or the like, turn off the Controller and shut off the power supply to prevent electric shock.

- Shut off the supply power before performing cleaning or retightening terminal screws. Failure to shut off the supply power may cause electric shock, product damage, and malfunctions.

WARNING

- Remove the power plug before maintenance.

If necessary, perform lockout for safety. For details, refer to the following manual.

"Controller Manual"

- Before performing any replacement work, be sure to display that work is in progress, turn off the power for the robot system and related equipment, and disconnect the power plug. Performing any work procedure with the power turned on is extremely dangerous and may result in electric shock and/or malfunction of the robot system.
- Do not connect or disconnect the motor connector while the power is turned on. There is a risk the Manipulator may malfunction, which is extremely hazardous. Also, performing any work procedure with the power turned on may result in electric shock and/or malfunction of the robot system.
- Use cables with securely protected high-voltage sections and connect them securely. Also, do not put heavy objects on the cables, bend them severely, pull them forcibly, or pinch them. Damaged cables, broken wires, or contact failure is extremely hazardous and may result in electric shock and/or malfunction of the robot system.

CAUTION

- When using alcohol, liquid gaskets, or adhesives, carefully read the precautions for those products and thoroughly ensure safety. Also, pay

attention to the following points. Failure to be cautious may result in fire or safety problems.

- Do not handle near fire.
 - Use with good ventilation.
 - Wear protective equipment (such as goggles, oil-resistant gloves, and a mask).
 - If it adheres to the skin, rinse with water and soap.
 - If it enters the eyes or mouth, rinse thoroughly with clean water and seek medical attention.
- When applying grease, wear protective equipment (such as goggles, oil-resistant gloves, and a mask) and ensure safety when performing work. If grease enters the eyes or mouth or adheres to the skin, take the following measures:
- If it enters the eyes
After rinsing the eyes thoroughly with clean water, seek medical attention.
 - If it enters the mouth
If swallowed, do not force vomiting, and seek medical attention. If the mouth is contaminated, rinse thoroughly with water.
 - If adhered to skin
Rinse with water and soap.
- Immediately after operation is stopped, the Manipulator may be hot due to heat generated by the motor. Do not touch the Manipulator until the temperature has dropped. Operations such as teaching and maintenance should be performed only after the Manipulator temperature has dropped and it does not feel hot to the touch.
- During maintenance work on the Manipulator, ensure about 50 cm of free space around the Manipulator.
- When cleaning the Manipulator, do not rub it strongly with alcohol or benzene. Coated surfaces may lose their luster.

3.7 Controller Labels

Warning labels and labels are attached to the Controller and Manipulator.

Specific hazards exist in the vicinity of these labeled locations. Be thoroughly careful in handling.

To safely operate and maintain the robot system, be sure to observe the cautions and warnings described in the warning labels. Also, do not tear, damage, or remove these labels.

3.7.1 Warning Labels

A

	警告 警告 警告	内部危険部位。开机过程中或关机后5分钟内请勿打开机盖。 内部危険電壓。開機過程中或關機後5分鐘內請勿打開機蓋。	維修設備之前鎖定和掛牌電源 維修設備之前斷電和標識電源	該控制櫃沒有防塵、防滴濺或防爆結構。為了減少火災或電擊的危險，請安裝在污染程度為2級的環境中。 控制櫃沒有防塵、防水或防爆結構。為降低火災或觸電風險，請安裝在污染等級為2的環境中。
WARNING	HAZARDOUS VOLTAGE INSIDE. DO NOT OPEN THE COVER DURING POWER ON OR FOR 5 MINUTES AFTER POWER OFF.	LOCKOUT AND TAGOUT POWER BEFORE SERVICING EQUIPMENT	THE CONTROLLER DOES NOT HAVE A DUST-PROOF, Drip-PROOF OR EXPLOSION-PROOF CONSTRUCTION. TO REDUCE THE RISK OF FIRE OR ELECTRIC SHOCK, INSTALL IN A POLLUTION DEGREE 2 ENVIRONMENT.	
AVERTISSEMENT	TENSION INTERNE DANGEREUSE. NE PAS OUVRIE LE CAPOT PENDANT LA MISE SOUS TENSION OU JUSQU'A 5 MINUTES APRES LA MISE HORS TENSION.	VERROUILLER ET APOSER UNE PANCARTE SUR L'ALIMENTATION AVANT TOUTE INTERVENTION DE MAINTENANCE.	LE CONTRÔLEUR N'EST PAS ÉTANCHE À LA POUSSIERE, AUX GOUTTES D'EAU OU À L'EXPLOSION.POUR REDUIRE LE RISQUE D'INCENDIE OU DE CHOC ÉLECTRIQUE, INSTALLEZ-LE DANS UN ENVIRONNEMENT AVEC UN DEGRÉ DE POLLUTION 2.	
ADVERTENCIA	VOLTAJE PELIGROSO EN EL INTERIOR.NO ABRA LA CUBIERTA DURANTE EL ENCENDIDO O 5 MINUTOS DESPUES DEL APAGADO.	BLOQUEO Y ETIQUETADO DE ALIMENTACION ANTES DE DAR SERVICIO AL EQUIPO	EL CONTROLADOR NO TIENE UNA CONSTRUCCION APRUEBA DE POLVO, GOTEIO O EXPLOSION.	
ATENÇÃO	TENSÃO PERIGOSA INTERNAMENTE NÃO ABRA A TAMPÃO APOS LIGAR OU 5 MINUTOS APOS O DESLIGAMENTO.	BOLQUEAR A ENERGIA ANTES DA MANUTENÇÃO DO EQUIPAMENTO	O CONTROLADOR NÃO É À PROVA DE POEIRA, À PROVA DE GOTEJAMENTO, OU À PROVA DE EXPLOSAO.PARA REDUZIR O RISCO DE INCENDIO OU CHOQUE ELECTRICO, INSTALAR NUM AMBIENTE COM UM GRAU DE POLUICAO 2.	
ОСТОРОЖНО	ОПАСНОЕ НАПРЯЖЕНИЕ ВНУТРИ. НЕ ОТКРЫВАЙТЕ КРЫШКУ ВО ВРЕМЯ ВКЛЮЧЕНИЯ ПИТАНИЯ ИЛИ В течение 5 МИНУТ ПОСЛЕ ВЫКЛЮЧЕНИЯ ПИТАНИЯ.	БЛОКИРОВКА И ПИТАНИЕ ПЕРЕД ОБСЛУЖИВАНИЕМ ОБОРУДОВАНИЯ	КОНТРОЛЛЕР НЕ ИМЕЕТ ПЫЛЕПРОНИЦАЕМОЙ, КАПЛЕЗАЩИЩЕННОЙ ИЛИ ВЗРЫВООЗАЩИЩЕННОЙ КОНСТРУКЦИИ,ЧТОБЫ СНИЗИТЬ РИСК ВОЗГОРАНИЯ ИЛИ ПОРАЖЕНИЯ ЭЛЕКТРИЧЕСКИМ ТОКОМ, УСТАНАВЛИВАЙТЕ КОНТРОЛЛЕР В СРЕДЕ СО СТЕПЕНЬЮ ЗАГРЯЗНЕНИЯ 2.	
경고	내부의 위험한 전압 전원을 켜거나 꺼진 후 5분 후에는 5분 동안 차폐를 유지하십시오.	기기를 정비하기 전에 전원을 차단해 주십시오.	컨트롤러는 방진, 방적, 방폭 구조가 아닙니다. 화재나 감전의 위험을 줄이려면 "오염도 2(사무실 같은 환경)"에 설치하십시오.	
警告	内部に感電の危険。電源を入れている間、または電源を切ってから5分間は、カバーを開けないでください。	機器をメンテナンスする前のロックアウト、およびタグアウト	コントローラーは、防塵・防滴・防爆構造になっていません。火災や感電の危険を減らすために、汚染度2の環境に設置してください。	
300s				

Touching any internal electrified parts while the power is turned on may cause electric shock.

Do not open the cover for 300 seconds after turning off the power. Residual voltage may cause electric shock.

Turn off the POWER switch and perform lockout / tag-out before starting maintenance or repair.

B

Do not connect the following devices to the TP port. The different signal arrangement could cause a breakdown in the device.

- Dummy plug (optional device)
- Operation Pendant OP500
- Operator Pendant OP500RC
- Jog Pad JP500
- Teaching Pendant TP-3**
- Operator Panel OP1
- Teach Pendant TP1
- Teach Pendant TP3

3.7.2 Labels

1

Battery:
CR2032

This label indicates the battery type. It is applied to the device interior.

2

This indicates the product name, model name, serial number, information of supported laws and regulations, product specifications (Rated, Full load Current, SCCR, Weight, Largest Motor Rating), Main document No., manufacturer, importer, date of manufacture, country of manufacture, and the like.

For details, see the label affixed to the product.

3.7.3 Labelled Locations

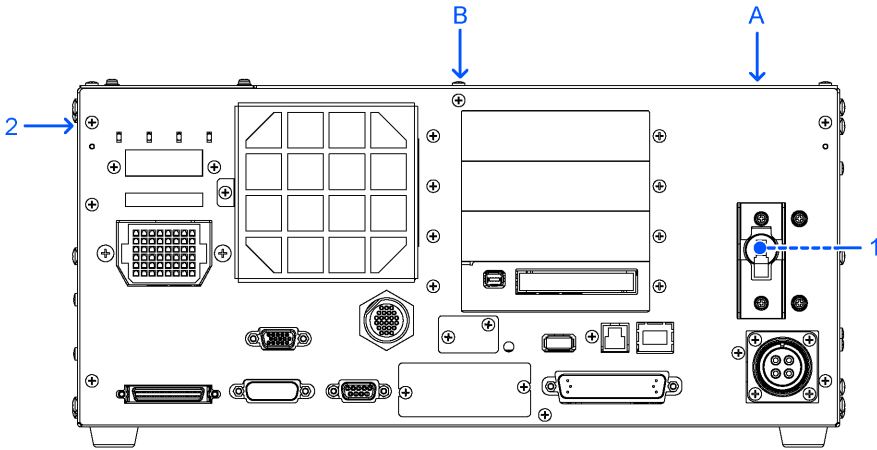

3.8 Manipulator Labels

Warning labels and labels are attached to the Controller and Manipulator. Specific hazards exist in the vicinity of these labeled locations. Be thoroughly careful in handling.

To safely operate and maintain the robot system, be sure to observe the cautions and warnings described in the warning labels. Also, do not tear, damage, or remove these labels.

3.8.1 Warning Labels

A



Touching any internal electrified parts while the power is turned on may cause electric shock.

Also, regarding the GX4 ESD specifications and Cleanroom & ESD specifications, if the cables inside the Manipulator wear down over a long period of operation and cause an internal short circuit, the conduit tube may be electrified. Touching the conduit tube while the power is turned on may cause electric shock.

B1, B2

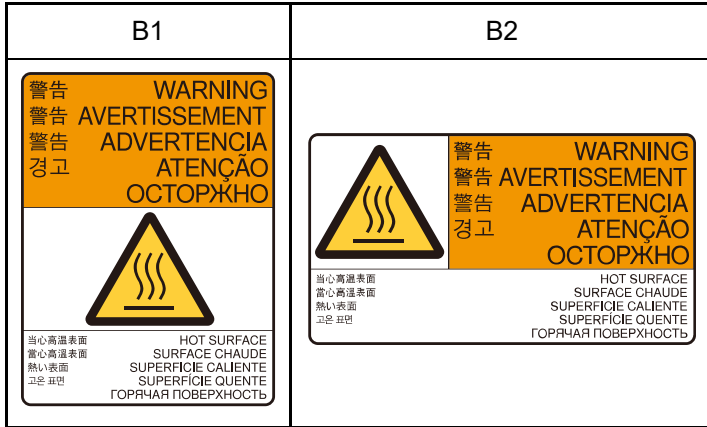

The surface of the Manipulator is hot during and after operation, and there is a risk of burns.

3.8.2 Labels

1

This indicates the product name, model name, serial number, information of supported laws and regulations, product specifications (Weight, MAX. REACH, MAX. PAYLOAD, AIR PRESSURE, Motor Power), Main document No., manufacturer, importer, date of manufacture, country of manufacture, and the like.

For details, see the label affixed to the product.

2



Indicates the position of a brake release button.

3



Indicates the position of a threaded hole for an eyebolt mounting screw.

3.8.3 Labelled Locations

3.8.3.1 GX-C Series

3.8.3.1.1 GX4-C

Common (Arm #2)

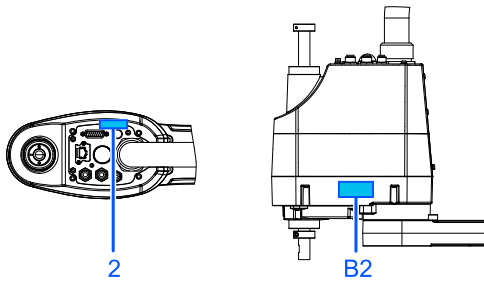

Table top mounting specifications

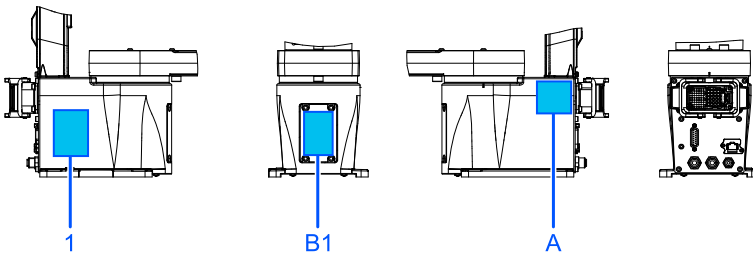
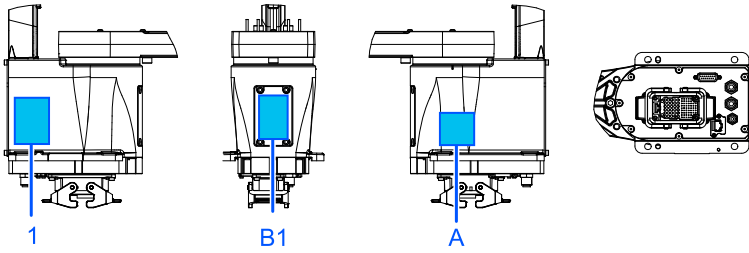
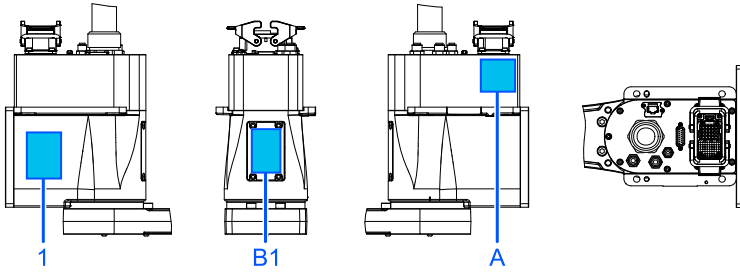

Table top mounting specifications (cable routing from bottom side)



Multiple mounting specifications



3.8.3.1.2 GX8-C

Common (Arm #2)

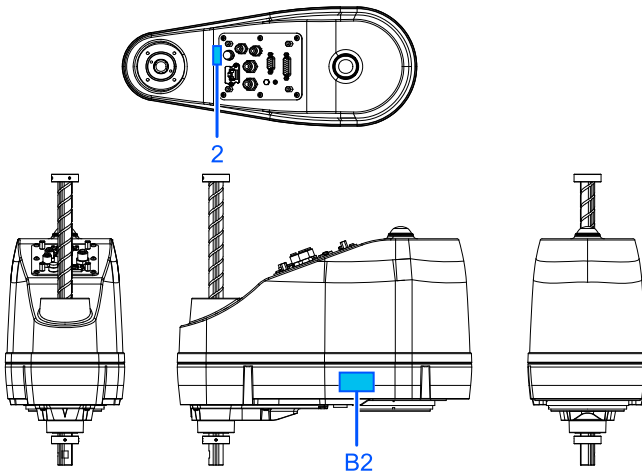

Table top mounting specifications

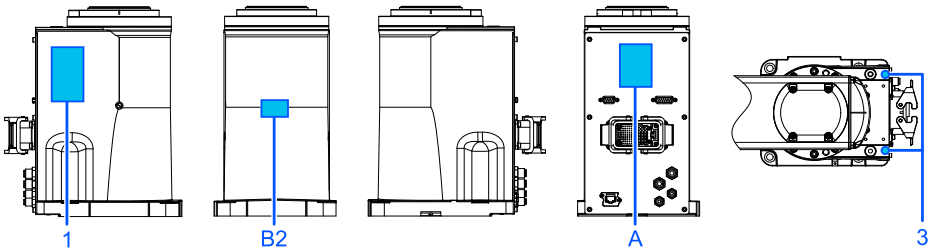
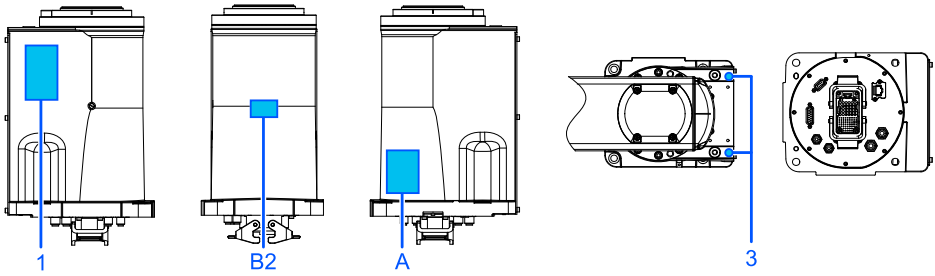
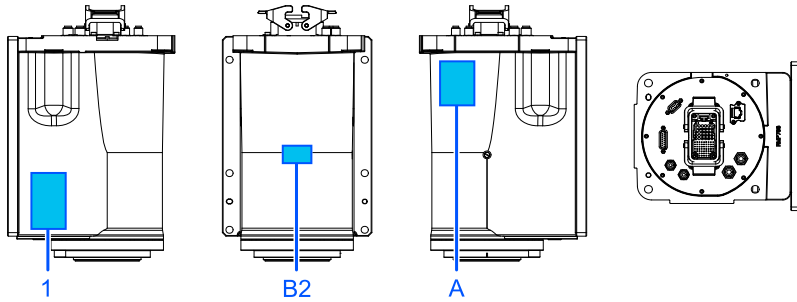

Table top mounting specifications (cable routing from bottom side)



Wall mounting specifications



Ceiling mounting specifications

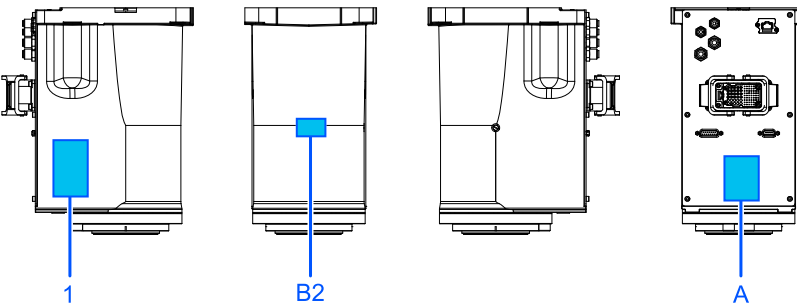

3.8.3.1.3 GX10-C/GX20-C

Common for all models

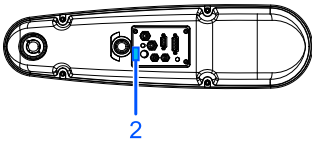
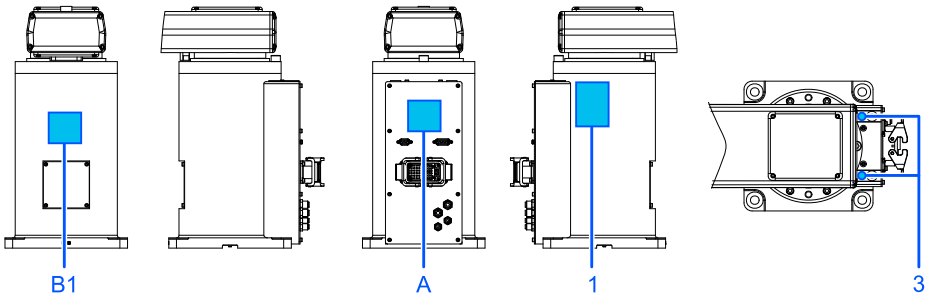
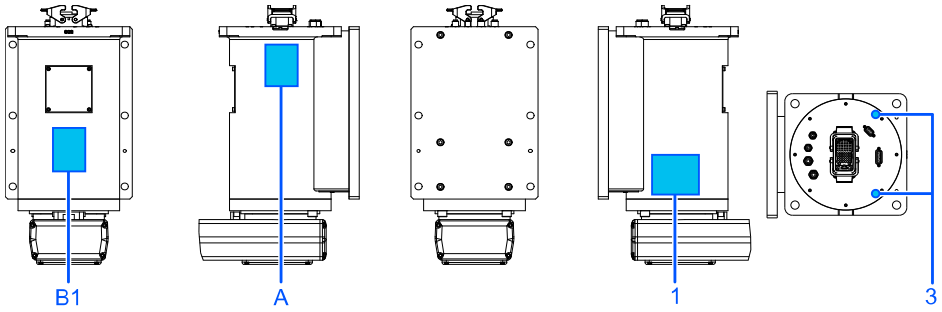

Table top mounting specifications



Wall mounting specifications



Ceiling mounting specifications

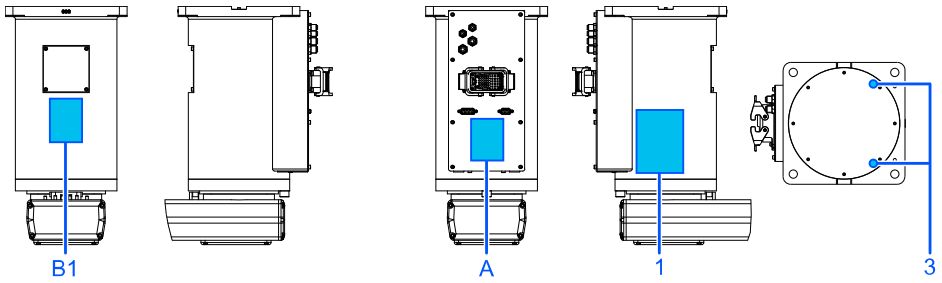

3.9 Safety Functions

The robot system has the following safety functions. Because of their particular importance for safety, always make sure that they are working before using the robot system.

Controller Safety Function standard functions:

▪ **Safe Torque OFF (STO)**

A signal input from the Robot Controller opens a relay to cut off the power supply to the motors and stop the robot. This is a safe state for the Robot Controller. STO is operated indirectly from an emergency stop or protective stop. It cannot operate directly.

▪ **Emergency Stop**

This function allows the robot to perform an emergency stop by a signal input from a safety relay or from an emergency stop switch attached to the emergency stop input connector or safety I/O connector. After the signal is input, an SS1 is executed, and after the motor stops, the robot is in an emergency stop status. During the emergency stop status, EP is displayed on the 7-segment LED of the Robot Controller.

There are three emergency stop circuits for the Robot Controller:

- Emergency stop input connector (E-Stop)
- Port of the safety I/O connector configured for the emergency stop (Safety Input)
- Emergency stop switch attached to Teach Pendant (E-Stop, TP)

▪ **Safeguard (SG) (protective stop)**

This function allows the robot to perform a protective stop by a signal input from a safety peripheral device attached to the safety I/O connector. After the signal is input, the SS1 is executed, and after the motor stops, the robot is in a protective stop status. SO is displayed on the 7-segment LED of the Robot Controller.

The Robot Controller safeguard (SG) circuit is as follows.

- Port of the safety I/O connector configured for the safeguard (SG)

■ **Enable**

Enable is the path connected to the enable switch when the Teach Pendant is connected. Only Epson Teach Pendants can be connected, and customer enable switches cannot be connected.

When the system detects that the enable switch of the Teach Pendant is not in the middle position, the SS1 is executed, and the robot is in an STO state.

■ **Soft Axis Limiting**

This monitors that each axis of the robot is within its operating range. If the system detects that an axis of the robot exceeded the limiting range, the robot emergency stop and STO are immediately executed, putting the Robot Controller in the emergency stop status.

The restricted range for each axis of the robot is set in the dedicated software (Safety Function Manager).

■ **Safety outputs**

External safety devices can be connected to the safety outputs of the Robot Controller to perform notifications of the ON/OFF status of the safety functions. By assigning settings in the dedicated software (Safety Function Manager), the following safety signals can be output:

- STO state
- Status of the emergency stop switch
- Status of the enable switch
- Enabled/disabled status of the Safety Limited Speed (SLS)
- Enabled/disabled status of the Safety Limited Position (SLP)

Controller Safety Function charged optional functions:

■ **Safety Limited Speed (SLS)**

This monitors the operating speed of the robot. If the system detects that the robot exceeded the Maximum Speed, the robot emergency stop and STO are immediately executed, putting the Robot Controller in the emergency stop status.

The safety speed limit of the robot is set in the dedicated software (Safety Function Manager).



KEY POINTS

The speed monitoring function during teaching can be used as a standard function.

- **Safety Limited Position (SLP)**

This monitors the robot's position and joint angles. If the system detects that the robot exceeded the monitored areas or joint angle limit, the robot emergency stop and STO are immediately executed, putting the Robot Controller in the emergency stop status.

The Monitored Areas and Joint Angle Limit of the robot are set in the dedicated software (Safety Function Manager).

3.10 Protective Functions

The robot system is equipped with protective functions to protect peripheral devices and the robot system itself. However, these functions are only intended for unexpected events.

Low power mode

This mode keeps a low motor output.

Execution of a power mode change command allows changing to a restricted state (low power mode) regardless of whether the safeguard is opened or closed and regardless of the operation mode. Low power mode ensures operator safety and reduces the risk of destruction and damage to peripheral equipment due to careless operation.

Dynamic braking

The dynamic brake circuit consists of a relay that short-circuits the motor power wire at the motor side (brake action). When an emergency stop is input, or when the following abnormalities are detected, the dynamic brake is activated to stop motor rotation. (Encoder disconnection detection, overload detection, torque error detection, speed error detection, position deviation overflow detection, speed deviation overflow detection, CPU error detection, memory error detection, overheat detection)

Overload detection

This detects a motor overload state.

Torque error detection

This detects abnormalities in the motor torque.

Speed error detection

This detects abnormalities in the motor speed.

Position deviation overflow detection

This detects abnormalities in the difference between the motion command and the current position.

Speed deviation overflow detection

This detects abnormalities in the difference between the speed command and actual speed.

CPU error detection

A watchdog timer is used to detect abnormalities in the CPU that controls the motor. Also, the CPU that manages the system in the Controller and the CPU that controls the motor constantly monitor each other's status.

Memory error detection

This detects checksum errors in memory.

Overheat detection

This detects temperature abnormalities in the motor driver module.

Relay melting detection

This detects melting or open failure of relay contacts.

Overvoltage detection

This detects overvoltage errors in the Controller.

Power supply voltage drop detection

This detects a drop in the power supply voltage.

Temperature error detection

This detects abnormalities in the Controller temperature.

Fan error detection

This detects abnormalities in the fan speed.

4. Role and Training for Safety Managers

4.1 Role for Safety Managers

Safety managers should perform the following:

- Password management
- Training implementation

4.1.1 Password management

Safety managers should manage the following passwords:

- Epson RC+ security user password
- Safety function password
- Controller Ethernet connection password

4.1.2 Training implementation

Safety managers should ensure that personnel responsible for programming, operating, and maintaining the Manipulator and robot system undergo proper training. Also, they should make sure that personnel have the ability to safely perform that work.

Training should include at least the following items:

- Description of standard safety procedures and safety recommendations by robot manufacturers and robot system designers
- Description of the response to an emergency or abnormal situation (e.g., means of escape if caught in a Manipulator)
- Clear description of the work
- Description of all control devices required for the work and their functions
- Description of hazards associated with the work
- Specific methods to avoid foreseeable hazards, including safe work procedures
- Description of the method for testing the functions of safety devices and interlocks or description of the method to check that they are functioning properly
- Description of the method for checking safety function parameters and of the method for setting safety function parameters correctly

4.2 Knowledge and Training Required to Work with Robot Systems

User definition	Work description	Required qualifications and training
Operator	Work with robot systems	Persons who have attended "Safety Training"*1
	Daily/periodic inspections (work that does not require disassembly)	
Installers /Instructors	Installation work*4	- Persons who have attended "Safety Training"*1, and
	Teaching	- Who have attended "Introduction Training"*2
Service Engineers	Repair	- Persons who have attended "Safety Training"*1, and
	Overhaul	- Who have attended
	Installation of optional circuit boards on Controllers	"Maintenance Training"*3

*1 "Safety Training" refers to "safety training for workers engaged in work related to industrial robots" as required by the laws and regulations of the respective country. The safety training for workers engaged in work related to industrial robots must include the following content.

- Knowledge of industrial robots
- Knowledge of industrial robot operation, teaching, etc.
- Knowledge of inspection and other work
- Education on relevant laws and regulations

*2 "Introduction Training" refers to training provided by Epson and the supplier.

*3 "Maintenance Training" refers to training provided by Epson and the supplier.

*4 The transportation of materials using cranes and forklifts, and power plug

installation (e.g., when installing a power plug to match a factory power socket) must be performed by persons with the necessary qualifications and skills.

5. Manuals for This Product

5.1 Manual Types

This describes the typical types of manuals for this product and presents an overview of their content.

■ **Safety Manual (booklet, PDF manual)**

This manual contains safety-related information intended for all people who use this product. It also guides the user through the process from unpacking to usage and the manuals that should be referred to next.

Please read this manual first.

- Safety information and residual risks of robot systems
- Declaration of Conformity
- Training
- Process from unpacking to usage

■ **Robot Controller Safety Function Manual (PDF manual)**

This describes the procedures for configuring the safety functions of this product and the configuration software. It is primarily intended for those who design robot systems.

■ **RC800-A Manual (PDF manual)**

This manual describes the installation of the entire robot system and explains the specifications and functions of the Controller. It is primarily intended for those who design robot systems.

- Robot system installation procedure (specific details on the process from unpacking to usage)
- Controller daily inspection points
- Controller specifications and basic functions

■ **xx Series Manual (PDF manual)** (xx: Manipulator series name)

This manual describes the specifications and functions of the Manipulator. It is primarily intended for those who design robot systems.

- Manipulator installation, technical information needed for design, function and specification tables, etc.

- Manipulator daily inspection points
- **Status Code/Error Code List (PDF manual)**
This provides the code numbers displayed on the Controller and messages displayed in the message area of the software. It is primarily intended for those who design and program robot systems.
- **Epson RC+ User's Guide (PDF manual)**
This manual presents an overview of the program development software.
- **Epson RC+ SPEL+ Language Reference (PDF manual)**
This manual explains the robot programming language SPEL+.
- **Other manuals (PDF manuals)**
Manuals are available for each option.

Manuals for maintenance are not included with the product. Maintenance should be performed by people who have received maintenance training provided by Epson and the suppliers. For more information, please contact the supplier.

5.2 Viewing Manuals

PDF manuals can be viewed from the Epson RC+ software and the desktop.

Epson RC+ 8.0:

Select Epson RC+ 8.0 menu - [Help] - [Manual]. Click [Start] - [Program] - [Epson RC+ 8.0] - [Epson Robot Manuals] from the desktop.

Double click [Epson Robot Manuals] icon on the desktop.

You can also view them from the following website:

URL: <https://download.epson.biz/robots/>

5.3 Installing the Software and Manuals

First, make sure your PC is connected to the Internet.

1. Insert the software disc which provided with the product into the PC. Execute `EpsonRobotSoftwareInstallerSetup.exe` in the disc and follow the instructions on the screen to start installation.



KEY POINTS

- For the Epson Robot Software Installer installation, refer to the Epson Robot Software Installer manual which is directly under the disc.
- If you get the Epson RC+ setup file from the Internet, the latest software and manuals installation are available.

2. When the option selection appears, make sure that there is a check mark next to the manuals before proceeding.



KEY POINTS

- Installation takes several minutes.
- The manuals are available in PDF format. To view the manuals, use the PDF viewer included with Windows. You can also install Adobe Acrobat Reader or other PDF viewer.

3. When the completion screen appears, installation is complete.



KEY POINTS

If a message prompting you to restart appears, restart your PC.

6. Process from Unpacking to Disposal

6.1 Handling from Unpacking to Disposal

Device lifecycle	Work outline	
1. Unpacking, transporting 2. Installing, connecting	Unpack the products* and transport them to the installation location Install the products* and connect the wires	
3. Teaching, programming	-	Turn on the Controller and check initial operation
	First Step	<ul style="list-style-type: none"> - Perform initial setup of Epson RC+ - Checking Safety Function Parameters - Perform initial setup of the safety function parameters (only for customers who want to edit the safety functions) - Check the operation of the safety devices (emergency stop switch, safeguard) - Move the Manipulator to the initial position
	Second Step	Connect the external equipment (peripherals)
	-	<ul style="list-style-type: none"> - Teach the Manipulator - Create a SPEL program
4. Test operation 5. Automatic operation	Perform program test operation Run the program and operate automatically	
6. Maintenance	<ul style="list-style-type: none"> - Perform daily inspection of the products* - Perform regular inspection of the products* - Overhaul the products* (replace parts) 	
7. Storage, disposal 8. Troubleshooting	Store the products*, dispose of the products* Support for products* trouble and errors	

*: Manipulator and Controller

For more details, refer to the manual for the product you are using.

For details about how to view manuals, refer to the following section.

"Manuals for This Product (p.61) "



KEY POINTS

When an error occurs, be careful of the following:

- Error numbers displayed on the Controller or Teach Pendant provide clues about the cause of the abnormality. When an error occurs, be sure to write down the error number and refer to the following manual to take corrective measures.
"Status Code/Error Code List"
- If the abnormality is caused solely by Epson robot system and is beyond the scope of customer's capability, please contact our service department (the supplier).

7. Appendix

7.1 Appendix: China RoHS

This table and the environmental protection expiration date labels on the product are based on the laws and regulations in mainland China, and are not applicable outside of mainland China.

产品中有害物质的名称及含量

机器人型号名称	GX-C 系列					
部件名称	有害物质					
	铅	汞	镉	六价铬	多溴联苯	多溴二苯醚
	(Pb)	(Hg)	(Cd)	(Cr(VI))	(PBB)	(PBDE)
机械手臂	×	○	○	○	○	○
电机(执行器单元、电机单元)	×	○	○	○	○	○
减速机单元	×	○	○	○	○	○
电磁制动器	×	○	○	○	○	○
同步皮带	○	○	○	○	○	○
电池单元 (电池、电池固定架、电池板)	×	○	○	○	○	○
密封(密封垫圈、油封、润滑脂封、垫片、O型环)	×	○	○	○	○	○
润滑脂	○	○	○	○	○	○
电缆(M/C电缆、连接电缆)	×	○	○	○	○	○
散热片	○	○	○	○	○	○
LED指示灯	○	○	○	○	○	○
电路板	×	○	○	○	○	○
外罩	○	○	○	○	○	○
滚珠丝杠花键	○	○	○	○	○	○
制动解除开关	×	○	○	○	○	○
波纹管	×	○	○	○	○	○
FPC单元	×	○	○	○	○	○
扎带	○	○	○	○	○	○
原点标记	○	○	○	○	○	○
气管接头	×	○	○	○	○	○
<p>本表格依据SJ/T 11364的规定编制。</p> <p>○：表示该有害物质在该部件所有均质材料中的含量在GB/T 26572规定的限量要求以下。</p> <p>×：表示该有害物质至少在该部件的某一均质材料中的含量超出GB/T 26572规定的限量要求。</p> <p>本产品中含有的有害物质的部件皆因全球技术发展水平限制而无法实现有害物质的替代。</p>						
<p>产品环保使用期限的使用条件</p> <p>关于适用于在中华人民共和国境内销售的本产品的环保使用期限，在遵守该产品的安全及使用注意事项的条件下，从生产日期开始计算，在标志的年限内，本产品中含有的有害物质不会对环境造成严重污染或对人身、财产造成严重损害。</p> <p>附注：本表格及环保使用期限标志依据中国大陆地区的有关规定而制定，中国大陆地区以外的国家/地区则无需关注。</p> <p>Note: This sheet and Environment Friendly Use Period label on the product are based on the laws and regulations in Chinese mainland. These are not applicable outside of Chinese mainland.</p>						

产品中有害物质的名称及含量

机器人型号名称		GX-C 系列					
部件名称		有害物质					
		铅	汞	镉	六价铬	多溴联苯	多溴二苯醚
		(Pb)	(Hg)	(Cd)	(Cr(VI))	(PBB)	(PBDE)
选件	MC短接连接器	×	○	○	○	○	○
	制动解除单元	×	○	○	○	○	○
	相机安装板	×	○	○	○	○	○
	托架	×	○	○	○	○	○
	壁挂式选件	×	○	○	○	○	○
	外部接线单元	×	○	○	○	○	○
	工具适配器 (支架)	×	○	○	○	○	○
	耦合器	×	○	○	○	○	○
	机械挡块	×	○	○	○	○	○
	法兰	×	○	○	○	○	○
	波纹管	×	○	○	○	○	○
	底座适配器	×	○	○	○	○	○
	底座侧固定支架	×	○	○	○	○	○
	用户接头套件	×	○	○	○	○	○
	用户连接器套件	×	○	○	○	○	○
S250 series (力传感器)	×	○	○	○	○	○	
<p>本表格依据SJ/T 11364的规定编制。</p> <p>○：表示该有害物质在该部件所有均质材料中的含量在GB/T 26572规定的限量要求以下。</p> <p>×：表示该有害物质至少在该部件的某一均质材料中的含量超出GB/T 26572规定的限量要求。</p> <p>本产品中含有的有害物质的部件皆因全球技术发展水平限制而无法实现有害物质的替代。</p>							
<p>产品环保使用期限的使用条件</p> <p>关于适用于在中华人民共和国境内销售的本产品的环保使用期限，在遵守该产品的安全及使用注意事项的条件下，从生产日期开始计算，在标志的年限内，本产品中含有的有害物质不会对环境造成严重污染或对人身、财产造成严重损害。</p> <p>附注：本表格及环保使用期限标志依据中国大陆地区的有关规定而制定，中国大陆地区以外的国家/地区则无需关注。</p> <p>Note: This sheet and Environment Friendly Use Period label on the product are based on the laws and regulations in Chinese mainland. These are not applicable outside of Chinese mainland.</p>							

产品中有害物质的名称及含量

控制器型号名称		RC800-A					
部件名称		有害物质					
		铅	汞	镉	六价铬	多溴联苯	多溴二苯醚
		(Pb)	(Hg)	(Cd)	(Cr(VI))	(PBB)	(PBDE)
控制器		×	○	○	○	○	○
机壳		○	○	○	○	○	○
电路板		×	○	○	○	○	○
开关电源		×	○	○	○	○	○
风扇		×	○	○	○	○	○
线束		×	○	○	○	○	○
电源保护装置		×	○	○	○	○	○
存储卡		×	○	○	○	○	○
电池		○	○	○	○	○	○
连接器附件		×	○	○	○	○	○
<p>本表格依据SJ/T 11364的规定编制。</p> <p>○：表示该有害物质在该部件所有均质材料中的含量在GB/T 26572规定的限量要求以下。</p> <p>×：表示该有害物质至少在该部件的某一均质材料中的含量超出GB/T 26572规定的限量要求。</p> <p>本产品中含有的有害物质的部件皆因全球技术发展水平限制而无法实现有害物质的替代。</p>							
<p>产品环保使用期限的使用条件</p> <p>关于适用于在中华人民共和国境内销售的本产品的环保使用期限，在遵守该产品的安全及使用注意事项的条件下，从生产日期开始计算，在标志的年限内，本产品中含有的有害物质不会对环境造成严重污染或对人身、财产造成严重损害。</p> <p>附注：本表格及环保使用期限标志依据中国大陆地区的有关规定而制定，中国大陆地区以外的国家/地区则无需关注。</p> <p>Note: This sheet and Environment Friendly Use Period label on the product are based on the laws and regulations in Chinese mainland. These are not applicable outside of Chinese mainland.</p>							

产品中有害物质的名称及含量

控制器型号名称		RC800-A					
部件名称		有害物质					
		铅 (Pb)	汞 (Hg)	镉 (Cd)	六价铬 (Cr(VI))	多溴联苯 (PBB)	多溴二苯醚 (PBDE)
选项	USB密钥	×	○	○	○	○	○
	电缆 (MC电缆、TP转换电缆、控制器转换电缆 等)	×	○	○	○	○	○
	Hot Plug Kit	×	○	○	○	○	○
	TP2	×	○	○	○	○	○
	TP4	×	○	○	○	○	○
	再生模块	×	○	○	○	○	○
	接线端子	×	○	○	○	○	○
	通信板卡	×	○	○	○	○	○
	底座安装金属板	×	○	○	○	○	○
	布线单元	×	○	○	○	○	○
	扩展 I / O 套件 (电路板/电缆)	×	○	○	○	○	○
	紧急停止开关	×	○	○	○	○	○
	I/O连接器	×	○	○	○	○	○
	传送带跟踪套件 (控制器/电缆)	×	○	○	○	○	○
	选项模块 (面板/操作模块/电缆)	×	○	○	○	○	○
	脉冲发生套件 (控制器/连接器)	×	○	○	○	○	○
	Gi gE相机	×	○	○	○	○	○
	相机镜头 (HF Series)	×	○	○	○	○	○
	AC适配器	×	○	○	○	○	○
	分光相机	×	○	○	○	○	○
	USB相机	×	○	○	○	○	○
	相机延长管	×	○	○	○	○	○
	相机三脚架适配器	×	○	○	○	○	○
	CV2	×	○	○	○	○	○
	CV2-B	×	○	○	○	○	○
	Gi gE相机触发连接器	×	○	○	○	○	○
VRT (减振装置)	×	○	○	○	○	○	
<p>本表格依据SJ/T 11364的规定编制。</p> <p>○：表示该有害物质在该部件所有均质材料中的含量在GB/T 26572规定的限量要求以下。</p> <p>×：表示该有害物质至少在该部件的某一均质材料中的含量超出GB/T 26572规定的限量要求。</p> <p>本产品中含有的有害物质的部件皆因全球技术发展水平限制而无法实现有害物质的替代。</p>							
<p>产品环保使用期限的使用条件</p> <p>关于适用于在中华人民共和国境内销售的本产品的环保使用期限，在遵守该产品的安全及使用注意事项的条件下，从生产日期开始计算，在标志的年限内，本产品中含有的有害物质不会对环境造成严重污染或对人身、财产造成严重损害。</p> <p>附注：本表格及环保使用期限标志依据中国大陆地区的有关规定而制定，中国大陆地区以外的国家/地区则无需关注。</p> <p>Note: This sheet and Environment Friendly Use Period label on the product are based on the laws and regulations in Chinese mainland. These are not applicable outside of Chinese mainland.</p>							